



Cyclone II Device Handbook, Volume 1



101 Innovation Drive
San Jose, CA 95134
(408) 544-7000
<http://www.altera.com>

Preliminary Information

Copyright © 2005 Altera Corporation. All rights reserved. Altera, The Programmable Solutions Company, the stylized Altera logo, specific device designations, and all other words and logos that are identified as trademarks and/or service marks are, unless noted otherwise, the trademarks and service marks of Altera Corporation in the U.S. and other countries. All other product or service names are the property of their respective holders. Altera products are protected under numerous U.S. and foreign patents and pending applications, maskwork rights, and copyrights. Altera warrants performance of its semiconductor products to current specifications in accordance with Altera's standard warranty, but reserves the right to make changes to any products and services at any time without notice. Altera assumes no responsibility or liability arising out of the application or use of any information, product, or service described herein except as expressly agreed to in writing by Altera Corporation. Altera customers are advised to obtain the latest version of device specifications before relying on any published information and before placing orders for products or services.



Printed on recycled paper



I.S. EN ISO 9001



About this Handbook

This handbook provides comprehensive information about the Altera® Cyclone II family of devices.

How to Contact Altera

For the most up-to-date information about Altera products, go to the Altera world-wide web site at www.altera.com. For technical support on this product, go to www.altera.com/mysupport. For additional information about Altera products, consult the sources shown below.

Information Type	USA & Canada	All Other Locations
Technical support	www.altera.com/mysupport/	altera.com/mysupport/
	(800) 800-EPLD (3753) (7:00 a.m. to 5:00 p.m. Pacific Time)	(408) 544-7000 (1) (7:00 a.m. to 5:00 p.m. Pacific Time)
Product literature	www.altera.com	www.altera.com
Altera literature services	literature@altera.com (1)	literature@altera.com (1)
Non-technical customer service	(800) 767-3753	Contact your local Altera sales office or sales representative.
FTP site	ftp.altera.com	ftp.altera.com





Note to table:

(1) You can also contact your local Altera sales office or sales representative.

Typographic Conventions

This document uses the typographic conventions shown below.

Visual Cue	Meaning
Bold Type with Initial Capital Letters	Command names, dialog box titles, checkbox options, and dialog box options are shown in bold, initial capital letters. Example: Save As dialog box.
bold type	External timing parameters, directory names, project names, disk drive names, filenames, filename extensions, and software utility names are shown in bold type. Examples: f_{MAX} , lqdesigns directory, d: drive, chiptrip.gdf file.
<i>Italic Type with Initial Capital Letters</i>	Document titles are shown in italic type with initial capital letters. Example: <i>AN 75: High-Speed Board Design</i> .

Visual Cue	Meaning
<i>Italic type</i>	<p>Internal timing parameters and variables are shown in italic type. Examples: t_{PIA}, $n + 1$.</p> <p>Variable names are enclosed in angle brackets (< >) and shown in italic type. Example: <file name>, <project name>.pdf file.</p>
Initial Capital Letters	Keyboard keys and menu names are shown with initial capital letters. Examples: Delete key, the Options menu.
“Subheading Title”	References to sections within a document and titles of on-line help topics are shown in quotation marks. Example: “Typographic Conventions.”
Courier type	<p>Signal and port names are shown in lowercase Courier type. Examples: data1, tdi, input. Active-low signals are denoted by suffix n, e.g., resetn.</p> <p>Anything that must be typed exactly as it appears is shown in Courier type. For example: c:\qdesigns\tutorial\chiptrip.gdf. Also, sections of an actual file, such as a Report File, references to parts of files (e.g., the AHDL keyword SUBDESIGN), as well as logic function names (e.g., TRI) are shown in Courier.</p>
1., 2., 3., and a., b., c., etc.	Numbered steps are used in a list of items when the sequence of the items is important, such as the steps listed in a procedure.
■ ● ●	Bullets are used in a list of items when the sequence of the items is not important.
✓	The checkmark indicates a procedure that consists of one step only.
	The hand points to information that requires special attention.
	The caution indicates required information that needs special consideration and understanding and should be read prior to starting or continuing with the procedure or process.
	The warning indicates information that should be read prior to starting or continuing the procedure or processes
↵	The angled arrow indicates you should press the Enter key.
	The feet direct you to more information on a particular topic.



About this Handbook	iii
How to Contact Altera	iii
Typographic Conventions	iii

Chapter Revision Dates	xiii
-------------------------------------	-------------

Section I. Cyclone II Device Family Data Sheet

Revision History	Section I-2
------------------------	-------------

Chapter 1. Introduction

Introduction	1-1
Features	1-1

Chapter 2. Cyclone II Architecture

Functional Description	2-1
Logic Elements	2-3
LE Operating Modes	2-4
Logic Array Blocks	2-7
LAB Interconnects	2-8
LAB Control Signals	2-8
MultiTrack Interconnect	2-10
Row Interconnects	2-10
Column Interconnects	2-12
Device Routing	2-15
Global Clock Network & Phase-Locked Loops	2-16
Dedicated Clock Pins	2-19
Dual-Purpose Clock Pins	2-20
Global Clock Network	2-20
Global Clock Network Distribution	2-22
PLLs	2-25
Embedded Memory	2-27
Memory Modes	2-30
Clock Modes	2-31
M4K Routing Interface	2-31
Embedded Multipliers	2-32
Multiplier Modes	2-35
Embedded Multiplier Routing Interface	2-35
I/O Structure & Features	2-37

External Memory Interfacing	2-44
Programmable Drive Strength	2-49
Open-Drain Output	2-51
Slew Rate Control	2-51
Bus Hold	2-51
Programmable Pull-Up Resistor	2-52
Advanced I/O Standard Support	2-52
High-Speed Differential Interfaces	2-54
Series On-Chip Termination	2-55
I/O Banks	2-57
MultiVolt I/O Interface	2-60

Chapter 3. Configuration & Testing

IEEE Std. 1149.1 (JTAG) Boundary Scan Support	3-1
SignalTap II Embedded Logic Analyzer	3-5
Configuration	3-6
Operating Modes	3-6
Configuration Schemes	3-7
Cyclone II Automated Single Event Upset Detection	3-7
Custom-Built Circuitry	3-8
Software Interface	3-8

Chapter 4. Hot Socketing, ESD & Power-On Reset

Introduction	4-1
Cyclone II Hot-Socketing Specifications	4-1
Devices Can Be Driven before Power-Up	4-2
I/O Pins Remain Tri-States during Power-Up	4-2
Signal Pins Do Not Have Internal Current Paths to V_{CCIO} or V_{CCINT} Power Supplies	4-2
Hot-Socketing Feature Implementation in Cyclone II Devices	4-3
ESD Protection	4-5
ESD Testing	4-5
ESD Circuitry	4-6
Power-On Reset Circuitry	4-8
Conclusion	4-9

Chapter 5. DC Characteristics & Timing Specifications

Operating Conditions	5-1
Single-Ended I/O Standards	5-4
Differential I/O Standards	5-7
DC Characteristics for Different Pin Types	5-10
Power Consumption	5-12
Timing Specifications	5-13
Preliminary & Final Timing Specifications	5-14
High Speed I/O Timing Specifications	5-16

Chapter 6. Reference & Ordering Information

Software	6-1
----------------	-----

Device Pin-Outs	6-1
Ordering Information	6-1

Section II. Clock Management

Revision History	Section II-1
------------------------	--------------

Chapter 7. PLLs in Cyclone II Devices

Introduction	7-1
Cyclone II PLL Hardware Overview	7-2
PLL Reference Clock Generation	7-6
Software Overview	7-6
Clock Feedback Modes	7-10
Normal Mode	7-10
Zero Delay Buffer Mode	7-11
No Compensation Mode	7-12
Hardware Features	7-13
Clock Multiplication Division	7-13
Programmable Duty Cycle	7-14
Phase-Shifting Implementation	7-15
Control Signals	7-16
Manual Clock Switchover	7-18
Programmable Bandwidth	7-19
Background	7-19
Implementation	7-22
Software Support	7-23
PLL Specifications	7-24
Clocking	7-24
Global Clock Network	7-25
Clock Control Block	7-28
Global Clock Network Clock Source Generation	7-29
Global Clock Network Power Down	7-31
ckena signals	7-32
Conclusion	7-33

Section III. Memory

Revision History	Section III-1
------------------------	---------------

Chapter 8. Cyclone II Memory Blocks

Introduction	8-1
Overview	8-1
Control Signals	8-3
Parity Bit Support	8-4
Byte Enable Support	8-4

Packed Mode Support	8-6
Address Clock Enable	8-6
Memory Modes	8-8
Single-Port Mode	8-9
Simple Dual-Port Mode	8-10
True Dual-Port Mode	8-12
Shift Register Mode	8-14
ROM Mode	8-15
FIFO Buffer Mode	8-16
Clock Modes	8-16
Independent Clock Mode	8-16
Input/Output Clock Mode	8-18
Read/Write Clock Mode	8-21
Single-Clock Mode	8-22
Power-Up Conditions & Memory Initialization	8-26
Read-During- Write Operation at the Same Address	8-26
Same-Port Read-During-Write Mode	8-27
Mixed-Port Read-During-Write Mode	8-28
Conclusion	8-28

Chapter 9. External Memory Interfaces

Introduction	9-1
External Memory Interface Standards	9-1
DDR & DDR2 SDRAM	9-1
QDRII SRAM	9-4
Cyclone II DDR Memory Support Overview	9-8
Data & Data Strobe Pins	9-9
Clock, Command & Address Pins	9-13
Parity, DM & ECC Pins	9-13
Phase Lock Loop (PLL)	9-13
Clock Delay Control	9-14
DQS Postamble	9-15
DDR Input Registers	9-16
DDR Output Registers	9-20
Bidirectional DDR Registers	9-21
Conclusion	9-23

Section IV. I/O Standards

Revision History	Section IV-1
------------------------	--------------

Chapter 10. Selectable I/O Standards in Cyclone II Devices

Introduction	10-1
Supported I/O Standards	10-1
3.3-V LVTTTL (EIA/JEDEC Standard JESD8-B)	10-3
3.3-V LVCMOS (EIA/JEDEC Standard JESD8-B)	10-4

3.3-V (PCI Special Interest Group [SIG] PCI Local Bus Specification Revision 3.0)	10-4
3.3-V PCI-X	10-6
2.5-V LVTTTL Normal & Wide Voltage Ranges (EIA/JEDEC Standard EIA/JESD8-5)	10-6
2.5-V LVCMOS Normal & Wide Voltage Ranges (EIA/JEDEC Standard EIA/JESD8-5) ..	10-7
SSTL-2 Class I & II (EIA/JEDEC Standard JESD8-9A)	10-7
Pseudo-Differential SSTL-2	10-8
1.8-V LVTTTL Normal & Wide Voltage Ranges (EIA/JEDEC Standard EIA/JESD8-7)	10-9
1.8-V LVCMOS Normal & Wide Voltage Ranges (EIA/JEDEC Standard EIA/JESD8-7) ..	10-9
SSTL-18 Class I & II	10-10
1.8-V HSTL Class I & II	10-11
Pseudo-Differential SSTL-18 Class I & Differential SSTL-18 Class II	10-11
1.8-V Pseudo-Differential HSTL Class I & II	10-13
1.5-V LVCMOS Normal & Wide Voltage Ranges (EIA/JEDEC Standard JESD8-11)	10-14
1.5-V HSTL Class I & II	10-14
1.5-V Pseudo-Differential HSTL Class I & II	10-15
LVDS, RSDS & mini-LVDS	10-16
Differential LVPECL	10-17
Cyclone II I/O Banks	10-18
Programmable Current Drive Strength	10-23
Voltage-Referenced I/O Standard Termination	10-25
Differential I/O Standard Termination	10-25
I/O Driver Impedance Matching (R_S) & Series Termination (R_S)	10-26
Pad Placement & DC Guidelines	10-26
Differential Pad Placement Guidelines	10-26
V_{REF} Pad Placement Guidelines	10-27
DC Guidelines	10-31
Conclusion	10-33
More Information	10-33

Chapter 11. High-Speed Differential Interfaces in Cyclone II Devices

Introduction	11-1
Cyclone II High-Speed I/O Banks	11-2
Cyclone II High-Speed I/O Interface	11-3
I/O Standards Support	11-4
LVDS Standard Support in Cyclone II Devices	11-4
RSDS I/O Standard Support in Cyclone II Devices	11-7
mini-LVDS Standard Support in Cyclone II Devices	11-9
LVPECL Support in Cyclone II	11-11
Differential SSTL Support in Cyclone II Devices	11-12
Differential HSTL Support in Cyclone II Devices	11-13
High-Speed I/O Timing in Cyclone II Devices	11-14
Design Guidelines	11-16
Differential Pad Placement Guidelines	11-16
Board Design Considerations	11-16
Conclusion	11-17

Section V. DSP

Revision History	Section V-1
------------------------	-------------

Chapter 12. Embedded Multipliers in Cyclone II Devices

Introduction	12-1
Embedded Multiplier Block Overview	12-1
Architecture	12-4
Input Registers	12-4
Multiplier Stage	12-5
Output Registers	12-6
Operational Modes	12-6
18-Bit Multipliers	12-6
9-Bit Multipliers	12-7
Software Support	12-9
Conclusion	12-9

Section VI. Configuration & Test

Revision History	Section VI-1
------------------------	--------------

Chapter 13. Configuring Cyclone II Devices

Introduction	13-1
Cyclone II Configuration Overview	13-1
Configuration File Format	13-3
Configuration Data Compression	13-3
Active Serial Configuration (Serial Configuration Devices)	13-6
Single Device AS Configuration	13-7
Multiple Device AS Configuration	13-12
Configuring Multiple Cyclone II Devices with the Same Design	13-15
Estimating AS Configuration Time	13-18
Programming Serial Configuration Devices	13-19
PS Configuration	13-22
Single Device PS Configuration Using a MAX II Device as an External Host	13-22
Multiple Device PS Configuration Using a MAX II Device as an External Host	13-26
PS Configuration Using a Microprocessor	13-31
Single Device PS Configuration Using a Configuration Device	13-32
Multiple Device PS Configuration Using a Configuration Device	13-37
PS Configuration Using a Download Cable	13-48
JTAG Configuration	13-53
Single Device JTAG Configuration	13-55
JTAG Configuration of Multiple Devices	13-58
Jam STAPL	13-60
Configuring Cyclone II FPGAs with JRunner	13-60
Programming Serial Configuration Devices In-System Using the JTAG Interface	13-61
Device Configuration Pins	13-63

Conclusion	13–69
Chapter 14. IEEE 1149.1 (JTAG) Boundary-Scan Testing for Cyclone II Devices	
IEEE Std. 1149.1 BST Architecture	14–2
IEEE Std. 1149.1 Boundary-Scan Register	14–4
Boundary-Scan Cells of a Cyclone II Device I/O Pin	14–4
IEEE Std. 1149.1 BST Operation Control	14–6
SAMPLE/PRELOAD Instruction Mode	14–9
Capture Phase	14–10
Shift & Update Phases	14–10
EXTEST Instruction Mode	14–11
Capture Phase	14–12
Shift & Update Phases	14–12
BYPASS Instruction Mode	14–13
IDCODE Instruction Mode	14–14
USERCODE Instruction Mode	14–14
CLAMP Instruction Mode	14–14
HIGHZ Instruction Mode	14–15
I/O Voltage Support in JTAG Chain	14–15
Using IEEE Std. 1149.1 BST Circuitry	14–16
Disabling IEEE Std. 1149.1 BST Circuitry	14–17
Guidelines for IEEE Std. 1149.1 Boundary-Scan Testing	14–17
Boundary-Scan Description Language (BSDL) Support	14–18
Conclusion	14–18
References	14–18

Section VII. PCB Layout Guidelines

Revision History	Section VII–1
------------------------	---------------

Chapter 15. Package Information for Cyclone II Devices

Introduction	15–1
Thermal Resistance	15–2
Package Outlines	15–2
144-Pin Plastic Thin Quad Flat Pack	15–2
208-Pin Plastic Quad Flat Pack Package	15–5
256-Pin Low Profile FineLine BGA Package	15–7
484-Pin Thermally Enhanced FineLine BGA Package	15–9
672-Pin Thermally Enhanced FineLine BGA Package	15–11
896-Pin Thermally Enhanced FineLine BGA Package	15–13



Chapter Revision Dates

The chapters in this book, *Cyclone II Device Handbook, Volume 1*, were revised on the following dates. Where chapters or groups of chapters are available separately, part numbers are listed.

- Chapter 1. Introduction
Revised: *November 2004*
Part number: *CII51001-1.1*

- Chapter 2. Cyclone II Architecture
Revised: *November 2004*
Part number: *CII51002-1.1*

- Chapter 3. Configuration & Testing
Revised: *November 2004*
Part number: *CII51003-1.1*

- Chapter 4. Hot Socketing, ESD & Power-On Reset
Revised: *June 2004*
Part number: *CII51004-1.0*

- Chapter 5. DC Characteristics & Timing Specifications
Revised: *November 2004*
Part number: *CII51005-1.1*

- Chapter 6. Reference & Ordering Information
Revised: *November 2004*
Part number: *CII51006-1.1*

- Chapter 7. PLLs in Cyclone II Devices
Revised: *November 2004*
Part number: *CII51007-1.1*

- Chapter 8. Cyclone II Memory Blocks
Revised: *June 2004*
Part number: *CII51008-1.0*

- Chapter 9. External Memory Interfaces
Revised: *November 2004*
Part number: *CII51009-1.1*

Chapter 10. Selectable I/O Standards in Cyclone II Devices

Revised: *November 2004*Part number: *CII51010-1.1*

Chapter 11. High-Speed Differential Interfaces in Cyclone II Devices

Revised: *November 2004*Part number: *CII51011-1.1*

Chapter 12. Embedded Multipliers in Cyclone II Devices

Revised: *June 2004*Part number: *CII51012-1.0*

Chapter 13. Configuring Cyclone II Devices

Revised: *November 2004*Part number: *CII51013-1.1*

Chapter 14. IEEE 1149.1 (JTAG) Boundary-Scan Testing for Cyclone II Devices

Revised: *June 2004*Part number: *CII51014-1.0*

Chapter 15. Package Information for Cyclone II Devices

Revised: *November 2004*Part number: *CII51015-1.0*



Section I. Cyclone II Device Family Data Sheet

This section provides information for board layout designers to successfully layout their boards for Cyclone™ II devices. It contains the required PCB layout guidelines, device pin tables, and package specifications.

This section includes the following chapters:

- [Chapter 1. Introduction](#)
- [Chapter 2. Cyclone II Architecture](#)
- [Chapter 3. Configuration & Testing](#)
- [Chapter 4. Hot Socketing, ESD & Power-On Reset](#)
- [Chapter 5. DC Characteristics & Timing Specifications](#)
- [Chapter 6. Reference & Ordering Information](#)

Revision History

The table below shows the revision history for [Chapters 1](#) through [6](#).

Chapter(s)	Date / Version	Changes Made
1	November 2004, v1.1	<ul style="list-style-type: none"> Updated Table 1–2. Updated bullet list in the “Features” section.
	June 2004, v1.0	Added document to the Cyclone II Device Handbook.
2	November 2004, v1.1	Updated Table 2–20 .
	June 2004, v1.0	Added document to the Cyclone II Device Handbook.
3	November 2004, v1.1	Updated Table 3–4 .
	June 2004, v1.0	Added document to the Cyclone II Device Handbook.
4	June 2004, v1.0	Added document to the Cyclone II Device Handbook.
5	November 2004, v1.1	<ul style="list-style-type: none"> Updated the “Differential I/O Standards” section. Updated Table 5–16.
	June 2004, v1.0	Added document to the Cyclone II Device Handbook.
6	November 2004, v1.1	Updated Figure 6–1 .
	June 2004, v1.0	Added document to the Cyclone II Device Handbook.

Introduction

Altera's low-cost Cyclone™ II FPGA family is based on a 1.2-V, 90-nm SRAM process with densities over 68K logic elements (LEs) and up to 1.1 Mbits of embedded RAM. With features like embedded 18×18 multipliers to support high-performance DSP applications, phase-locked loops (PLLs) for system clock management, and high-speed external memory interface support for SRAM and DRAM devices, Cyclone II devices are a cost-effective solution for high-volume applications. Cyclone II devices support differential and single-ended I/O standards, including LVDS at data rates up to 805 megabits per second (Mbps) for the receiver and 622 Mbps for the transmitter, and 64-bit, 66-MHz PCI and PCI-X for interfacing with processors and ASSP and ASIC devices. Altera also offers low-cost serial configuration devices to configure Cyclone II devices. The Cyclone II FPGA family offers commercial grade, industrial grade, and lead-free devices.

Features

The Cyclone II device family offers the following features:

- High-density architecture with 4,608 to 68,288 LEs
- M4K embedded memory blocks
 - Up to 1.1 Mbits of RAM available without reducing available logic
 - 4,096 memory bits per block (4,608 bits per block including 512 parity bits)
 - Variable port configurations of $\times 1$, $\times 2$, $\times 4$, $\times 8$, $\times 9$, $\times 16$, $\times 18$, $\times 32$, and $\times 36$
 - True dual-port (one read and one write, two reads, or two writes) operation for $\times 1$, $\times 2$, $\times 4$, $\times 8$, $\times 9$, $\times 16$, and $\times 18$ modes
 - Byte enables for data input masking during writes
 - Up to 250-MHz operation
- Embedded multipliers
 - 18×18 -bit multipliers are each configurable as two independent 9×9 -bit multipliers with up to 250-MHz performance
 - Optional input and output registers
- Advanced I/O support
 - High-speed differential I/O standard support, including LVDS, RSDS, mini-LVDS, LVPECL, differential HSTL, and differential SSTL
 - Single-ended I/O standard support, including 2.5-V and 1.8-V SSTL class I and II, 1.8-V and 1.5-V HSTL class I and II, 3.3-V PCI

- and PCI-X 1.0, 3.3-, 2.5-, 1.8-, and 1.5-V LVCMOS, and 3.3-, 2.5-, and 1.8-V LVTTL
- Peripheral component interconnect Special Interest Group (PCI SIG) *PCI Local Bus Specification, Revision 3.0* compliance for 3.3-V operation at 33 or 66 MHz for 32- or 64-bit interfaces
- 100-MHz PCI-X 1.0 specification compatibility
- High-speed external memory support, including DDR, DDR2, and SDR SDRAM, and QDR II SRAM
- Three dedicated registers per I/O element (IOE): one input register, one output register, and one output-enable register
- Programmable bus-hold feature
- Programmable output drive strength feature
- Programmable delays from the pin to the IOE or logic array
- I/O bank grouping for unique V_{CCIO} and/or V_{REF} bank settings
- MultiVolt™ I/O standard support for 1.5-, 1.8-, 2.5-, and 3.3-V interfaces
- Hot-socketing operation support
- Tri-state with weak pull-up on I/O pins before and during configuration
- Programmable open-drain outputs
- Series on-chip termination support
- Flexible clock management circuitry
 - Hierarchical clock network for up to 402.5-MHz performance
 - Up to four PLLs per device provide clock multiplication and division, phase shifting, programmable duty cycle, and external clock outputs, allowing system-level clock management and skew control
 - Up to 16 global clock lines in the global clock network that drive throughout the entire device
- Device configuration
 - Fast serial configuration allows configuration times less than 100 ms
 - Decompression feature allows for smaller programming file storage and faster configuration times
 - Supports multiple configuration modes: active serial, passive serial, and JTAG-based configuration
 - Supports configuration through low-cost serial configuration devices
 - Device configuration supports multiple voltages (either 3.3, 2.5, or 1.8 V)
- Intellectual property
 - Altera megafunction support
 - Altera MegaCore® function support
 - Altera Megafunctions Partners Program (AMPPSM) megafunctions support

Table 1–1 lists the Cyclone II device family features. Table 1–2 lists the Cyclone II device package offerings and maximum user I/O pins.

Feature	EP2C5	EP2C8	EP2C20	EP2C35	EP2C50	EP2C70
LEs	4,608	8,256	18,752	33,216	50,528	68,416
M4K RAM blocks (4 Kbits plus 512 parity bits)	26	36	52	105	129	250
Total RAM bits	119,808	165,888	239,616	483,840	594,432	1,152,000
Embedded multipliers (1)	13	18	26	35	86	150
PLLs	2	2	4	4	4	4
Maximum user I/O pins	142	182	315	475	450	622

Note to Table 1–1:

- (1) This is the total number of 18×18 multipliers. For the total number of 9×9 multipliers per device, multiply the total number of 18×18 multipliers by 2.

Device	144-Pin TQFP (2)	208-Pin PQFP (3)	256-Pin FineLine BGA	484-Pin FineLine BGA	672-Pin FineLine BGA	896-Pin FineLine BGA
EP2C5 (5)	89	142	(4)			
EP2C8 (5)	85	138	182			
EP2C20 (5)		(4)	152	315		
EP2C35 (5)				322	475	
EP2C50 (5)				294	450	
EP2C70 (5)					422	622

Notes to Table 1–2:

- (1) Cyclone II devices support vertical migration within the same package (for example, designers can migrate between the EP2C20 device in the 484-pin FineLine BGA® package and the EP2C35 and EP2C50 devices in the same package).
- (2) TQFP: thin quad flat pack.
- (3) PQFP: plastic quad flat pack.
- (4) Contact your local Altera sales representative for more information on this device.
- (5) The I/O pin counts for the EP2C5 and EP2C8 devices include 8 dedicated clock pins that can be used for data inputs. The I/O counts for the EP2C20, EP2C35, EP2C50, and EP2C70 devices include 16 dedicated clock pins that can be used for data inputs.

Functional Description

Cyclone™ II devices contain a two-dimensional row- and column-based architecture to implement custom logic. Column and row interconnects of varying speeds provide signal interconnects between logic array blocks (LABs), embedded memory blocks, and embedded multipliers.

The logic array consists of LABs, with 16 logic elements (LEs) in each LAB. An LE is a small unit of logic providing efficient implementation of user logic functions. LABs are grouped into rows and columns across the device. Cyclone II devices range in density from 4,608 to 68,416 LEs.

Cyclone II devices provide a global clock network and up to four phase-locked loops (PLLs). The global clock network consists of up to 16 global clock lines that drive throughout the entire device. The global clock network can provide clocks for all resources within the device, such as input/output elements (IOEs), LEs, embedded multipliers, and embedded memory blocks. The global clock lines can also be used for other high fan-out signals. Cyclone II PLLs provide general-purpose clocking with clock synthesis and phase shifting as well as external outputs for high-speed differential I/O support.

M4K memory blocks are true dual-port memory blocks with 4K bits of memory plus parity (4,608 bits). These blocks provide dedicated true dual-port, simple dual-port, or single-port memory up to 36-bits wide at up to 250 MHz. These blocks are arranged in columns across the device in between certain LABs. Cyclone II devices offer between 119 to 1,152 Kbits of embedded memory.

Each embedded multiplier block can implement up to either two 9×9 -bit multipliers, or one 18×18 -bit multiplier with up to 250-MHz performance. Embedded multipliers are arranged in columns across the device.

Each Cyclone II device I/O pin is fed by an IOE located at the ends of LAB rows and columns around the periphery of the device. I/O pins support various single-ended and differential I/O standards, such as the 66- and 33-MHz, 64- and 32-bit PCI standard, PCI-X, and the LVDS I/O standard at a maximum data rate of 805 megabits per second (Mbps) for inputs and 622 Mbps for outputs. Each IOE contains a bidirectional I/O buffer and three registers for registering input, output, and output-enable signals. Dual-purpose DQS, DQ, and DM pins along with delay chains (used to

phase-align double data rate (DDR) signals) provide interface support for external memory devices such as DDR, DDR2, and single data rate (SDR) SDRAM, and QDR II SRAM devices at up to 167 MHz.

Figure 2–1 shows a diagram of the Cyclone II EP2C20 device.

Figure 2–1. Cyclone II EP2C20 Device Block Diagram

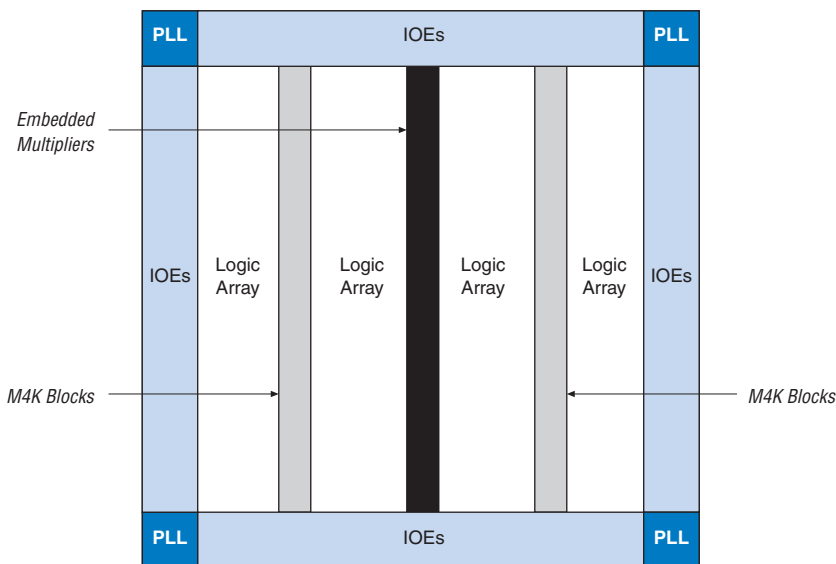

The number of M4K memory blocks, embedded multiplier blocks, PLLs, rows, and columns vary per device. Table 2–1 lists the resources available in each Cyclone II device.

Table 2–1. Cyclone II Device Resources

Device	LAB Columns	LAB Rows	LEs	PLLs	M4K Memory Blocks	Embedded Multiplier Blocks
EP2C5	24	13	4,608	2	26	13
EP2C8	30	18	8,256	2	36	18
EP2C20	46	26	18,752	4	52	26
EP2C35	60	35	33,216	4	105	35
EP2C50	74	43	50,528	4	129	86
EP2C70	86	50	68,416	4	250	150

Logic Elements

The smallest unit of logic in the Cyclone II architecture, the LE, is compact and provides advanced features with efficient logic utilization. Each LE features:

- A four-input look-up table (LUT), which is a function generator that can implement any function of four variables
- A programmable register
- A carry chain connection
- A register chain connection
- The ability to drive all types of interconnects: local, row, column, register chain, and direct link interconnects
- Support for register packing
- Support for register feedback

Figure 2-2 shows a Cyclone II LE.

Figure 2-2. Cyclone II LE

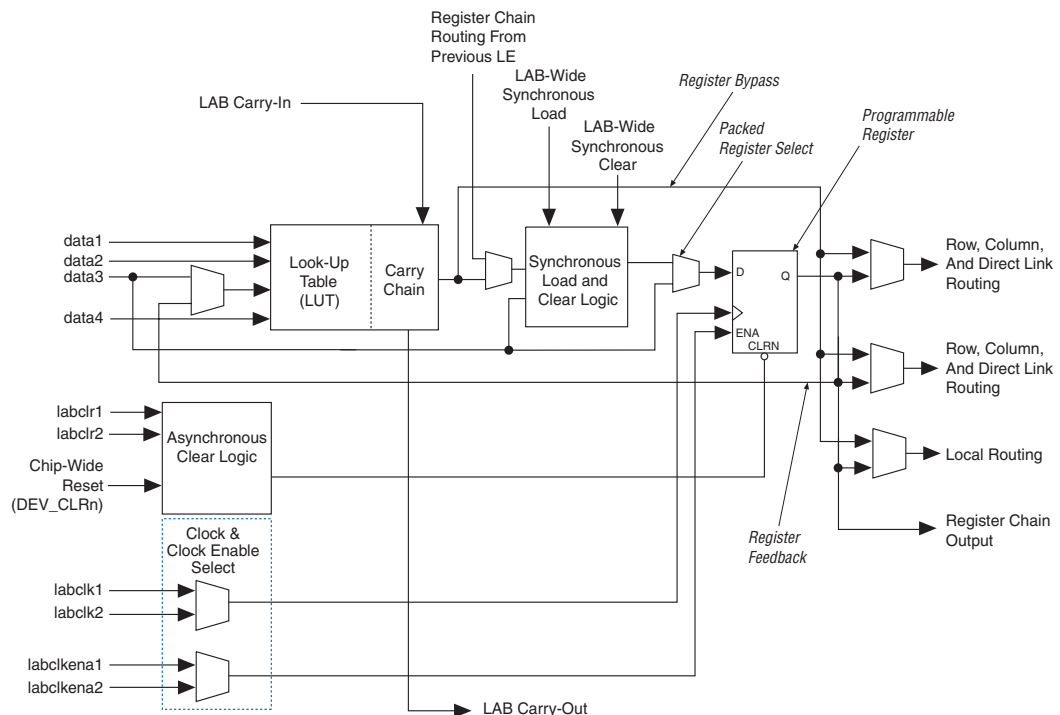

Each LE's programmable register can be configured for D, T, JK, or SR operation. Each register has data, clock, clock enable, and clear inputs. Signals that use the global clock network, general-purpose I/O pins, or any internal logic can drive the register's clock and clear control signals. Either general-purpose I/O pins or internal logic can drive the clock enable. For combinatorial functions, the LUT output bypasses the register and drives directly to the LE outputs.

Each LE has three outputs that drive the local, row, and column routing resources. The LUT or register output can drive these three outputs independently. Two LE outputs drive column or row and direct link routing connections and one drives local interconnect resources, allowing the LUT to drive one output while the register drives another output. This feature, register packing, improves device utilization because the device can use the register and the LUT for unrelated functions. When using register packing, the LAB-wide synchronous load control signal is not available. See [“LAB Control Signals” on page 2–8](#) for more information.

Another special packing mode allows the register output to feed back into the LUT of the same LE so that the register is packed with its own fan-out LUT, providing another mechanism for improved fitting. The LE can also drive out registered and unregistered versions of the LUT output.

In addition to the three general routing outputs, the LEs within an LAB have register chain outputs. Register chain outputs allow registers within the same LAB to cascade together. The register chain output allows an LAB to use LUTs for a single combinatorial function and the registers to be used for an unrelated shift register implementation. These resources speed up connections between LABs while saving local interconnect resources. See [“MultiTrack Interconnect” on page 2–10](#) for more information on register chain connections.

LE Operating Modes

The Cyclone II LE operates in one of the following modes:

- Normal mode
- Arithmetic mode

Each mode uses LE resources differently. In each mode, six available inputs to the LE—the four data inputs from the LAB local interconnect, the LAB carry-in from the previous carry-chain LAB, and the register chain connection—are directed to different destinations to implement the desired logic function. LAB-wide signals provide clock, asynchronous clear, synchronous clear, synchronous load, and clock enable control for the register. These LAB-wide signals are available in all LE modes.

The Quartus II software, in conjunction with parameterized functions such as library of parameterized modules (LPM) functions, automatically chooses the appropriate mode for common functions such as counters, adders, subtractors, and arithmetic functions. If required, the designer can also create special-purpose functions that specify which LE operating mode to use for optimal performance.

Normal Mode

The normal mode is suitable for general logic applications and combinatorial functions. In normal mode, four data inputs from the LAB local interconnect are inputs to a four-input LUT (see Figure 2-3). The Quartus II Compiler automatically selects the carry-in or the data3 signal as one of the inputs to the LUT. LEs in normal mode support packed registers and register feedback.

Figure 2-3. LE in Normal Mode

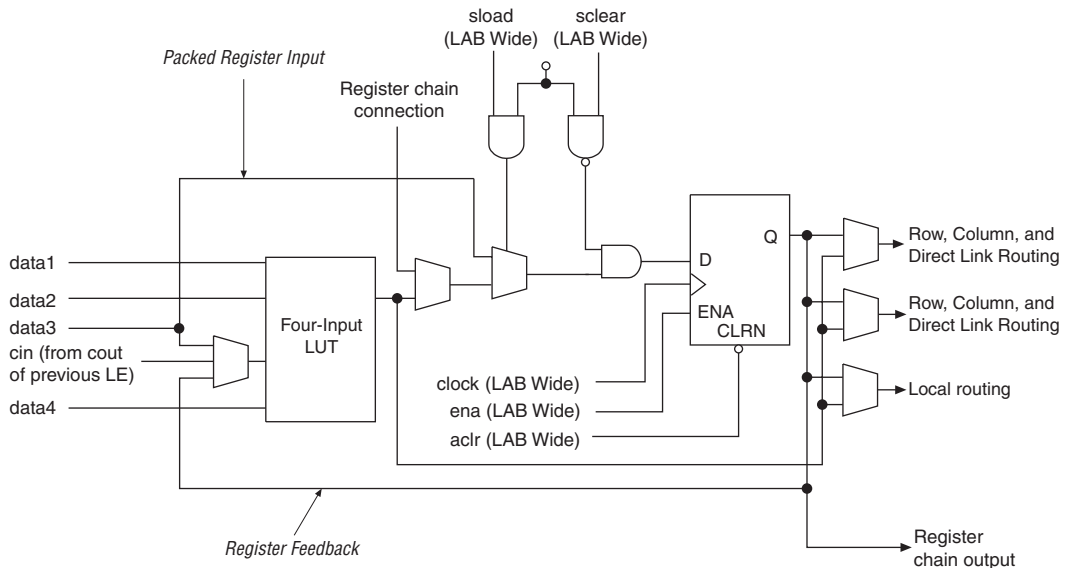

Arithmetic Mode

The arithmetic mode is ideal for implementing adders, counters, accumulators, and comparators. An LE in arithmetic mode implements a 2-bit full adder and basic carry chain (see Figure 2–4). LEs in arithmetic mode can drive out registered and unregistered versions of the LUT output. Register feedback and register packing are supported when LEs are used in arithmetic mode.

Figure 2–4. LE in Arithmetic Mode

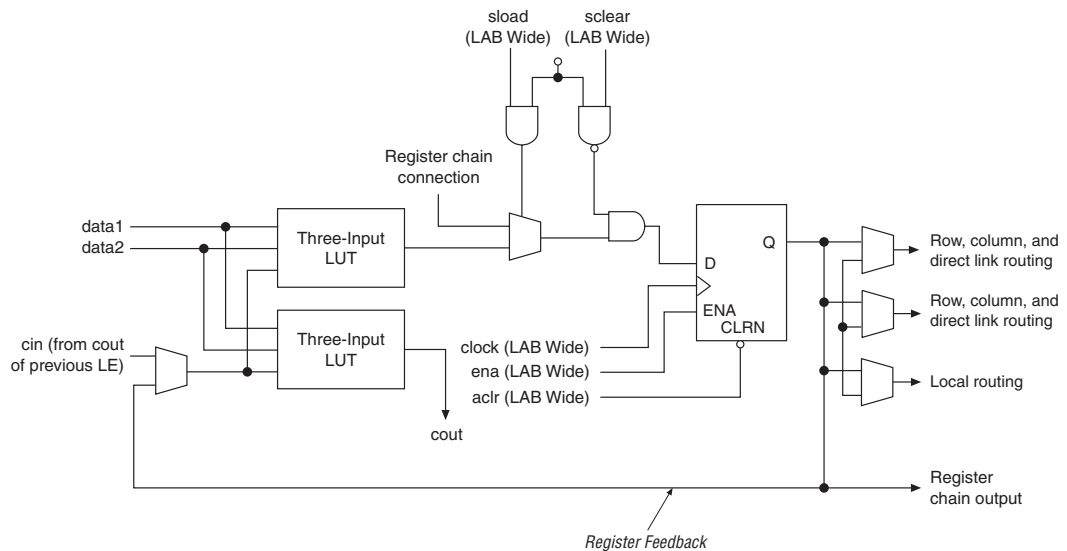

The Quartus II Compiler automatically creates carry chain logic during design processing, or the designer can create it manually during design entry. Parameterized functions such as LPM functions automatically take advantage of carry chains for the appropriate functions.

The Quartus II Compiler creates carry chains longer than 16 LEs by automatically linking LABs in the same column. For enhanced fitting, a long carry chain runs vertically, which allows fast horizontal connections to M4K memory blocks or embedded multipliers through direct link interconnects. For example, if a design has a long carry chain in a LAB column next to a column of M4K memory blocks, any LE output can feed an adjacent M4K memory block through the direct link interconnect. Whereas if the carry chains ran horizontally, any LAB not next to the column of M4K memory blocks would use other row or column interconnects to drive a M4K memory block. A carry chain continues as far as a full column.

Logic Array Blocks

Each LAB consists of:

- 16 LEs
- LAB control signals
- LE carry chains
- Register chains
- Local interconnect

The local interconnect transfers signals between LEs in the same LAB. Register chain connections transfer the output of one LE's register to the adjacent LE's register within an LAB. The Quartus® II Compiler places associated logic within an LAB or adjacent LABs, allowing the use of local, and register chain connections for performance and area efficiency. Figure 2-5 shows the Cyclone II LAB.

Figure 2-5. Cyclone II LAB Structure

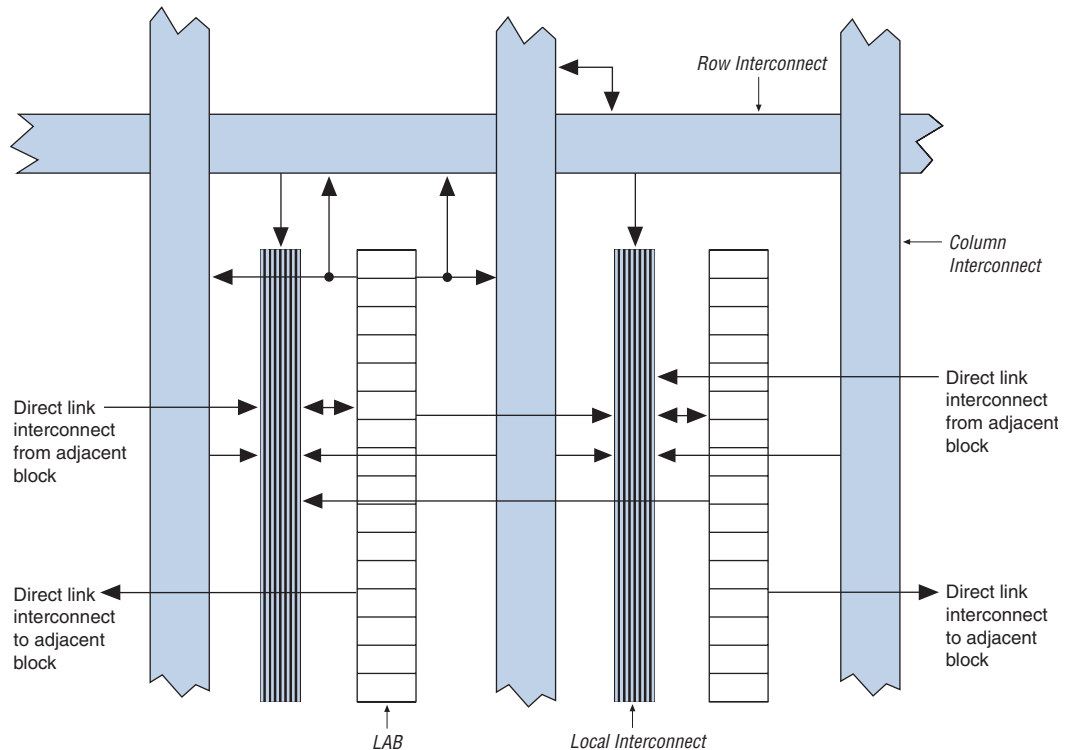

LAB Interconnects

The LAB local interconnect can drive LEs within the same LAB. The LAB local interconnect is driven by column and row interconnects and LE outputs within the same LAB. Neighboring LABs, PLLs, M4K RAM blocks, and embedded multipliers from the left and right can also drive an LAB's local interconnect through the direct link connection. The direct link connection feature minimizes the use of row and column interconnects, providing higher performance and flexibility. Each LE can drive 48 LEs through fast local and direct link interconnects. [Figure 2-6](#) shows the direct link connection.

Figure 2-6. Direct Link Connection

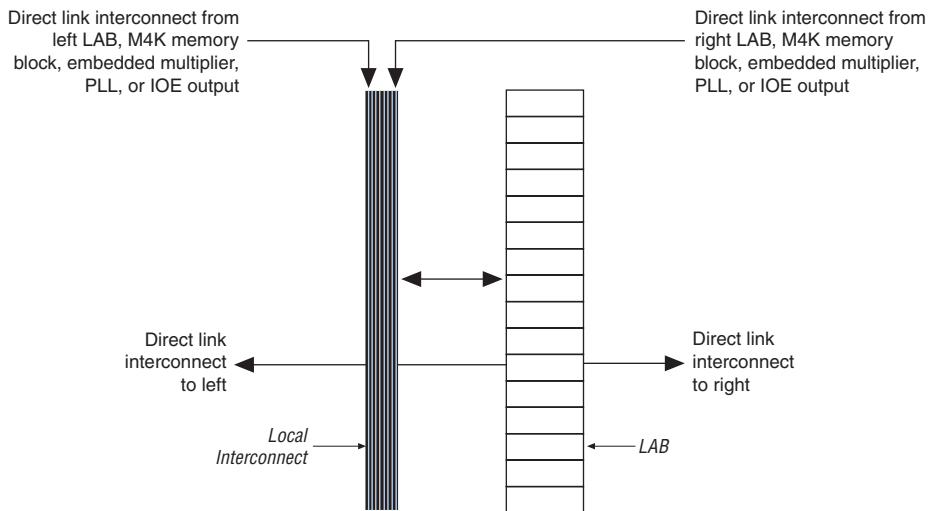

LAB Control Signals

Each LAB contains dedicated logic for driving control signals to its LEs. The control signals include:

- Two clocks
- Two clock enables
- Two asynchronous clears
- One synchronous clear
- One synchronous load

This gives a maximum of seven control signals at a time. When using the LAB-wide synchronous load, the `clkena` of `labclk1` is not available. Additionally, register packing and synchronous load cannot be used simultaneously.

Each LAB can have up to four non-global control signals. Additional LAB control signals can be used as long as they are global signals.

Synchronous clear and load signals are useful for implementing counters and other functions. The synchronous clear and synchronous load signals are LAB-wide signals that affect all registers in the LAB.

Each LAB can use two clocks and two clock enable signals. Each LAB's clock and clock enable signals are linked. For example, any LE in a particular LAB using the `labclk1` signal also uses `labclkena1`. If the LAB uses both the rising and falling edges of a clock, it also uses both LAB-wide clock signals. De-asserting the clock enable signal turns off the LAB-wide clock.

The LAB row clocks [5..0] and LAB local interconnect generate the LAB-wide control signals. The MultiTrack™ interconnect's inherent low skew allows clock and control signal distribution in addition to data. [Figure 2-7](#) shows the LAB control signal generation circuit.

Figure 2-7. LAB-Wide Control Signals

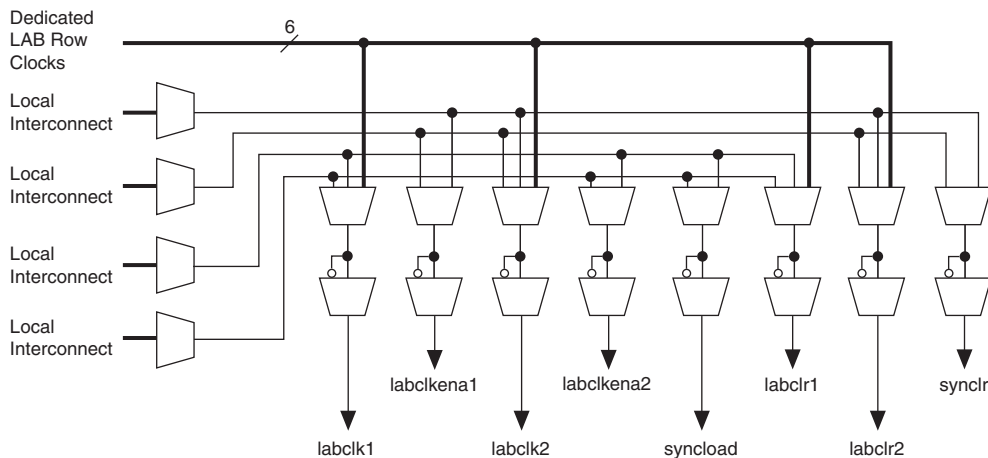

LAB-wide signals control the logic for the register's clear signal. The LE directly supports an asynchronous clear function. Each LAB supports up to two asynchronous clear signals (`labclr1` and `labclr2`).

A LAB-wide asynchronous load signal to control the logic for the register's preset signal is not available. The register preset is achieved by using a NOT gate push-back technique. Cyclone II devices can only support either a preset or asynchronous clear signal.

In addition to the clear port, Cyclone II devices provide a chip-wide reset pin (`DEV_CLRn`) that resets all registers in the device. An option set before compilation in the Quartus II software controls this pin. This chip-wide reset overrides all other control signals.

MultiTrack Interconnect

In the Cyclone II architecture, connections between LEs, M4K memory blocks, embedded multipliers, and device I/O pins are provided by the MultiTrack interconnect structure with DirectDrive™ technology. The MultiTrack interconnect consists of continuous, performance-optimized routing lines of different speeds used for inter- and intra-design block connectivity. The Quartus II Compiler automatically places critical paths on faster interconnects to improve design performance.

DirectDrive technology is a deterministic routing technology that ensures identical routing resource usage for any function regardless of placement within the device. The MultiTrack interconnect and DirectDrive technology simplify the integration stage of block-based designing by eliminating the re-optimization cycles that typically follow design changes and additions.

The MultiTrack interconnect consists of row (direct link, R4, and R24) and column (register chain, C4, and C16) interconnects that span fixed distances. A routing structure with fixed-length resources for all devices allows predictable and repeatable performance when migrating through different device densities.

Row Interconnects

Dedicated row interconnects route signals to and from LABs, PLLs, M4K memory blocks, and embedded multipliers within the same row. These row resources include:

- Direct link interconnects between LABs and adjacent blocks
- R4 interconnects traversing four blocks to the right or left
- R24 interconnects for high-speed access across the length of the device

The direct link interconnect allows an LAB, M4K memory block, or embedded multiplier block to drive into the local interconnect of its left and right neighbors. Only one side of a PLL block interfaces with direct link and row interconnects. The direct link interconnect provides fast communication between adjacent LABs and/or blocks without using row interconnect resources.

The R4 interconnects span four LABs, three LABs and one M4K memory block, or three LABs and one embedded multiplier to the right or left of a source LAB. These resources are used for fast row connections in a four-LAB region. Every LAB has its own set of R4 interconnects to drive either left or right. [Figure 2–8](#) shows R4 interconnect connections from an LAB. R4 interconnects can drive and be driven by LABs, M4K memory blocks, embedded multipliers, PLLs, and row IOEs. For LAB interfacing, a primary LAB or LAB neighbor (see [Figure 2–8](#)) can drive a given R4 interconnect. For R4 interconnects that drive to the right, the primary LAB and right neighbor can drive on to the interconnect. For R4 interconnects that drive to the left, the primary LAB and its left neighbor can drive on to the interconnect. R4 interconnects can drive other R4 interconnects to extend the range of LABs they can drive. Additionally, R4 interconnects can drive R24 interconnects, C4, and C16 interconnects for connections from one row to another.

Figure 2–8. R4 Interconnect Connections

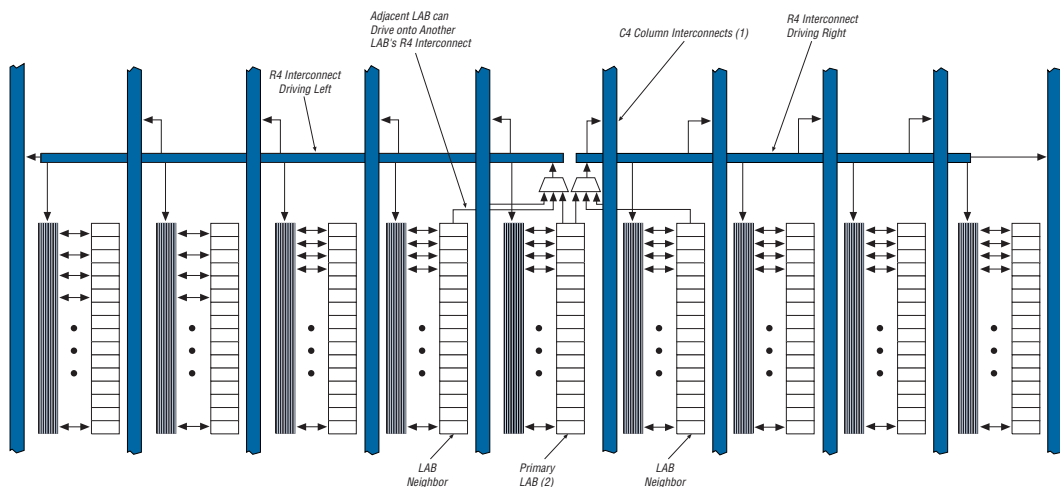

Notes to [Figure 2–8](#):

- (1) C4 interconnects can drive R4 interconnects.
- (2) This pattern is repeated for every LAB in the LAB row.

R24 row interconnects span 24 LABs and provide the fastest resource for long row connections between non-adjacent LABs, M4K memory blocks, dedicated multipliers, and row IOEs. R24 row interconnects drive to other row or column interconnects at every fourth LAB. R24 row interconnects drive LAB local interconnects via R4 and C4 interconnects and do not drive directly to LAB local interconnects. R24 interconnects can drive R24, R4, C16, and C4 interconnects.

Column Interconnects

The column interconnect operates similar to the row interconnect. Each column of LABs is served by a dedicated column interconnect, which vertically routes signals to and from LABs, M4K memory blocks, embedded multipliers, and row and column IOEs. These column resources include:

- Register chain interconnects within an LAB
- C4 interconnects traversing a distance of four blocks in an up and down direction
- C16 interconnects for high-speed vertical routing through the device

Cyclone II devices include an enhanced interconnect structure within LABs for routing LE output to LE input connections faster using register chain connections. The register chain connection allows the register output of one LE to connect directly to the register input of the next LE in the LAB for fast shift registers. The Quartus II Compiler automatically takes advantage of these resources to improve utilization and performance. [Figure 2-9](#) shows the register chain interconnects.

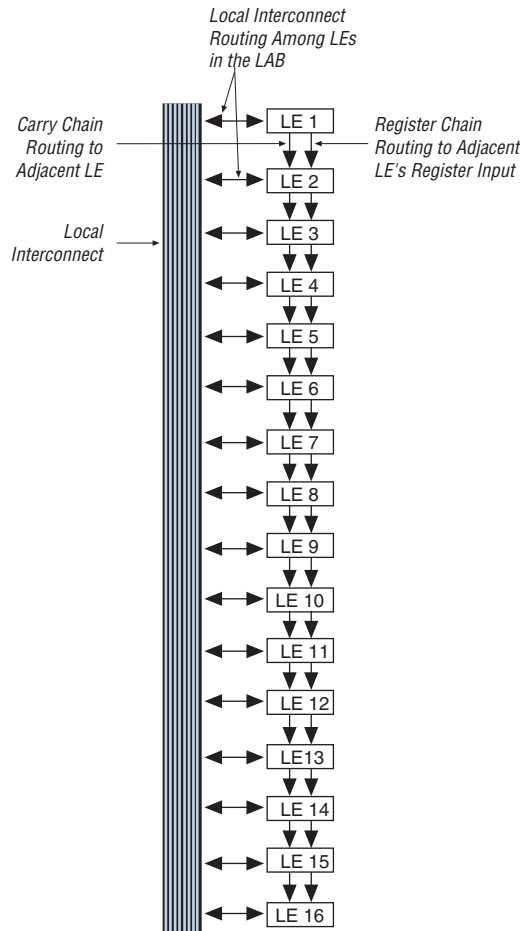
Figure 2–9. Register Chain Interconnects

The C4 interconnects span four LABs, M4K blocks, or embedded multipliers up or down from a source LAB. Every LAB has its own set of C4 interconnects to drive either up or down. [Figure 2–10](#) shows the C4 interconnect connections from an LAB in a column. The C4 interconnects can drive and be driven by all types of architecture blocks, including PLLs, M4K memory blocks, embedded multiplier blocks, and column and row IOEs. For LAB interconnection, a primary LAB or its LAB neighbor (see [Figure 2–10](#)) can drive a given C4 interconnect. C4 interconnects can drive each other to extend their range as well as drive row interconnects for column-to-column connections.

Figure 2-10. C4 Interconnect Connections *Note (1)*

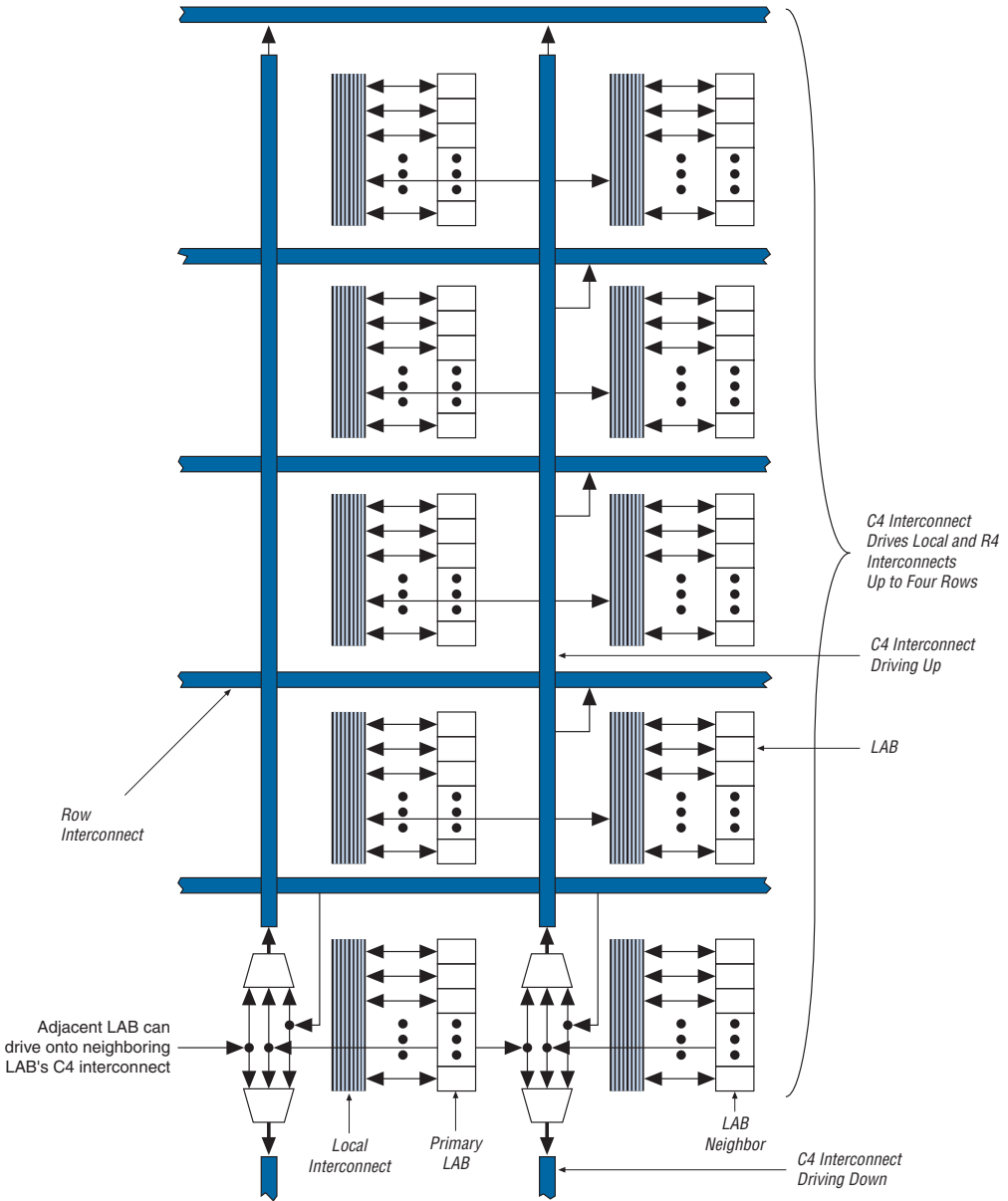

Note to Figure 2-10:

(1) Each C4 interconnect can drive either up or down four rows.

C16 column interconnects span a length of 16 LABs and provide the fastest resource for long column connections between LABs, M4K memory blocks, embedded multipliers, and IOEs. C16 column interconnects drive to other row and column interconnects at every fourth LAB. C16 column interconnects drive LAB local interconnects via C4 and R4 interconnects and do not drive LAB local interconnects directly. C16 interconnects can drive R24, R4, C16, and C4 interconnects.

Device Routing

All embedded blocks communicate with the logic array similar to LAB-to-LAB interfaces. Each block (for example, M4K memory, embedded multiplier, or PLL) connects to row and column interconnects and has local interconnect regions driven by row and column interconnects. These blocks also have direct link interconnects for fast connections to and from a neighboring LAB.

Table 2–2 shows the Cyclone II device’s routing scheme.

Table 2–2. Cyclone II Device Routing Scheme (Part 1 of 2)

Source	Destination												
	Register Chain	Local Interconnect	Direct Link Interconnect	R4 Interconnect	R24 Interconnect	C4 Interconnect	C16 Interconnect	LE	M4K RAM Block	Embedded Multiplier	PLL	Column IOE	Row IOE
Register Chain								✓					
Local Interconnect								✓	✓	✓	✓	✓	✓
Direct Link Interconnect		✓											
R4 Interconnect		✓		✓	✓	✓	✓						
R24 Interconnect				✓	✓	✓	✓						
C4 Interconnect		✓		✓	✓	✓	✓						
C16 Interconnect				✓	✓	✓	✓						

Table 2–2. Cyclone II Device Routing Scheme (Part 2 of 2)

Source	Destination												
	Register Chain	Local Interconnect	Direct Link Interconnect	R4 Interconnect	R24 Interconnect	C4 Interconnect	C16 Interconnect	LE	M4K RAM Block	Embedded Multiplier	PLL	Column IOE	Row IOE
LE	✓	✓	✓	✓		✓							
M4K memory Block		✓	✓	✓		✓							
Embedded Multipliers		✓	✓	✓		✓							
PLL			✓	✓		✓							
Column IOE						✓	✓						
Row IOE			✓	✓	✓	✓							

Global Clock Network & Phase-Locked Loops

Cyclone II devices provide global clock networks and up to four PLLs for a complete clock management solution. Cyclone II clock network features include:

- Up to 16 global clock networks
- Up to four PLLs
- Global clock network dynamic clock source selection
- Global clock network dynamic enable and disable

Each global clock network has a clock control block to select from a number of input clock sources (PLL clock outputs, CLK [] pins, DPCLK [] pins, and internal logic) to drive onto the global clock network. Table 2-3 lists how many PLLs, CLK [] pins, DPCLK [] pins, and global clock networks are available in each Cyclone II device. CLK [] pins are dedicated clock pins and DPCLK [] pins are dual-purpose clock pins.

Table 2-3. Cyclone II Device Clock Resources

Device	Number of PLLs	Number of CLK Pins	Number of DPCLK Pins	Number of Global Clock Networks
EP2C5	2	8	8	8
EP2C8	2	8	8	8
EP2C20	4	16	20	16
EP2C35	4	16	20	16
EP2C50	4	16	20	16
EP2C70	4	16	20	16

Figures 2-11 and 2-12 show the location of the Cyclone II PLLs, CLK [] inputs, DPCLK [] pins, and clock control blocks.

Figure 2-11. EP2C5 & EP2C8 PLL, CLK[], DPCLK[] & Clock Control Block Locations

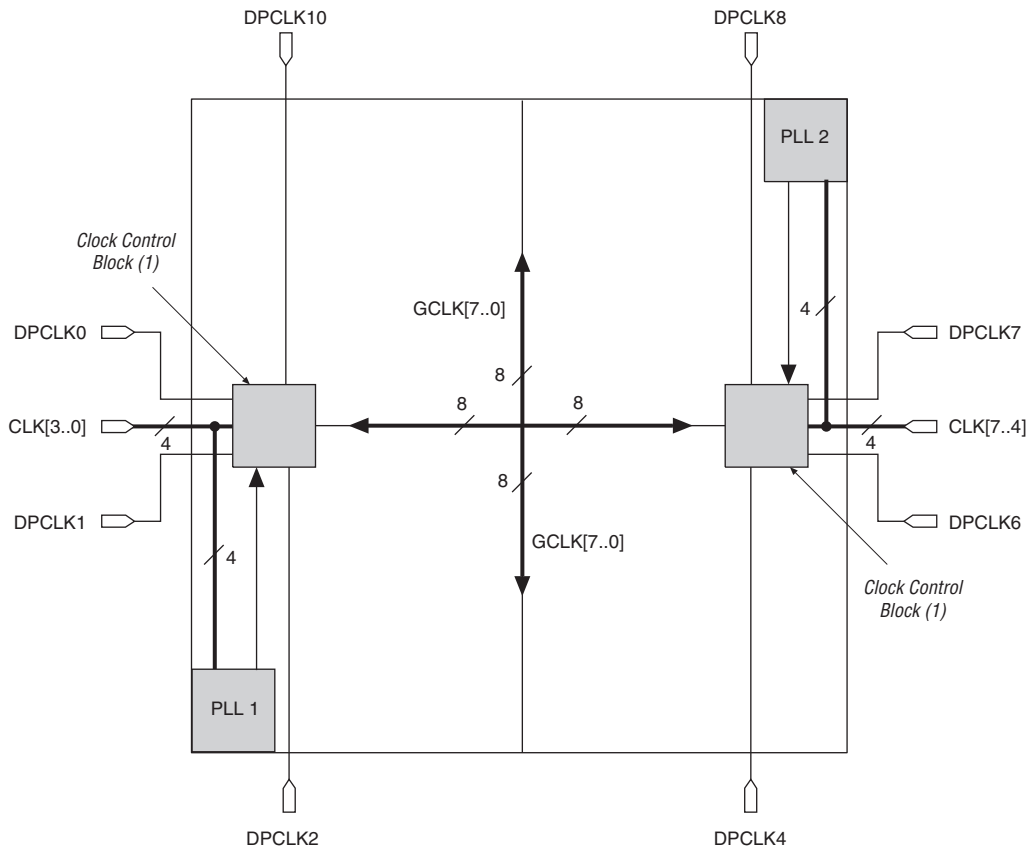

Note to Figure 2-11:

(1) There are four clock control blocks on each side.

Figure 2–12. EP2C20 & Larger PLL, CLK[], DPCLK[] & Clock Control Block Locations

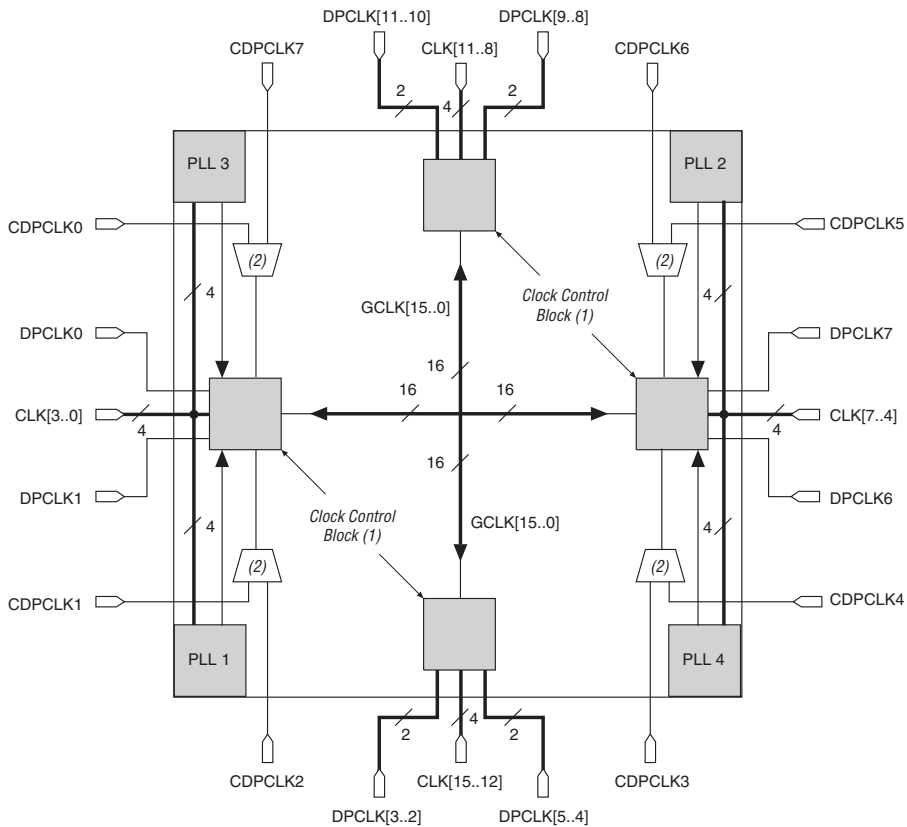

Notes to Figure 2–12:

- (1) There are four clock control blocks on each side.
- (2) Only one of the corner CDPCLK pins in each corner can feed the clock control block at a time. The other CDPCLK pins can be used as general-purpose I/O pins.

Dedicated Clock Pins

Larger Cyclone II devices (EP2C20 and larger devices) have 16 dedicated clock pins (CLK [15 . . 0], four pins on each side of the device). Smaller Cyclone II devices (EP2C5 and EP2C8 devices) have eight dedicated clock pins (CLK [7 . . 0], four pins on left and right sides of the device). These CLK pins drive the global clock network (GCLK), as shown in [Figures 2–11](#) and [2–12](#).

If the dedicated clock pins are not used to feed the global clock networks, they can be used as general-purpose input pins to feed the logic array using the MultiTrack interconnect. However, if they are used as general-purpose input pins, they do not have support for an I/O register and must use LE-based registers in place of an I/O register.

Dual-Purpose Clock Pins

Cyclone II devices have either 20 dual-purpose clock pins, $DPCLK[19..0]$ or 8 dual-purpose clock pins, $DPCLK[7..0]$. In the larger Cyclone II devices (EP2C20 devices and higher), there are 20 $DPCLK$ pins; four on the left and right sides and six on the top and bottom of the device. The corner $CDPCLK$ pins are first multiplexed before they drive into the clock control block. Since the signals pass through a multiplexer before feeding the clock control block, these signals incur more delay to the clock control block than other $DPCLK$ pins that directly feed the clock control block. In the smaller Cyclone II devices (EP2C5 and EP2C8 devices), there are eight $DPCLK$ pins; two on each side of the device (see [Figures 2–11](#) and [2–12](#)).

A programmable delay chain is available from the $DPCLK$ pin to its fan-out destinations. To set the propagation delay from the $DPCLK$ pin to its fan-out destinations, use the **Input Delay from Dual-Purpose Clock Pin to Fan-Out Destinations** assignment in the Quartus II software.

These dual-purpose pins can connect to the global clock network for high-fanout control signals such as clocks, asynchronous clears, presets, and clock enables, or protocol control signals such as $TRDY$ and $IRDY$ for PCI, or DQS signals for external memory interfaces.

Global Clock Network

The 16 or 8 global clock networks drive throughout the entire device. Dedicated clock pins ($CLK[]$), PLL outputs, the logic array, and dual-purpose clock ($DPCLK[]$) pins can also drive the global clock network.

The global clock network can provide clocks for all resources within the device, such as IOEs, LEs, memory blocks, and embedded multipliers. The global clock lines can also be used for control signals, such as clock enables and synchronous or asynchronous clears fed from the external pin, or DQS signals for DDR SDRAM or QDR II SRAM interfaces. Internal logic can also drive the global clock network for internally generated global clocks and asynchronous clears, clock enables, or other control signals with large fan-out.

Clock Control Block

There is a clock control block for each global clock network available in Cyclone II devices. The clock control blocks are arranged on the device periphery and there are a maximum of 16 clock control blocks available per Cyclone II device. The larger Cyclone II devices (EP2C20 devices and larger) have 16 clock control blocks, four on each side of the device. The smaller Cyclone II devices (EP2C5 and EP2C8 devices) have eight clock control blocks, four on the left and right sides of the device.

The control block has these functions:

- Dynamic global clock network clock source selection
- Dynamic enable/disable of the global clock network

In Cyclone II devices, the dedicated CLK [] pins, PLL counter outputs, DPCLK [] pins, and internal logic can all feed the clock control block. The output from the clock control block in turn feeds the corresponding global clock network.

The following sources can be inputs to a given clock control block:

- Four clock pins on the same side as the clock control block
- Three PLL clock outputs from a PLL
- Four DPCLK pins (including CDPCLK pins) on the same side as the clock control block
- Four internally-generated signals

Of the sources listed, only two clock pins, two PLL clock outputs, one DPCLK pin, and one internally-generated signal are chosen to drive into a clock control block. [Figure 2-13](#) shows a more detailed diagram of the clock control block. Out of these six inputs, the two clock input pins and two PLL outputs can be dynamic selected to feed a global clock network. The clock control block supports static selection of DPCLK and the signal from internal logic.

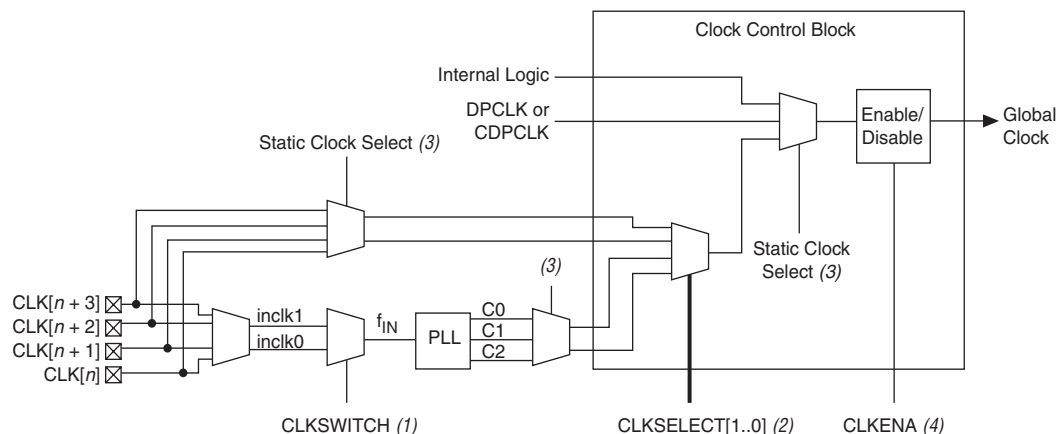
Figure 2–13. Clock Control Block**Notes to Figure 2–13:**

- (1) The $CLKSWITCH$ signal can either be set through the configuration file or it can be dynamically set when using the manual PLL switchover feature. The output of the multiplexer is the input reference clock (f_{IN}) for the PLL.
- (2) The $CLKSELECT[1..0]$ signals are fed by internal logic and can be used to dynamically select the clock source for the global clock network when the device is in user mode.
- (3) The static clock select signals are set in the configuration file and cannot be dynamically controlled when the device is in user mode.
- (4) Internal logic can be used to enable or disable the global clock network in user mode.

Global Clock Network Distribution

Cyclone II devices contain 16 global clock networks. The device uses multiplexers with these clocks to form six-bit buses to drive column IOE clocks, LAB row clocks, or row IOE clocks (see Figure 2–14). Another multiplexer at the LAB level selects two of the six LAB row clocks to feed the LE registers within the LAB.

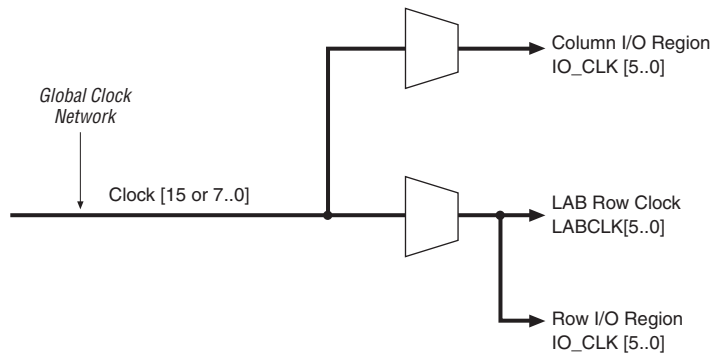
Figure 2–14. Global Clock Network Multiplexers

LAB row clocks can feed LEs, M4K memory blocks, and embedded multipliers. The LAB row clocks also extend to the row I/O clock regions.

IOE clocks are associated with row or column block regions. Only six global clock resources feed to these row and column regions. [Figure 2–15](#) shows the I/O clock regions.

Figure 2-15. LAB & I/O Clock Regions

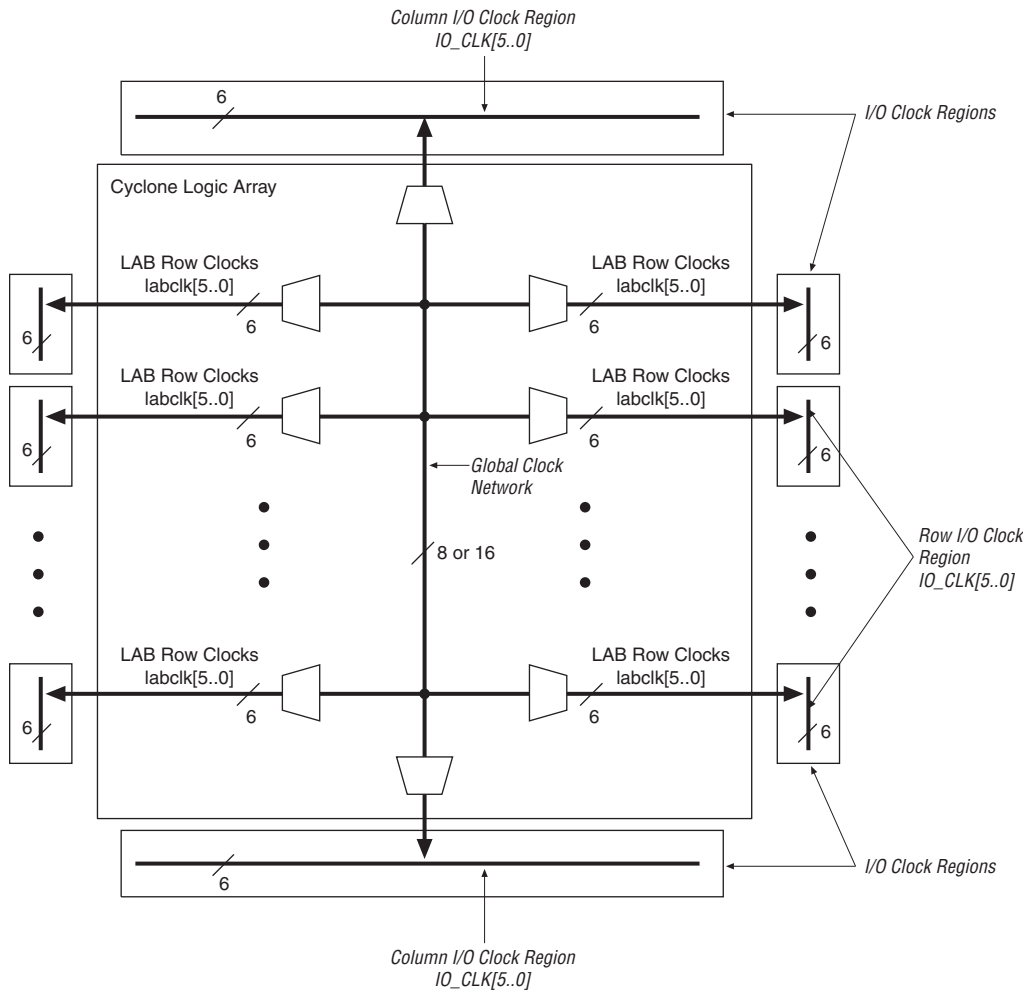

For more information on the global clock network and the clock control block, see the PLLs in *Cyclone II Devices* chapter in Volume 1 of the *Cyclone II Device Handbook*.

PLLs

Cyclone II PLLs provide general-purpose clocking as well as support for the following features:

- Clock multiplication and division
- Phase shifting
- Programmable duty cycle
- Up to three internal clock outputs
- One dedicated external clock output
- Clock outputs for differential I/O support
- Manual clock switchover
- Programmable bandwidth
- Gated lock signal
- Three different clock feedback modes
- Control signals

Cyclone II devices contain either two or four PLLs. [Table 2-4](#) shows the PLLs available for each Cyclone II device.

Device	PLL1	PLL2	PLL3	PLL4
EP2C5	✓	✓		
EP2C8	✓	✓		
EP2C20	✓	✓	✓	✓
EP2C35	✓	✓	✓	✓
EP2C50	✓	✓	✓	✓
EP2C70	✓	✓	✓	✓

[Table 2-5](#) describes the PLL features in Cyclone II devices.

Feature	Description
Clock multiplication and division	$m / (n \times \text{post-scale counter})$ m and post-scale counter values (C0 to C2) range from 1 to 32. n ranges from 1 to 4.
Phase shift	Cyclone II PLLs have an advanced clock shift capability that enables programmable phase shifts in increments of at least 45°. The finest resolution of phase shifting is determined by the voltage control oscillator (VCO) period divided by 8 (for example, 1/1000 MHz/8 = down to 125-ps increments).

Feature	Description
Programmable duty cycle	The programmable duty cycle allows PLLs to generate clock outputs with a variable duty cycle. This feature is supported on each PLL post-scale counter (C0-C2).
Number of internal clock outputs	The Cyclone II PLL has three outputs which can drive the global clock network. One of these outputs (C2) can also drive a dedicated PLL<#>_OUT pin (single ended or differential).
Number of external clock outputs	The C2 output drives a dedicated PLL<#>_OUT pin. If the C2 output is not used to drive an external clock output, it can be used to drive the internal global clock network. The C2 output can concurrently drive the external clock output and internal global clock network.
Manual clock switchover	The Cyclone II PLLs support manual switchover of the reference clock through internal logic. This enables a designer to switch between two reference input clocks during user mode for applications that may require clock redundancy or support for clocks with two different frequencies.
Programmable bandwidth	Cyclone II PLLs allow the designer to control the bandwidth over a finite range to customize the PLL characteristics for a particular application. Advanced control of the PLL bandwidth is provided through the programmable characteristics of the PLL loop, including loop filter and charge pump. The bandwidth range is determined after characterization.
Gated lock signal	The lock output indicates that there is a stable clock output signal in phase with the reference clock. Cyclone II PLLs include a programmable counter that holds the lock signal low for a user-selected number of input clock transitions, allowing the PLL to lock before enabling the locked signal. Either a gated locked signal or an ungated locked signal from the locked port can drive internal logic or an output pin.
Clock feedback modes	In zero delay buffer mode, the external clock output pin is phase-aligned with the clock input pin for zero delay. In normal mode, the PLL compensates for the internal global clock network delay from the input clock pin to the clock port of the IOE output registers or registers in the logic array. In no compensation mode, the PLL does not compensate for any clock networks.
Control signals	The <code>pllenable</code> signal enables and disables the PLLs. The <code>areset</code> signal resets/resynchronizes the inputs for each PLL. The <code>pfdena</code> signal controls the phase frequency detector (PFD) output with a programmable gate.

Figure 2–16 shows a block diagram of the Cyclone II PLL.

Figure 2–16. Cyclone II PLL *Note (1)*

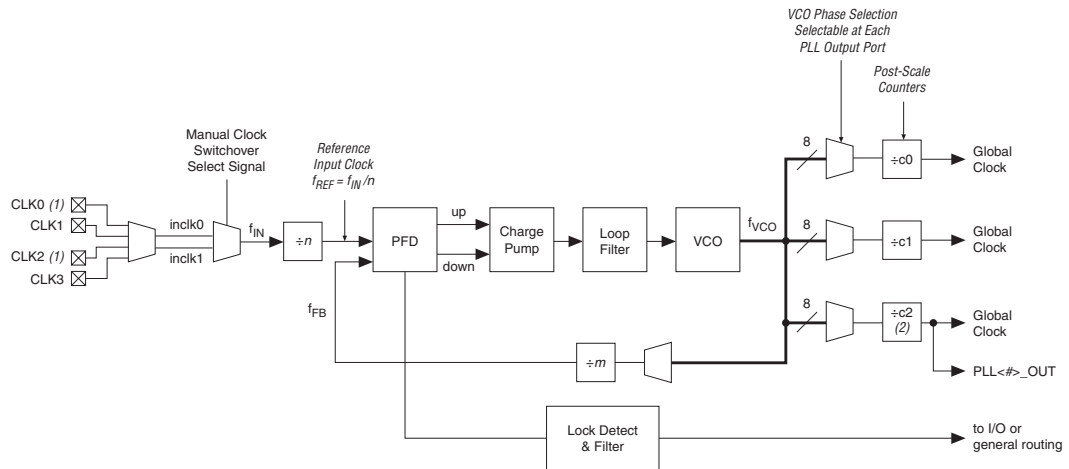

Notes to Figure 2–16:

- (1) This input can be single-ended or differential. If a designer is using a differential I/O standard, then two CLK pins are used. LVDS input is supported via the secondary function of the dedicated CLK pins. For example, the CLK0 pin's secondary function is LVDSCLK1p and the CLK1 pin's secondary function is LVDSCLK1n. If a differential I/O standard is assigned to the PLL clock input pin, the corresponding CLK (n) pin is also completely used. The Figure 2–16 shows the possible clock input connections (CLK0/CLK1) to PLL1.
- (2) This counter output is shared between a dedicated external clock output I/O and the global clock network.



For more information on Cyclone II PLLs, see the PLLs in the *Cyclone II Devices* chapter in Volume 1 of the *Cyclone II Device Handbook*.

Embedded Memory

The Cyclone II embedded memory consists of columns of M4K memory blocks. The M4K memory blocks include input registers that synchronize writes and output registers to pipeline designs and improve system performance. The output registers can be bypassed, but input registers cannot.

Each M4K block can implement various types of memory with or without parity, including true dual-port, simple dual-port, and single-port RAM, ROM, and first-in first-out (FIFO) buffers. The M4K blocks support the following features:

- 4,608 RAM bits
- 250-MHz performance
- True dual-port memory
- Simple dual-port memory
- Single-port memory
- Byte enable
- Parity bits
- Shift register
- FIFO buffer
- ROM
- Various clock modes
- Address clock enable

Table 2–6 shows the capacity and distribution of the M4K memory blocks in each Cyclone II device.

Device	M4K Columns	M4K Blocks	Total RAM Bits
EP2C5	2	26	119,808
EP2C8	2	36	165,888
EP2C20	2	52	239,616
EP2C35	3	105	483,840
EP2C50	3	129	594,432
EP2C70	5	250	1,152,000

Table 2–7 summarizes the features supported by the M4K memory.

Feature	Description
Maximum performance (1)	250 MHz
Total RAM bits per M4K block (including parity bits)	4,608

Table 2–7. M4K Memory Features (Part 2 of 2)

Feature	Description
Configurations supported	4K × 1 2K × 2 1K × 4 512 × 8 512 × 9 256 × 16 256 × 18 128 × 32 (not available in true dual-port mode) 128 × 36 (not available in true dual-port mode)
Parity bits	One parity bit for each byte. The parity bit, along with internal user logic, can implement parity checking for error detection to ensure data integrity.
Byte enable	M4K blocks support byte writes when the write port has a data width of 1, 2, 4, 8, 9, 16, 18, 32, or 36 bits. The byte enables allow the input data to be masked so the device can write to specific bytes. The unwritten bytes retain the previous written value.
Packed mode	Two single-port memory blocks can be packed into a single M4K block if each of the two independent block sizes are equal to or less than half of the M4K block size, and each of the single-port memory blocks is configured in single-clock mode.
Address clock enable	M4K blocks support address clock enable, which is used to hold the previous address value for as long as the signal is enabled. This feature is useful in handling misses in cache applications.
Memory initialization file (.mif)	When configured as RAM or ROM, the designer can use an initialization file to pre-load the memory contents.
Power-up condition	Outputs cleared
Register clears	Output registers only
Same-port read-during-write	New data available at positive clock edge
Mixed-port read-during-write	Old data available at positive clock edge

Note to Table 2–7:

(1) Maximum performance information is preliminary until device characterization.

Memory Modes

Table 2–8 summarizes the different memory modes supported by the M4K memory blocks.

Table 2–8. M4K Memory Modes	
Memory Mode	Description
Single-port memory	M4K blocks support single-port mode, used when simultaneous reads and writes are not required. Single-port memory supports non-simultaneous reads and writes.
Simple dual-port memory	Simple dual-port memory supports a simultaneous read and write.
Simple dual-port with mixed width	Simple dual-port memory mode with different read and write port widths.
True dual-port memory	True dual-port mode supports any combination of two-port operations: two reads, two writes, or one read and one write at two different clock frequencies.
True dual-port with mixed width	True dual-port mode with different read and write port widths.
Embedded shift register	M4K memory blocks are used to implement shift registers. Data is written into each address location at the falling edge of the clock and read from the address at the rising edge of the clock.
ROM	The M4K memory blocks support ROM mode. A MIF initializes the ROM contents of these blocks.
FIFO buffers	A single clock or dual clock FIFO may be implemented in the M4K blocks. Simultaneous read and write from an empty FIFO buffer is not supported.

Clock Modes

Table 2–9 summarizes the different clock modes supported by the M4K memory.

Clock Mode	Description
Independent	In this mode, a separate clock is available for each port (ports A and B). Clock A controls all registers on the port A side, while clock B controls all registers on the port B side.
Input/output	On each of the two ports, A or B, one clock controls all registers for inputs into the memory block: data input, <i>wren</i> , and address. The other clock controls the block's data output registers.
Read/write	Up to two clocks are available in this mode. The write clock controls the block's data inputs, <i>wraddress</i> , and <i>wren</i> . The read clock controls the data output, <i>rdaddress</i> , and <i>rden</i> .
Single	In this mode, a single clock, together with clock enable, is used to control all registers of the memory block. Asynchronous clear signals for the registers are not supported.

Table 2–10 shows which clock modes are supported by all M4K blocks when configured in the different memory modes.

Clocking Modes	True Dual-Port Mode	Simple Dual-Port Mode	Single-Port Mode
Independent	✓		
Input/output	✓	✓	✓
Read/write		✓	
Single clock	✓	✓	✓

M4K Routing Interface

The R4, C4, and direct link interconnects from adjacent LABs drive the M4K block local interconnect. The M4K blocks can communicate with LABs on either the left or right side through these row resources or with LAB columns on either the right or left with the column resources. Up to 16 direct link input connections to the M4K block are possible from the left adjacent LAB and another 16 possible from the right adjacent LAB. M4K block outputs can also connect to left and right LABs through each 16 direct link interconnects. Figure 2–17 shows the M4K block to logic array interface.

Figure 2–17. M4K RAM Block LAB Row Interface

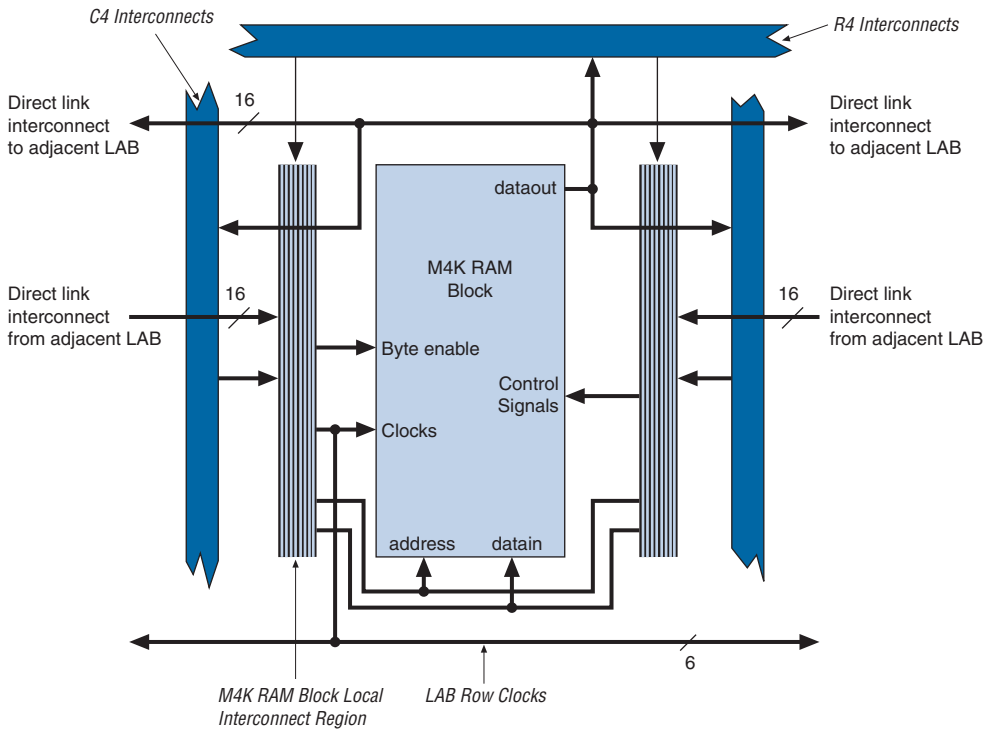

For more information on Cyclone II embedded memory, see the *Cyclone II Memory Blocks* chapter in Volume 1 of the *Cyclone II Device Handbook*.

Embedded Multipliers

Cyclone II devices have embedded multiplier blocks optimized for multiplier-intensive digital signal processing (DSP) functions, such as finite impulse response (FIR) filters, fast Fourier transform (FFT) functions, and discrete cosine transform (DCT) functions. Designers can use the embedded multiplier in one of two basic operational modes, depending on the application needs:

- One 18-bit multiplier
- Up to two independent 9-bit multipliers

Embedded multipliers can operate at up to 250 MHz (for the fastest speed grade) for 18×18 and 9×9 multiplications when using both input and output registers.

Each Cyclone II device has one to three columns of embedded multipliers that efficiently implement multiplication functions. An embedded multiplier spans the height of one LAB row. [Table 2–11](#) shows the number of embedded multipliers in each Cyclone II device and the multipliers that can be implemented.

Device	Embedded Multiplier Columns	Embedded Multipliers	9×9 Multipliers	18×18 Multipliers
EP2C5	1	13	26	13
EP2C8	1	18	36	18
EP2C20	1	26	52	26
EP2C35	1	35	70	35
EP2C50	2	86	172	86
EP2C70	3	150	300	150

Note to Table 2–11:

- (1) Each device has either the number of 9×9 -, or 18×18 -bit multipliers shown. The total number of multipliers for each device is not the sum of all the multipliers.

The embedded multiplier consists of the following elements:

- Multiplier block
- Input and output registers
- Input and output interfaces

[Figure 2–18](#) shows the multiplier block architecture.

Figure 2–18. Multiplier Block Architecture

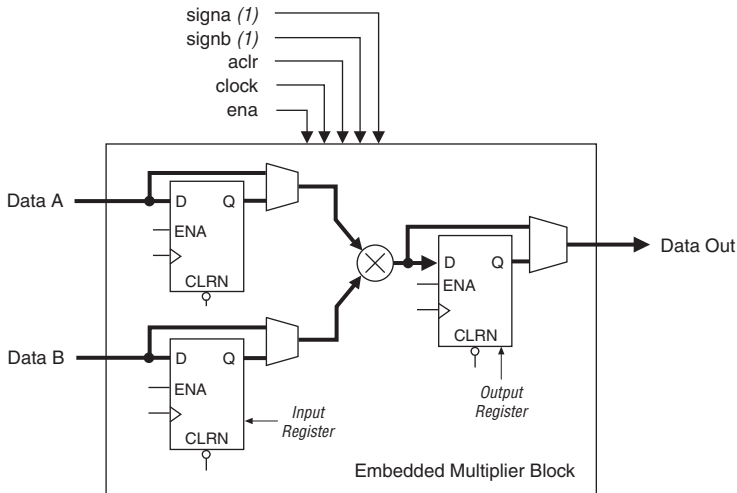

Note to Figure 2–18:

(1) If necessary, these signals can be registered once to match the data signal path.

Each multiplier operand can be a unique signed or unsigned number. Two signals, *signa* and *signb*, control the representation of each operand respectively. A logic 1 value on the *signa* signal indicates that data A is a signed number while a logic 0 value indicates an unsigned number. Table 2–12 shows the sign of the multiplication result for the various operand sign representations. The result of the multiplication is signed if any one of the operands is a signed value.

Data A (signa Value)	Data B (signb Value)	Result
Unsigned	Unsigned	Unsigned
Unsigned	Signed	Signed
Signed	Unsigned	Signed
Signed	Signed	Signed

There is only one `signa` and one `signb` signal for each dedicated multiplier. Therefore, all of the data A inputs feeding the same dedicated multiplier must have the same sign representation. Similarly, all of the data B inputs feeding the same dedicated multiplier must have the same sign representation. The `signa` and `signb` signals can be changed dynamically to modify the sign representation of the input operands at run time. The multiplier offers full precision regardless of the sign representation and can be registered using dedicated registers located at the input register stage.

Multiplier Modes

Table 2–13 summarizes the different modes that the embedded multipliers can operate in.

Multiplier Mode	Description
18-bit Multiplier	An embedded multiplier can be configured to support a single 18×18 multiplier for operand widths up to 18 bits. All 18-bit multiplier inputs and results can be registered independently. The multiplier operands can accept signed integers, unsigned integers, or a combination of both.
9-bit Multiplier	An embedded multiplier can be configured to support two 9×9 independent multipliers for operand widths up to 9-bits. Both 9-bit multiplier inputs and results can be registered independently. The multiplier operands can accept signed integers, unsigned integers or a combination of both. There is only one <code>signa</code> signal to control the sign representation of both data A inputs and one <code>signb</code> signal to control the sign representation of both data B inputs of the 9-bit multipliers within the same dedicated multiplier.

Embedded Multiplier Routing Interface

The R4, C4, and direct link interconnects from adjacent LABs drive the embedded multiplier row interface interconnect. The embedded multipliers can communicate with LABs on either the left or right side through these row resources or with LAB columns on either the right or left with the column resources. Up to 16 direct link input connections to the embedded multiplier are possible from the left adjacent LABs and another 16 possible from the right adjacent LAB. Embedded multiplier

outputs can also connect to left and right LABs through 18 direct link interconnects each. Figure 2–19 shows the embedded multiplier to logic array interface.

Figure 2–19. Embedded Multiplier LAB Row Interface

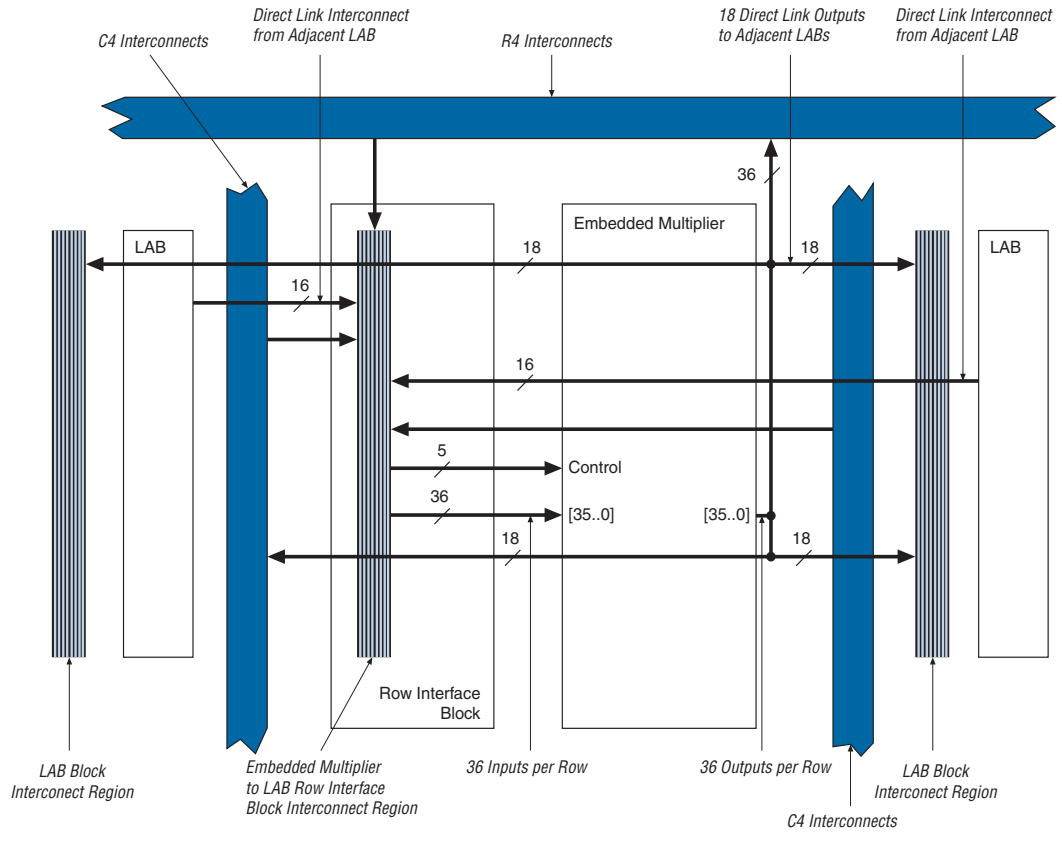

There are five dynamic control input signals that feed the embedded multiplier: `signa`, `signb`, `clk`, `clkena`, and `aclr`. `signa` and `signb` can be registered to match the data signal input path. The same `clk`, `clkena`, and `aclr` signals feed all registers within a single embedded multiplier.



For more information on Cyclone II embedded multipliers, see the *Embedded Multipliers in Cyclone II Devices* chapter.

I/O Structure & Features

IOEs support many features, including:

- Differential and single-ended I/O standards
- 3.3-V, 64- and 32-bit, 66- and 33-MHz PCI compliance
- Joint Test Action Group (JTAG) boundary-scan test (BST) support
- Output drive strength control
- Weak pull-up resistors during configuration
- Tri-state buffers
- Bus-hold circuitry
- Programmable pull-up resistors in user mode
- Programmable input and output delays
- Open-drain outputs
- DQ and DQS I/O pins
- V_{REF} pins

Cyclone II device IOEs contain a bidirectional I/O buffer and three registers for complete embedded bidirectional single data rate transfer. [Figure 2–20](#) shows the Cyclone II IOE structure. The IOE contains one input register, one output register, and one output enable register. The designer can use the input registers for fast setup times and output registers for fast clock-to-output times. Additionally, the designer can use the output enable (OE) register for fast clock-to-output enable timing. The Quartus II software automatically duplicates a single OE register that controls multiple output or bidirectional pins. Designers can use IOEs as input, output, or bidirectional pins.

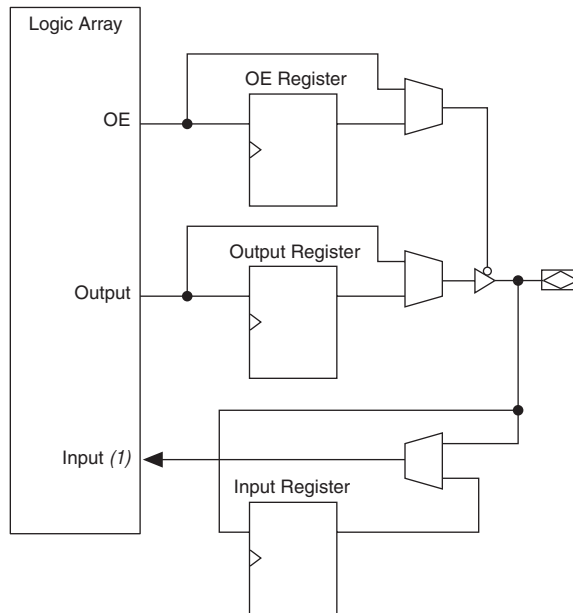
Figure 2–20. Cyclone II IOE Structure**Note to Figure 2–20:**

- (1) There are two paths available for combinatorial or registered inputs to the logic array. Each path contains a unique programmable delay chain.

The IOEs are located in I/O blocks around the periphery of the Cyclone II device. There are up to five IOEs per row I/O block and up to four IOEs per column I/O block (column I/O blocks span two columns). The row I/O blocks drive row, column (only C4 interconnects), or direct link interconnects. The column I/O blocks drive column interconnects.

Figure 2–21 shows how a row I/O block connects to the logic array.

Figure 2–22 shows how a column I/O block connects to the logic array.

Figure 2–21. Row I/O Block Connection to the Interconnect

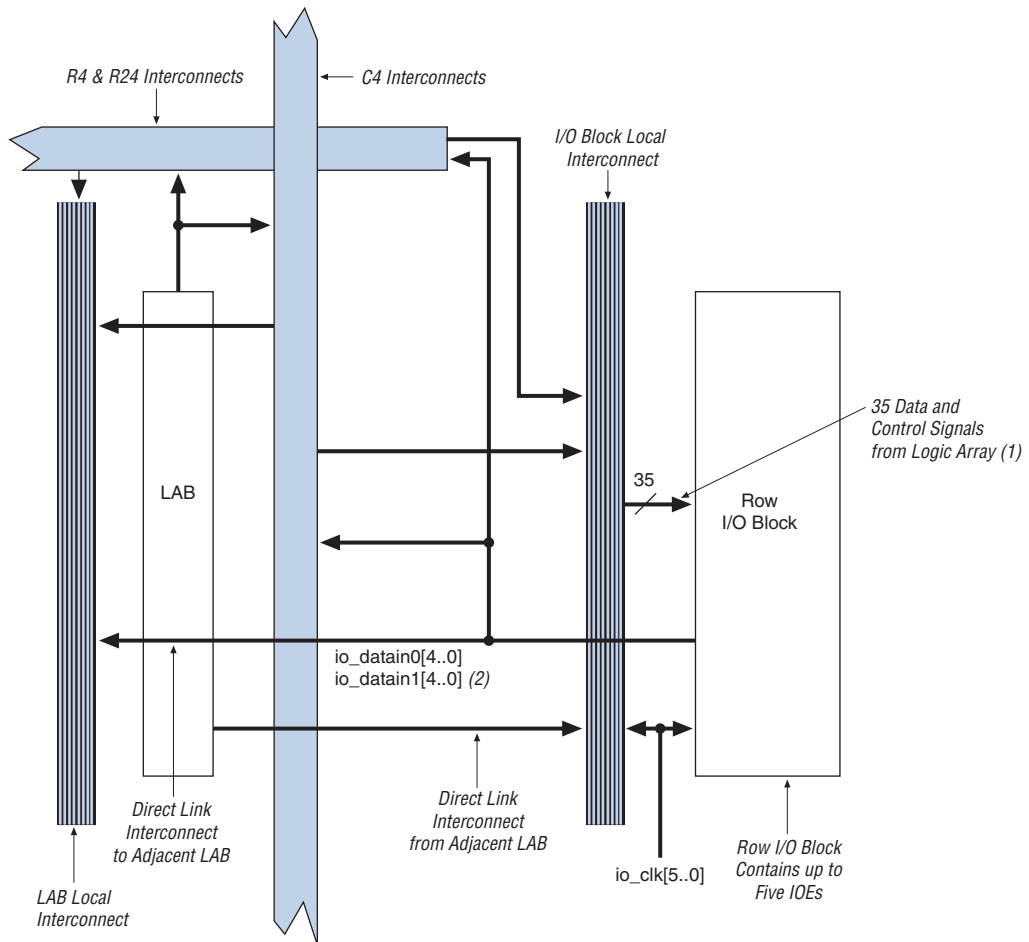
**Notes to Figure 2–21:**

- (1) The 35 data and control signals consist of five data out lines, $io_dataout[4..0]$, five output enables, $io_coe[4..0]$, five input clock enables, $io_cce_in[4..0]$, five output clock enables, $io_cce_out[4..0]$, five clocks, $io_cclk[4..0]$, five asynchronous clear signals, $io_caclr[4..0]$, and five synchronous clear signals, $io_csclr[4..0]$.
- (2) Each of the five IOEs in the row I/O block can have two io_datain input (combinatorial or registered) inputs.

Figure 2–22. Column I/O Block Connection to the Interconnect

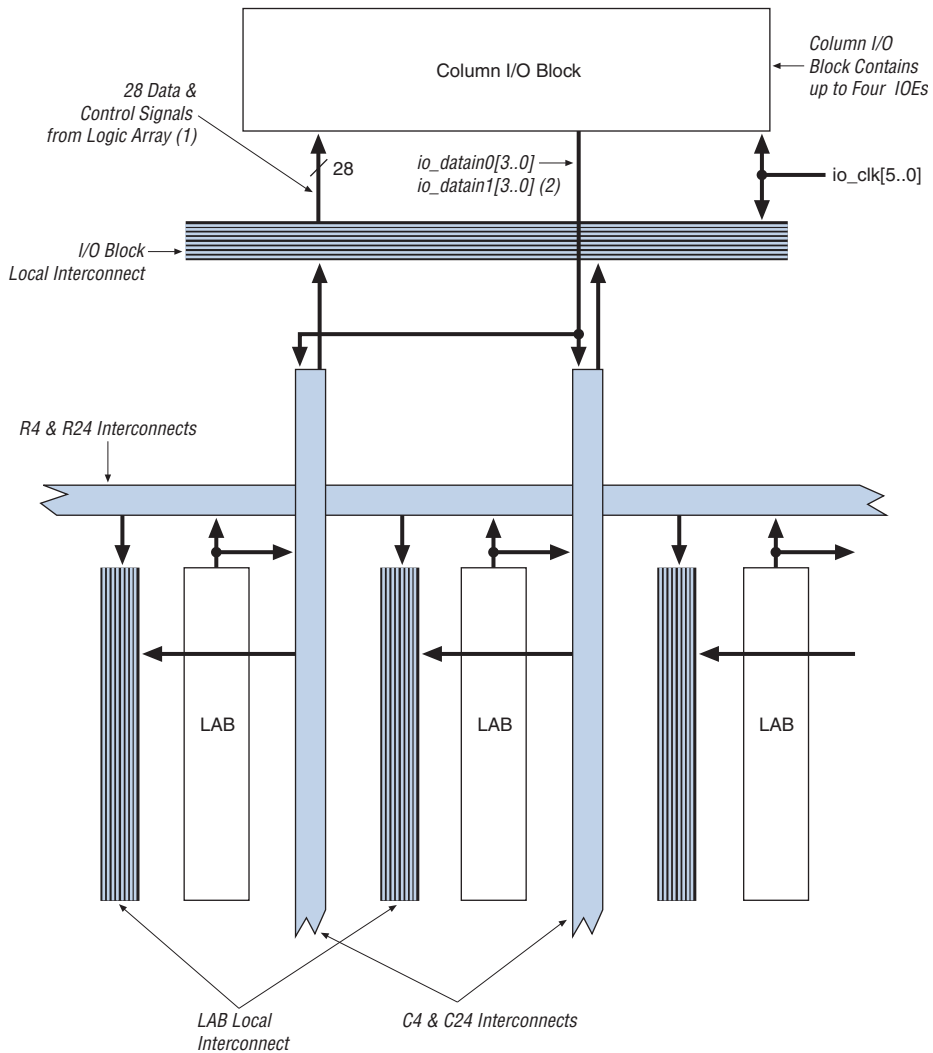
**Notes to Figure 2–22:**

- (1) The 28 data and control signals consist of four data out lines, `io_dataout[3..0]`, four output enables, `io_coe[3..0]`, four input clock enables, `io_cce_in[3..0]`, four output clock enables, `io_cce_out[3..0]`, four clocks, `io_clk[3..0]`, four asynchronous clear signals, `io_caclr[3..0]`, and four synchronous clear signals, `io_csclr[3..0]`.
- (2) Each of the four IOEs in the column I/O block can have two `io_datain` input (combinatorial or registered) inputs.

The pin's data in signals can drive the logic array. The logic array drives the control and data signals, providing a flexible routing resource. The row or column IOE clocks, `io_clk[5..0]`, provide a dedicated routing resource for low-skew, high-speed clocks. The global clock network generates the IOE clocks that feed the row or column I/O regions (see "Global Clock Network & Phase-Locked Loops" on page 2-16). Figure 2-23 illustrates the signal paths through the I/O block.

Figure 2-23. Signal Path through the I/O Block

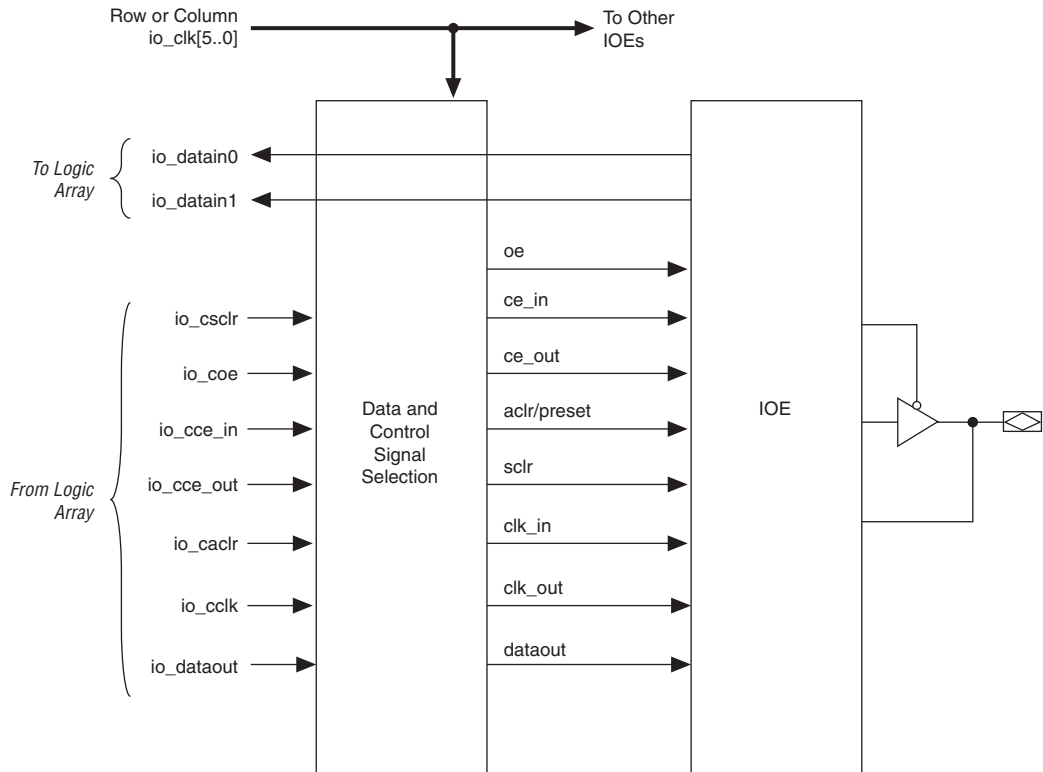

Each IOE contains its own control signal selection for the following control signals: `oe`, `ce_in`, `ce_out`, `aclr/preset`, `sclr/preset`, `clk_in`, and `clk_out`. Figure 2-24 illustrates the control signal selection.

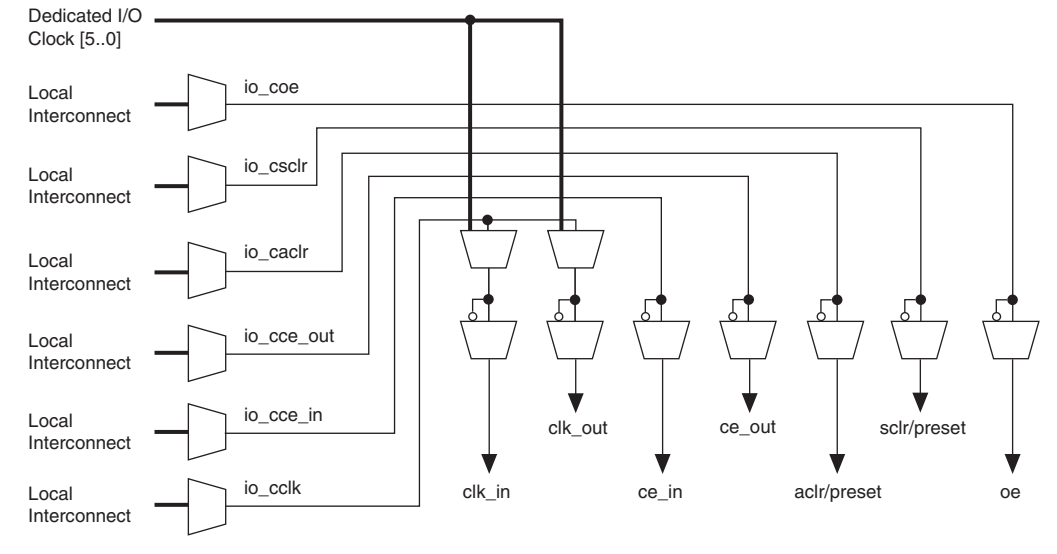
Figure 2–24. Control Signal Selection per IOE

In normal bidirectional operation, the designer can use the input register for input data requiring fast setup times. The input register can have its own clock input and clock enable separate from the OE and output registers. The designer can use the output register for data requiring fast clock-to-output performance. The OE register is available for fast clock-to-output enable timing. The OE and output register share the same clock source and the same clock enable source from the local interconnect in the associated LAB, dedicated I/O clocks, or the column and row interconnects. All registers share sclr and aclr, but each register can individually disable sclr and aclr. [Figure 2–25](#) shows the IOE in bidirectional configuration.

Figure 2–25. Cyclone II IOE in Bidirectional I/O Configuration

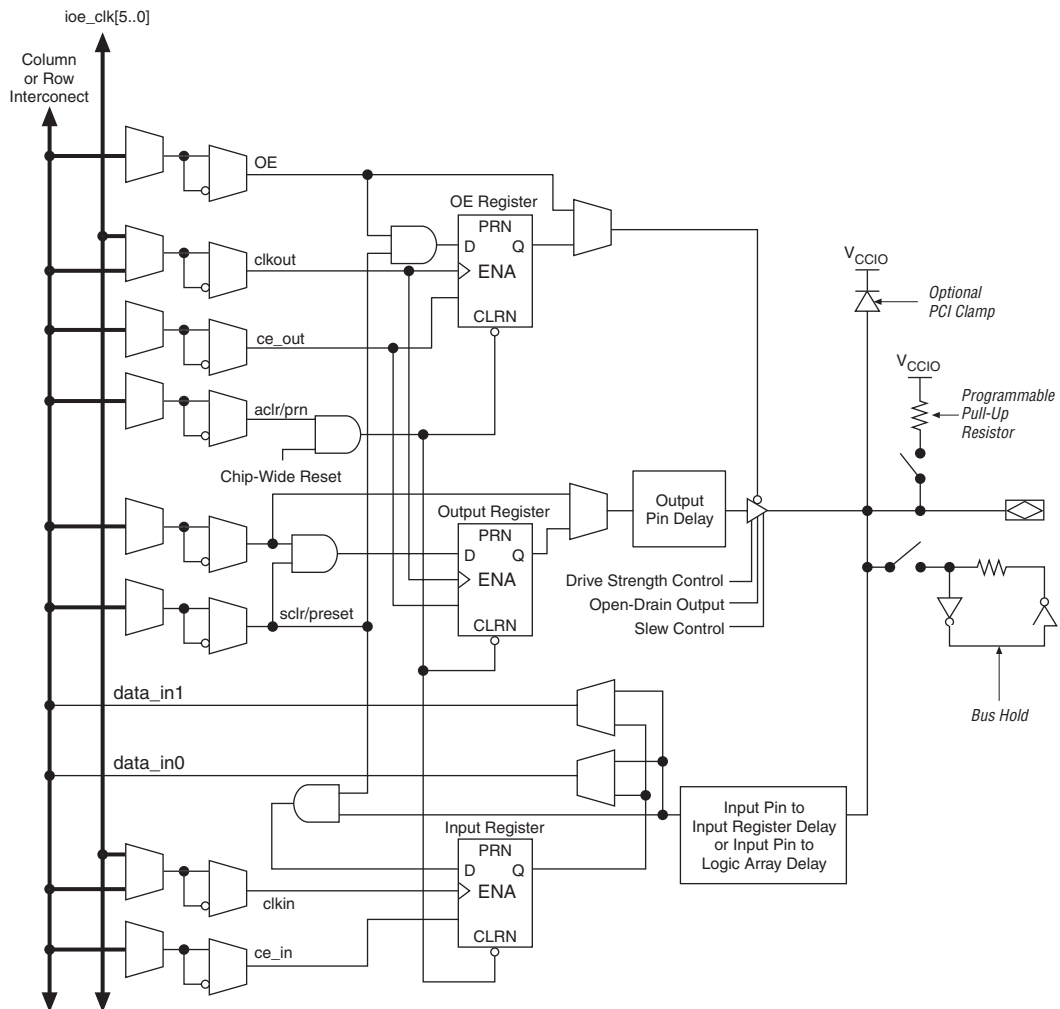

The Cyclone II device IOE includes programmable delays to ensure zero hold times, minimize setup times, or increase clock to output times.

A path in which a pin directly drives a register may require a programmable delay to ensure zero hold time, whereas a path in which a pin drives a register through combinatorial logic may not require the delay. Programmable delays decrease input-pin-to-logic-array and IOE input register delays. The Quartus II Compiler can program these delays to automatically minimize setup time while providing a zero hold time.

Programmable delays can increase the register-to-pin delays for output registers. Table 2–14 shows the programmable delays for Cyclone II devices.

Programmable Delays	Quartus II Logic Option
Input pin to logic array delay	Input delay from pin to internal cells
Input pin to input register delay	Input delay from pin to input register
Output pin delay	Delay from output register to output pin

There are two paths in the IOE for an input to reach the logic array. Each of the two paths can have a different delay. This allows the designer to adjust delays from the pin to internal LE registers that reside in two different areas of the device. The designer sets the two combinatorial input delays by selecting different delays for two different paths under the **Input delay from pin to internal cells logic** option in the Quartus II software. However, if the pin uses the input register, one of delays will be disregarded since the IOE only has two paths to internal logic. If the input register is used, the IOE uses one input path. The other input path is then available for the combinatorial path, and only one input delay assignment is applied.

The IOE registers in each I/O block share the same source for clear or preset. The designer can program preset or clear for each individual IOE, but both features cannot be used simultaneously. The designer can also program the registers to power up high or low after configuration is complete. If programmed to power up low, an asynchronous clear can control the registers. If programmed to power up high, an asynchronous preset can control the registers. This feature prevents the inadvertent activation of another device's active-low input upon power up. If one register in an IOE uses a preset or clear signal then all registers in the IOE must use that same signal if they require preset or clear. Additionally a synchronous reset signal is available to the designer for the IOE registers.

External Memory Interfacing

Cyclone II devices support a broad range of external memory interfaces such as SDR SDRAM, DDR SDRAM, DDR2 SDRAM, and QDR II SRAM external memories. Cyclone II devices feature dedicated high-speed interfaces that transfer data between external memory devices at up to 167 MHz/333 Mbps for DDR and DDR2 SDRAM devices and 167 MHz/667 Mbps for QDR II SRAM devices. The programmable DQS delay chain allows designers to fine tune the phase shift for the input clocks or strobes to properly align clock edges as needed to capture data.

In Cyclone II devices, all the I/O banks support SDR and DDR SDRAM memory up to 167 MHz/333 Mbps. All I/O banks support DQS signals with the DQ bus modes of $\times 8/\times 9$, or $\times 16/\times 18$. Table 2–15 shows the external memory interfaces supported in Cyclone II devices.

Memory Standard	I/O Standard	Maximum Bus Width	Maximum Clock Rate Supported (MHz)	Maximum Data Rate Supported (Mbps)
SDR SDRAM	LVTTTL (2)	72	167	167
DDR SDRAM	SSTL-2 class I (2)	72	167	333 (1)
	SSTL-2 class II (2)	72	133	267 (1)
DDR2 SDRAM	SSTL-18 class I (2)	72	167	333 (1)
	SSTL-18 class II (3)	72	125	250 (1)
QDR II SRAM (4)	1.8-V HSTL class I (2)	36	167	668 (1)
	1.8-V HSTL class II (3)	36	100	400 (1)

Notes to Table 2–15:

- (1) The data rate is for designs using the Clock Delay Control circuitry.
- (2) The I/O standards are supported on all the I/O banks of the Cyclone II device.
- (3) The I/O standards are supported only on the I/O banks on the top and bottom of the Cyclone II device.
- (4) For maximum performance, Altera recommends using the 1.8-V HSTL I/O standard because of higher I/O drive strength. QDR II SRAM devices also support the 1.5-V HSTL I/O standard.

Cyclone II devices use data (DQ), data strobe (DQS), and clock pins to interface with external memory. Figure 2–26 shows the DQ and DQS pins in the $\times 8/\times 9$ mode.

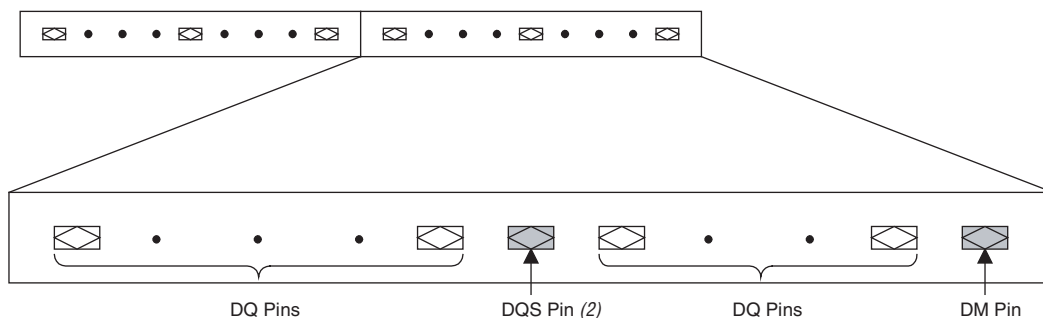
Figure 2–26. Cyclone II Device DQ & DQS Groups in $\times 8/\times 9$ Mode *Notes (1), (2)***Notes to Figure 2–26:**

- (1) Each DQ group consists of a DQS pin, DM pin, and up to nine DQ pins.
- (2) This is an idealized pin layout. For actual pin layout, refer to the pin table.

Cyclone II devices support the data strobe or read clock signal (DQS) used in DDR and DDR2 SDRAM. Cyclone II devices can use either bidirectional data strobes or unidirectional read clocks. The dedicated external memory interface in Cyclone II devices also includes programmable delay circuitry that can shift the incoming DQS signals to center align the DQS signals within the data window.

The DQS signal is usually associated with a group of data (DQ) pins. The phase-shifted DQS signals drive the global clock network, which is used to clock the DQ signals on internal LE registers.

Table 2–16 shows the number of DQ pin groups per device.

Table 2–16. Cyclone II DQS & DQ Bus Mode Support (Part 1 of 2) *Note (1)*

Device	Package	Number of $\times 8$ Groups	Number of $\times 9$ Groups	Number of $\times 16$ Groups	Number of $\times 18$ Groups
EP2C5	144-pin TQFP (2)	3	3	0	0
	208-pin PQFP (2)	7	4	3	3
EP2C8	144-pin TQFP	3	3	0	0
	208-pin PQFP	7	4	3	3
	256-pin FineLine BGA	8	4	4	4
EP2C20	256-pin FineLine BGA	8	4	4	4
	484-pin FineLine BGA	16	8	8	8
EP2C35	484-pin FineLine BGA	16	8	8	8
	672-pin FineLine BGA	16	8	8	8

Table 2–16. Cyclone II DQS & DQ Bus Mode Support (Part 2 of 2) *Note (1)*

Device	Package	Number of ×8 Groups	Number of ×9 Groups	Number of ×16 Groups	Number of ×18 Groups
EP2C50	484-pin FineLine BGA	16	8	8	8
	672-pin FineLine BGA	16	8	8	8
EP2C70	672-pin FineLine BGA	16	8	8	8
	896-pin FineLine BGA	16	8	8	8

Notes to Table 2–16:

- (1) Numbers are preliminary until the devices are available.
- (2) EP2C5 and EP2C8 devices in the 144-pin TQFP package do not have any DQ pin groups in I/O bank 1.

Designers can use any of the DQ pins for the parity pins in Cyclone II devices. The Cyclone II device family supports parity in the ×8/×9, and ×16/×18 mode. There is one parity bit available per eight bits of data pins.

The data mask, DM, pins are required when writing to DDR SDRAM and DDR2 SDRAM devices. A low signal on the DM pin indicates that the write is valid. If the DM signal is high, the memory masks the DQ signals. In Cyclone II devices, the DM pins are assigned and are the preferred pins. Each group of DQS and DQ signals requires a DM pin.

When using the Cyclone II I/O banks to interface with the DDR memory, at least one PLL with two clock outputs is needed to generate the system and write clock. The system clock is used to clock the DQS write signals, commands, and addresses. The write clock is shifted by -90° from the system clock and is used to clock the DQ signals during writes.

Figure 2–27 illustrates DDR SDRAM interfacing from the I/O through the dedicated circuitry to the logic array.

Figure 2-27. DDR SDRAM Interfacing

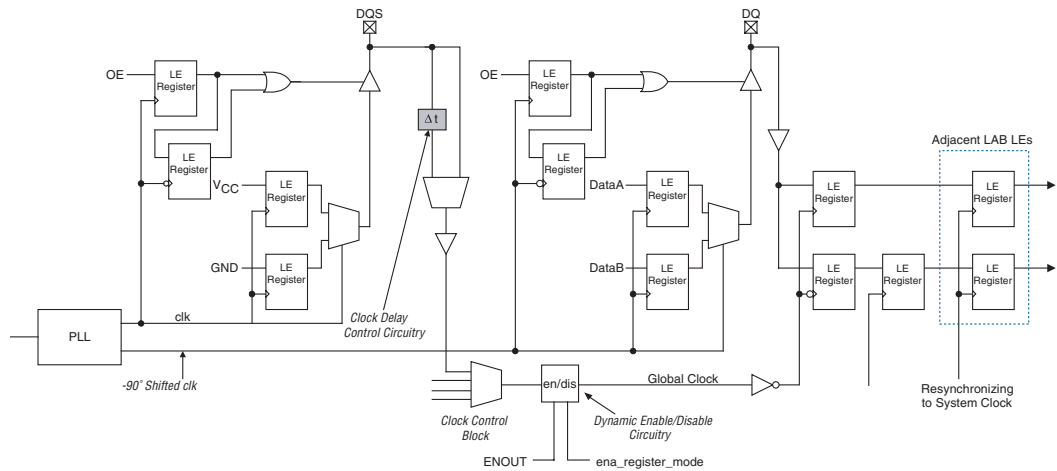

For more information on Cyclone II external memory interfaces, see the *External Memory Interfaces* chapter in Volume 1 of the *Cyclone II Device Handbook*.

Programmable Drive Strength

The output buffer for each Cyclone II device I/O pin has a programmable drive strength control for certain I/O standards. The LVTTTL, LVCMOS, SSTL-2 class I and II, SSTL-18 class I and II, HSTL-18 class I and II, and HSTL-1.5 class I and II standards have several levels of drive strength that the designer can control. Using minimum settings provides signal slew rate control to reduce system noise and signal overshoot. [Table 2-17](#) shows the possible settings for the I/O standards with drive strength control.

I/O Standard	I_{OH}/I_{OL} Current Strength Setting (mA)	
	Top & Bottom I/O Pins	Side I/O Pins
LVTTTL (3.3 V)	4	4
	8	8
	12	12
	16	16
	20	20
	24	24
LVCMOS (3.3 V)	4	4
	8	8
	12	12
	16	
	20	
	24	
LVTTTL/LVCMOS (2.5 V)	4	4
	8	8
	12	
	16	
LVTTTL/LVCMOS (1.8 V)	2	2
	4	4
	6	6
	8	8
	10	10
	12	12

I/O Standard	I _{OH} /I _{OL} Current Strength Setting (mA)	
	Top & Bottom I/O Pins	Side I/O Pins
LVCMOS (1.5 V)	2	2
	4	4
	6	6
	8	
SSTL-2 class I	8	8
	12	12
SSTL-2 class II	16	16
	20	
	24	
SSTL-18 class I	4	4
	6	6
	8	8
	10	10
	12	
SSTL-18 class II	8	
	16	
	18	
HSTL-18 class I	4	4
	6	6
	8	8
	10	10
	12	12
HSTL-18 class II	16	
	18	
	20	
HSTL-15 class I	4	4
	6	6
	8	8
	10	
	12	
HSTL-15 class II	16	

Open-Drain Output

Cyclone II devices provide an optional open-drain (equivalent to an open-collector) output for each I/O pin. This open-drain output enables the device to provide system-level control signals (that is, interrupt and write-enable signals) that can be asserted by any of several devices.

Slew Rate Control

Slew rate control is performed by using programmable output drive strength.

Bus Hold

Each Cyclone II device user I/O pin provides an optional bus-hold feature. The bus-hold circuitry can hold the signal on an I/O pin at its last-driven state. Since the bus-hold feature holds the last-driven state of the pin until the next input signal is present, an external pull-up or pull-down resistor is not necessary to hold a signal level when the bus is tri-stated.

The bus-hold circuitry also pulls undriven pins away from the input threshold voltage where noise can cause unintended high-frequency switching. The designer can select this feature individually for each I/O pin. The bus-hold output will drive no higher than V_{CCIO} to prevent overdriving signals.



If the bus-hold feature is enabled, the device cannot use the programmable pull-up option. Disable the bus-hold feature when the I/O pin is configured for differential signals. Bus hold circuitry is not available on the dedicated clock pins.

The bus-hold circuitry is only active after configuration. When going into user mode, the bus-hold circuit captures the value on the pin present at the end of configuration.

The bus-hold circuitry uses a resistor with a nominal resistance (R_{BH}) of approximately 7 k Ω to pull the signal level to the last-driven state. Refer to the *DC Characteristics & Timing Specifications* chapter in Volume 1 of the *Cyclone II Device Handbook* for the specific sustaining current for each V_{CCIO} voltage level driven through the resistor and overdrive current used to identify the next driven input level.

Programmable Pull-Up Resistor

Each Cyclone II device I/O pin provides an optional programmable pull-up resistor during user mode. If the designer enables this feature for an I/O pin, the pull-up resistor (typically 25 k Ω) holds the output to the V_{CCIO} level of the output pin's bank.



If the programmable pull-up is enabled, the device cannot use the bus-hold feature. The programmable pull-up resistors are not supported on the dedicated configuration, JTAG, and dedicated clock pins.

Advanced I/O Standard Support

Table 2–18 shows the I/O standards supported by Cyclone II devices and which I/O pins support them.

I/O Standard	Type	V_{CCIO} Level		Top & Bottom I/O Pins		Side I/O Pins		
		Input	Output	CLK, DQS	User I/O Pins	CLK, DQS	PLL_OUT	User I/O Pins
3.3-V LVTTTL and LVCMOS	Single ended	3.3 V/ 2.5 V	3.3 V	✓	✓	✓	✓	✓
2.5-V LVTTTL and LVCMOS	Single ended	3.3 V/ 2.5 V	2.5 V	✓	✓	✓	✓	✓
1.8-V LVTTTL and LVCMOS	Single ended	1.8 V/ 1.5 V	1.8 V	✓	✓	✓	✓	✓
1.5-V LVCMOS	Single ended	1.8 V/ 1.5 V	1.5 V	✓	✓	✓	✓	✓
SSTL-2 class I	Voltage referenced	2.5 V	2.5 V	✓	✓	✓	✓	✓
SSTL-2 class II	Voltage referenced	2.5 V	2.5 V	✓	✓	✓	✓	✓
SSTL-18 class I	Voltage referenced	1.8 V	1.8 V	✓	✓	✓	✓	✓
SSTL-18 class II	Voltage referenced	1.8 V	1.8 V	✓	✓	(1)	(1)	(1)
HSTL-18 class I	Voltage referenced	1.8 V	1.8 V	✓	✓	✓	✓	✓
HSTL-18 class II	Voltage referenced	1.8 V	1.8 V	✓	✓	(1)	(1)	(1)

Table 2–18. Cyclone II Supported I/O Standards & Constraints (Part 2 of 2)

I/O Standard	Type	V _{CCIO} Level		Top & Bottom I/O Pins		Side I/O Pins		
		Input	Output	CLK, DQS	User I/O Pins	CLK, DQS	PLL_OUT	User I/O Pins
HSTL-15 class I	Voltage referenced	1.5 V	1.5 V	✓	✓	✓	✓	✓
HSTL-15 class II	Voltage referenced	1.5 V	1.5 V	✓	✓	(1)	(1)	(1)
PCI and PCI-X (2)	Single ended	3.3 V	3.3 V			✓	✓	✓
Differential SSTL-2 class I or class II	Pseudo differential (3)	(4)	2.5 V				✓	
		2.5 V	(4)	✓	(5)	✓	(5)	
Differential SSTL-18 class I or class II	Pseudo differential (3)	(4)	1.8 V				✓ (6)	
		1.8 V	(4)	✓	(5)	✓	(5)	
Differential HSTL-15 class I or class II	Pseudo differential (3)	(4)	1.5 V				✓ (6)	
		1.5 V	(4)	✓	(5)	✓	(5)	
Differential HSTL-18 class I or class II	Pseudo differential (3)	(4)	1.8 V				✓ (6)	
		1.8 V	(4)	✓	(5)	✓	(5)	
LVDS	Differential	2.5 V	2.5 V	✓	✓	✓	✓	✓
RSDS and mini-LVDS (7)	Differential	(4)	2.5 V		✓		✓	✓
LVPECL (8)	Differential	3.3 V/ 2.5 V/ 1.8 V/ 1.5 V	(4)	✓		✓		

Notes to Table 2–18:

- (1) These pins support SSTL-18 class II and 1.8- and 1.5-V HSTL class II inputs.
- (2) PCI-X does not meet the IV curve requirement at the linear region. PCI-clamp diode is not available on top and bottom I/O pins.
- (3) Pseudo-differential HSTL and SSTL outputs use two single-ended outputs with the second output programmed as inverted. Pseudo-differential HSTL and SSTL inputs treat differential inputs as two single-ended HSTL and SSTL inputs and only decode one of them.
- (4) This I/O standard is not supported on these I/O pins.
- (5) This I/O standard is only supported on the dedicated clock pins.
- (6) PLL_OUT does not support differential SSTL-18 class II and differential 1.8 and 1.5-V HSTL class II.
- (7) mini-LVDS and RSDS are only supported on output pins.
- (8) LVPECL is only supported on clock inputs.



For more information on Cyclone II supported I/O standards, see the *Selectable I/O Standards in Cyclone II Devices* chapter in Volume 1 of the *Cyclone II Device Handbook*.

High-Speed Differential Interfaces

Cyclone II devices can transmit and receive data through LVDS signals at a data rate of up to 622 Mbps and 805 Mbps, respectively. For the LVDS transmitter and receiver, the Cyclone II device's input and output pins support serialization and deserialization through internal logic.

The reduced swing differential signaling (RSDS) and mini-LVDS standards are derivatives of the LVDS standard. The RSDS and mini-LVDS I/O standards are similar in electrical characteristics to LVDS, but have a smaller voltage swing and therefore provide increased power benefits and reduced electromagnetic interference (EMI). Cyclone II devices support the RSDS and mini-LVDS I/O standards at data rates up to 170 Mbps at the transmitter. For RSDS and mini-LVDS, the maximum internal clock frequency is 85 MHz.

A subset of pins in each I/O bank (on both rows and columns) support the high-speed I/O interface. The dual-purpose LVDS pins require an external-resistor network at the transmitter channels in addition to 100- Ω termination resistors on receiver channels. These pins do not contain dedicated serialization or deserialization circuitry. Therefore, internal logic performs serialization and deserialization functions.

Cyclone II pin tables list the pins that support the high-speed I/O interface. The number of LVDS channels supported in each device family member is listed in [Table 2-19](#).

Device	Pin Count	Number of LVDS Channels (1)
EP2C5	144	33 (35)
	208	58 (60)
EP2C8	144	31 (33)
	208	55 (57)
	256	77 (79)
EP2C20	256	56 (60)
	484	132 (136)
EP2C35	484	135 (139)
	672	205 (209)

Table 2–19. Cyclone II Device LVDS Channels (Part 2 of 2)

Device	Pin Count	Number of LVDS Channels ⁽¹⁾
EP2C50	484	122 (126)
	672	193 (197)
EP2C70	672	164 (168)
	896	261 (265)

Note to Table 2–19:

- (1) The first number represents the number of bidirectional I/O pins which can be used as inputs or outputs. The number in parenthesis includes dedicated clock input pin pairs which can only be used as inputs.

You can use I/O pins and internal logic to implement a high-speed I/O receiver and transmitter in Cyclone II devices. Cyclone II devices do not contain dedicated serialization or deserialization circuitry. Therefore, shift registers, internal PLLs, and IOEs are used to perform serial-to-parallel conversions on incoming data and parallel-to-serial conversion on outgoing data.

The maximum internal clock frequency for a receiver is 402.5 MHz. The maximum internal clock frequency for a transmitter is 311 MHz. The maximum data rate of 805 Mbps is only achieved when DDIO registers are used. The LVDS standard does not require an input reference voltage, but it does require a 100- Ω termination resistor between the two signals at the input buffer. An external resistor network is required on the transmitter side.



For more information on Cyclone II differential I/O interfaces, see the *High-Speed Differential Interfaces in Cyclone II Devices* chapter in Volume 1 of the *Cyclone II Device Handbook*.

Series On-Chip Termination

On-chip termination helps to prevent reflections and maintain signal integrity. This also minimizes the need for external resistors in high pin count ball grid array (BGA) packages. Cyclone II devices provide I/O driver on-chip impedance matching and on-chip series termination for single-ended outputs and bidirectional pins.

Cyclone II devices support driver impedance matching to the impedance of the transmission line, typically 25 or 50 Ω . When used with the output drivers, on-chip termination sets the output driver impedance to 25 or 50 Ω . Cyclone II devices also support I/O driver series termination ($R_S = 50 \Omega$) for SSTL-2 and SSTL-18. Table 2–20 lists the I/O standards that support impedance matching and series termination.

I/O Standards	Target R_S (Ω)	V_{CCIO} (V)
3.3-V LVTTTL and LVCMOS	25 (2)	3.3
2.5-V LVTTTL and LVCMOS	50 (2)	2.5
1.8-V LVTTTL and LVCMOS	50 (2)	1.8
SSTL-2 class I	50 (2)	2.5
SSTL-18 class I	50 (2)	1.8

Notes to Table 2–20:

- (1) Supported conditions are junction temperature (T_j) = 0° to 85° C and $V_{CCIO} = V_{CCIO} \pm 50$ mV.
- (2) These R_S values are nominal values. Actual impedance will vary across process, voltage, and temperature conditions. Tolerance is pending characterization.



The recommended frequency range of operation is pending silicon characterization.

On-chip series termination can be supported on any I/O bank. V_{CCIO} and V_{REF} must be compatible for all I/O pins in order to enable on-chip series termination in a given I/O bank. I/O standards that support different R_S values can reside in the same I/O bank as long as their V_{CCIO} and V_{REF} are not conflicting.



When using on-chip series termination, programmable drive strength is not available.

Impedance matching is implemented using the capabilities of the output driver and is subject to a certain degree of variation, depending on the process, voltage and temperature. The actual tolerance is pending silicon characterization.

I/O Banks

The I/O pins on Cyclone II devices are grouped together into I/O banks and each bank has a separate power bus. EP2C5 and EP2C8 devices have four I/O banks (see [Figure 2–28](#)), while EP2C20, EP2C35, EP2C50, and EP2C70 devices have eight I/O banks (see [Figure 2–29](#)). Each device I/O pin is associated with one I/O bank. To accommodate voltage-referenced I/O standards, each Cyclone II I/O bank has a VREF bus. Each bank in EP2C5, EP2C8, EP2C20, EP2C35, and EP2C50 devices supports two VREF pins and each bank of EP2C70 supports three VREF pins. When using the VREF pins, each VREF pin must be properly connected to the appropriate voltage level. In the event these pins are not used as VREF pins, they may be used as regular I/O pins.

The top and bottom I/O banks (banks 2 and 4 in EP2C5 and EP2C8 devices and banks 3, 4, 7, and 8 in EP2C20, EP2C35, EP2C50, and EP2C70 devices) support all I/O standards listed in [Table 2–18](#), except the PCI/PCI-X I/O standards. The left and right side I/O banks (banks 1 and 3 in EP2C5 and EP2C8 devices and banks 1, 2, 5, and 6 in EP2C20, EP2C35, EP2C50, and EP2C70 devices) support I/O standards listed in [Table 2–18](#), except SSTL-18 class II, HSTL-18 class II, and HSTL-15 class II I/O standards. See [Table 2–18](#) for a complete list of supported I/O standards.

The top and bottom I/O banks (banks 2 and 4 in EP2C5 and EP2C8 devices and banks 3, 4, 7, and 8 in EP2C20, EP2C35, EP2C50, and EP2C70 devices) support DDR2 memory up to 167 MHz/333 Mbps and QDR memory up to 167 MHz/668 Mbps. The left and right side I/O banks (1 and 3 of EP2C5 and EP2C8 devices and 1, 2, 5, and 6 of EP2C20, EP2C35, EP2C50, and EP2C70 devices) only support SDR and DDR SDRAM interfaces. All the I/O banks of the Cyclone II devices support SDR memory up to 167 MHz/167 Mbps and DDR memory up to 167 MHz/333 Mbps.

Figure 2–28. EP2C5 & EP2C8 I/O Banks *Notes (1), (2)*

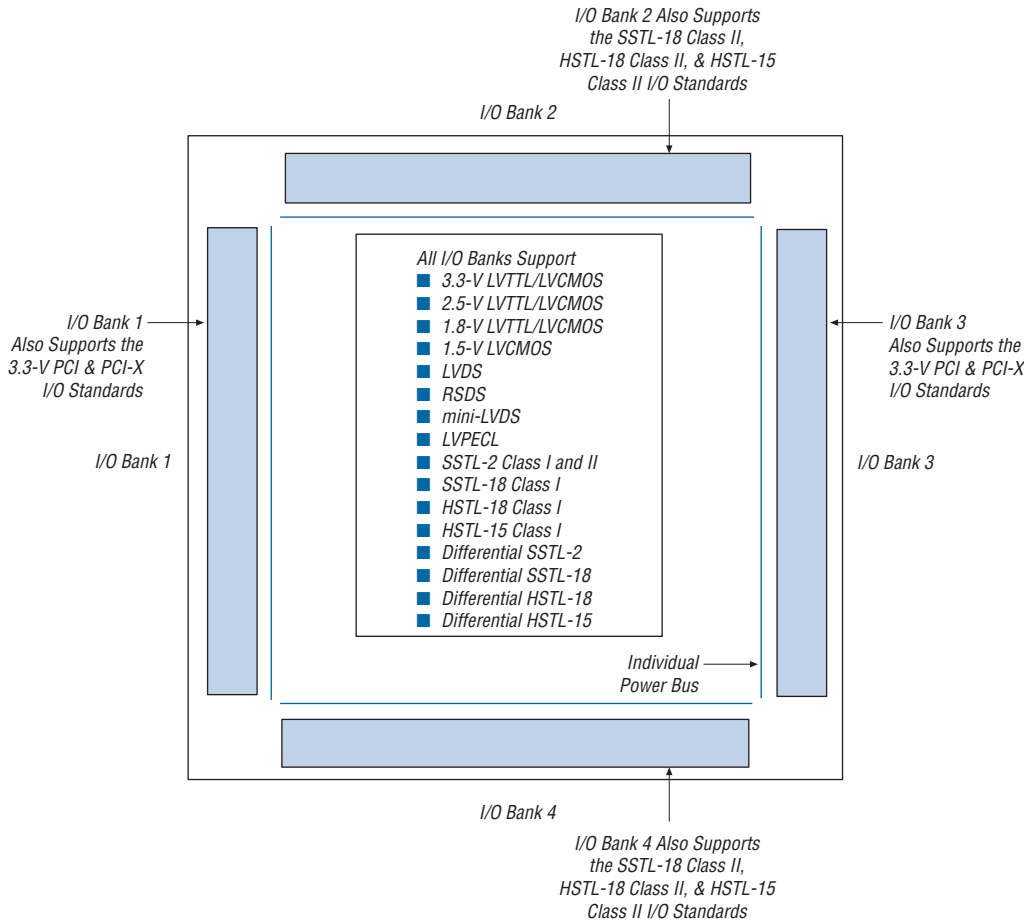
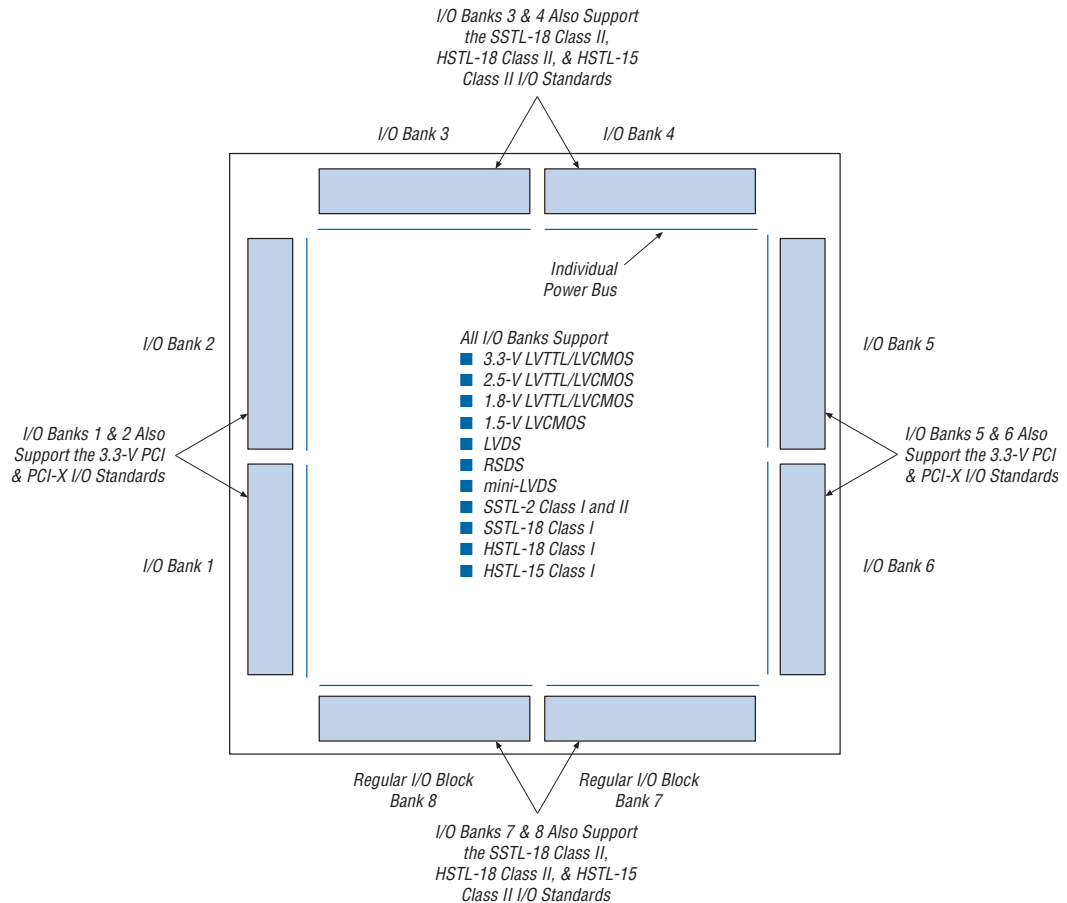

Figure 2–29. EP2C20, EP2C35, EP2C50 & EP2C70 I/O Banks Notes (1), (2)

Notes to Figure 2–28 & 2–29:

- (1) This is a top view of the silicon die.
- (2) This is a graphic representation only. Refer to the pin list and the Quartus II software for exact pin locations.

Each I/O bank has its own VCCIO pins. A single device can support 1.5-V, 1.8-V, 2.5-V, and 3.3-V interfaces; each individual bank can support a different standard with different I/O voltages. Each bank also has dual-purpose VREF pins to support any one of the voltage-referenced standards (e.g., SSTL-2) independently. If an I/O bank does not use voltage-referenced standards, the VREF pins are available as user I/O pins.

Each I/O bank can support multiple standards with the same V_{CCIO} for input and output pins. For example, when V_{CCIO} is 3.3-V, a bank can support LVTTTL, LVCMOS, and 3.3-V PCI for inputs and outputs. Voltage-referenced standards can be supported in an I/O bank using any number of single-ended or differential standards as long as they use the same V_{REF} and a compatible V_{CCIO} value.

MultiVolt I/O Interface

The Cyclone II architecture supports the MultiVolt I/O interface feature, which allows Cyclone II devices in all packages to interface with systems of different supply voltages. Cyclone II devices have one set of V_{CC} pins (V_{CCINT}) that power the internal device logic array and input buffers that use the LVPECL, LVDS, HSTL, or SSTL I/O standards. Cyclone II devices also have four or eight sets of V_{CC} pins (V_{CCIO}) that power the I/O output drivers and input buffers that use the LVTTTL, LVCMOS, or PCI I/O standards.

The Cyclone II V_{CCINT} pins must always be connected to a 1.2-V power supply. If the V_{CCINT} level is 1.2 V, then input pins are 1.5-V, 1.8-V, 2.5-V, and 3.3-V tolerant. The V_{CCIO} pins can be connected to either a 1.5-V, 1.8-V, 2.5-V, or 3.3-V power supply, depending on the output requirements. The output levels are compatible with systems of the same voltage as the power supply (i.e., when V_{CCIO} pins are connected to a 1.5-V power supply, the output levels are compatible with 1.5-V systems). When V_{CCIO} pins are connected to a 3.3-V power supply, the output high is 3.3-V and is compatible with 3.3-V systems. Table 2–21 summarizes Cyclone II MultiVolt I/O support.

V_{CCIO} (V)	Input Signal				Output Signal			
	1.5 V	1.8 V	2.5 V	3.3 V	1.5 V	1.8 V	2.5 V	3.3 V
1.5	✓	✓	✓ (2)	✓ (2)	✓			
1.8	✓ (4)	✓	✓ (2)	✓ (2)	✓ (3)	✓		
2.5			✓	✓	✓ (5)	✓ (5)	✓	

Table 2–21. Cyclone II MultiVolt I/O Support (Part 2 of 2) *Note (1)*

V _{CCIO} (V)	Input Signal				Output Signal			
	1.5 V	1.8 V	2.5 V	3.3 V	1.5 V	1.8 V	2.5 V	3.3 V
3.3			✓ (4)	✓	✓ (6)	✓ (6)	✓ (6)	✓

Notes to Table 2–21:

- (1) The PCI clamping diode must be disabled to drive an input with voltages higher than V_{CCIO}.
- (2) When V_{CCIO} = 1.5-V or 1.8-V and a 2.5-V or 3.3-V input signal feeds an input pin, higher pin leakage current is expected.
- (3) When V_{CCIO} = 1.8-V, a Cyclone II device can drive a 1.5-V device with 1.8-V tolerant inputs.
- (4) When V_{CCIO} = 3.3-V and a 2.5-V input signal feeds an input pin or when V_{CCIO} = 1.8-V and a 1.5-V input signal feeds an input pin, the V_{CCIO} supply current will be slightly larger than expected. The reason for this increase is that the input signal level does not drive to the V_{CCIO} rail, which causes the input buffer to not completely shut off.
- (5) When V_{CCIO} = 2.5-V, a Cyclone II device can drive a 1.5-V or 1.8-V device with 2.5-V tolerant inputs.
- (6) When V_{CCIO} = 3.3-V, a Cyclone II device can drive a 1.5-V, 1.8-V, or 2.5-V device with 3.3-V tolerant inputs.

IEEE Std. 1149.1 (JTAG) Boundary Scan Support

All Cyclone™ II devices provide JTAG BST circuitry that complies with the IEEE Std. 1149.1. JTAG boundary-scan testing can be performed either before or after, but not during configuration. Cyclone II devices can also use the JTAG port for configuration with the Quartus® II software or hardware using either Jam Files (.jam) or Jam Byte-Code Files (.jbc).

Cyclone II devices support IOE I/O standard reconfiguration through the JTAG BST chain. The JTAG chain can update the I/O standard for all input and output pins any time before or during user mode through the CONFIG_IO instruction. Designers can use this capability for JTAG testing before configuration when some of the Cyclone II pins drive or receive from other devices on the board using voltage-referenced standards. Since the Cyclone II device might not be configured before JTAG testing, the I/O pins may not be configured for appropriate electrical standards for chip-to-chip communication. Programming the I/O standards via JTAG allows designers to fully test I/O connections to other devices.



For information on I/O reconfiguration, see *MorphIO: An I/O Reconfiguration Solution for Altera Devices White Paper*.

A device operating in JTAG mode uses four required pins: TDI, TDO, TMS, and TCK. The TCK pin has an internal weak pull-down resistor, while the TDI and TMS pins have weak internal pull-up resistors. The TDO output pin and all JTAG input pin voltage is determined by the V_{CCIO} of the bank where it resides. The bank V_{CCIO} selects whether the JTAG inputs are 1.5-, 1.8-, 2.5-, or 3.3-V compatible.

Cyclone II devices also use the JTAG port to monitor the logic operation of the device with the SignalTap® II embedded logic analyzer. Cyclone II devices support the JTAG instructions shown in [Table 3-1](#).

JTAG Instruction	Instruction Code	Description
SAMPLE/PRELOAD	00 0000 0101	Allows a snapshot of signals at the device pins to be captured and examined during normal device operation, and permits an initial data pattern to be output at the device pins. Also used by the SignalTap II embedded logic analyzer.
EXTEST (1)	00 0000 1111	Allows the external circuitry and board-level interconnects to be tested by forcing a test pattern at the output pins and capturing test results at the input pins.
BYPASS	11 1111 1111	Places the 1-bit bypass register between the TDI and TDO pins, which allows the BST data to pass synchronously through selected devices to adjacent devices during normal device operation.
USERCODE	00 0000 0111	Selects the 32-bit USERCODE register and places it between the TDI and TDO pins, allowing the USERCODE to be serially shifted out of TDO.
IDCODE	00 0000 0110	Selects the IDCODE register and places it between TDI and TDO, allowing the IDCODE to be serially shifted out of TDO.
HIGHZ (1)	00 0000 1011	Places the 1-bit bypass register between the TDI and TDO pins, which allows the BST data to pass synchronously through selected devices to adjacent devices during normal device operation, while tri-stating all of the I/O pins.
CLAMP (1)	00 0000 1010	Places the 1-bit bypass register between the TDI and TDO pins, which allows the BST data to pass synchronously through selected devices to adjacent devices during normal device operation while holding I/O pins to a state defined by the data in the boundary-scan register.
ICR instructions		Used when configuring a Cyclone II device via the JTAG port with a USB Blaster™, ByteBlaster™ II, MasterBlaster™ or ByteBlasterMV™ download cable, or when using a Jam File or JBC File via an embedded processor.
PULSE_NCONFIG	00 0000 0001	Emulates pulsing the nCONFIG pin low to trigger reconfiguration even though the physical pin is unaffected.

Table 3–1. Cyclone II JTAG Instructions (Part 2 of 2)

JTAG Instruction	Instruction Code	Description
CONFIG_IO	00 0000 1101	Allows configuration of I/O standards through the JTAG chain for JTAG testing. Can be executed before, after, or during configuration. Stops configuration if executed during configuration. Once issued, the CONFIG_IO instruction will hold nSTATUS low to reset the configuration device. nSTATUS is held low until the device is reconfigured.
SignalTap II instructions		Monitors internal device operation with the SignalTap II embedded logic analyzer.

Note to Table 3–1:

- (1) Bus hold and weak pull-up resistor features override the high-impedance state of HIGHZ, CLAMP, and EXTEST.

The Cyclone II device instruction register length is 10 bits and the USERCODE register length is 32 bits. Tables 3–2 and 3–3 show the boundary-scan register length and device IDCODE information for Cyclone II devices.

Table 3–2. Cyclone II Boundary-Scan Register Length

Device	Boundary-Scan Register Length
EP2C5	450
EP2C8	597
EP2C20	969
EP2C35	1,449
EP2C50	1,374
EP2C70	1,890

Table 3–3. 32-Bit Cyclone II Device IDCODE (Part 1 of 2)

Device	IDCODE (32 Bits) (1)			
	Version (4 Bits)	Part Number (16 Bits)	Manufacturer Identity (11 Bits)	LSB (1 Bit) (2)
EP2C5	0000	0010 0000 1011 0001	000 0110 1110	1
EP2C8	0000	0010 0000 1011 0010	000 0110 1110	1
EP2C20	0000	0010 0000 1011 0011	000 0110 1110	1
EP2C35	0000	0010 0000 1011 0100	000 0110 1110	1

Table 3–3. 32-Bit Cyclone II Device IDCODE (Part 2 of 2)

Device	IDCODE (32 Bits) (1)			
	Version (4 Bits)	Part Number (16 Bits)	Manufacturer Identity (11 Bits)	LSB (1 Bit) (2)
EP2C50	0000	0010 0000 1011 0101	000 0110 1110	1
EP2C70	0000	0010 0000 1011 0110	000 0110 1110	1

Notes to Table 3–3:

- (1) The most significant bit (MSB) is on the left.
- (2) The IDCODE's least significant bit (LSB) is always 1.

Figure 3–1 shows the timing requirements for the JTAG signals.

Figure 3–1. Cyclone II JTAG Waveform

Table 3–4 shows the JTAG timing parameters and values for Cyclone II devices.

Symbol	Parameter	Min	Max	Unit
t_{JCP}	TCK clock period	40		ns
t_{JCH}	TCK clock high time	20		ns
t_{JCL}	TCK clock low time	20		ns
t_{JPSU}	JTAG port setup time (2)	5		ns
t_{JPH}	JTAG port hold time	10		ns
t_{JPCO}	JTAG port clock to output (2)		13	ns
t_{JPZX}	JTAG port high impedance to valid output (2)		13	ns
t_{JPXZ}	JTAG port valid output to high impedance (2)		13	ns
t_{JSSU}	Capture register setup time (2)	5		ns
t_{JSH}	Capture register hold time	10		ns
t_{JSCO}	Update register clock to output		25	ns
t_{JSZX}	Update register high impedance to valid output		25	ns
t_{JSXZ}	Update register valid output to high impedance		25	ns

Notes to Table 3–4:

- (1) This information is preliminary.
- (2) This specification is shown for 3.3-V LVTTTL/LVCMOS and 2.5-V LVTTTL/LVCMOS operation of the JTAG pins. For 1.8-V LVTTTL/LVCMOS and 1.5-V LVCMOS, the JTAG port and capture register clock setup time is 3 ns and port clock to output time is 15 ns.

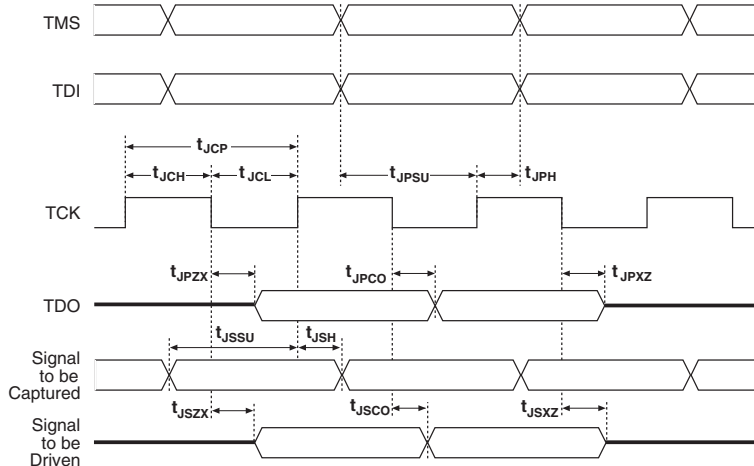

For more information on JTAG, see the *IEEE 1149.1 (JTAG) Boundary-Scan Testing for Cyclone II Devices* chapter in the *Cyclone II Handbook* and *Jam Programming & Test Language Specification*.

SignalTap II Embedded Logic Analyzer

Cyclone II devices support the SignalTap II embedded logic analyzer, which monitors design operation over a period of time through the IEEE Std. 1149.1 (JTAG) circuitry. A designer can analyze internal logic at speed without bringing internal signals to the I/O pins. This feature is particularly important for advanced packages, such as FineLine BGA® packages, because it can be difficult to add a connection to a pin during the debugging process after a board is designed and manufactured.



For more information on the SignalTap II, see the *Signal Tap* chapter of the *Quartus II Handbook, Volume 3*.

Configuration

The logic, circuitry, and interconnects in the Cyclone II architecture are configured with CMOS SRAM elements. Cyclone II devices are reconfigurable and are 100% tested prior to shipment. As a result, the designer does not have to generate test vectors for fault coverage purposes, and can instead focus on simulation and design verification. In addition, the designer does not need to manage inventories of different ASIC designs. Cyclone II devices can be configured on the board for the specific functionality required.

Cyclone II devices are configured at system power-up with data stored in an Altera configuration device or provided by a system controller. The Cyclone II device's optimized interface allows the device to act as controller in an active serial configuration scheme with EPCS serial configuration devices. The serial configuration device can be programmed via SRunner, the ByteBlaster II or USB Blaster download cable, the Altera Programming Unit (APU), or third-party programmers.

In addition to EPCS serial configuration devices, Altera offers in-system programmability (ISP)-capable configuration devices that can configure Cyclone II devices via a serial data stream using the Passive serial (PS) configuration mode. The PS interface also enables microprocessors to treat Cyclone II devices as memory and configure them by writing to a virtual memory location, simplifying reconfiguration. After a Cyclone II device has been configured, it can be reconfigured in-circuit by resetting the device and loading new configuration data. Real-time changes can be made during system operation, enabling innovative reconfigurable applications.

Operating Modes

The Cyclone II architecture uses SRAM configuration elements that require configuration data to be loaded each time the circuit powers up. The process of physically loading the SRAM data into the device is called configuration. During initialization, which occurs immediately after configuration, the device resets registers, enables I/O pins, and begins to operate as a logic device. Together, the configuration and initialization processes are called command mode. Normal device operation is called user mode.

SRAM configuration elements allow Cyclone II devices to be reconfigured in-circuit by loading new configuration data into the device. With real-time reconfiguration, the device is forced into command mode with the `nCONFIG` pin. The configuration process loads different configuration data, reinitializes the device, and resumes user-mode operation. Designers can perform in-field upgrades by distributing new configuration files within the system or remotely.

A built-in weak pull-up resistor pulls all user I/O pins to V_{CCIO} before and during device configuration.

The configuration pins support 1.5-V/1.8-V or 2.5-V/3.3-V I/O standards. The voltage level of the configuration output pins is determined by the V_{CCIO} of the bank where the pins reside. The bank V_{CCIO} selects whether the configuration inputs are 1.5-V, 1.8-V, 2.5-V, or 3.3-V compatible.

Configuration Schemes

Designers can load the configuration data for a Cyclone II device with one of three configuration schemes (see [Table 3–5](#)), chosen on the basis of the target application. Designers can use a configuration device, intelligent controller, or the JTAG port to configure a Cyclone II device. A low-cost configuration device can automatically configure a Cyclone II device at system power-up.

Multiple Cyclone II devices can be configured in any of the three configuration schemes by connecting the configuration enable (nCE) and configuration enable output ($nCEO$) pins on each device.

Table 3–5. Data Sources for Configuration

Configuration Scheme	Data Source
Active serial (AS)	Low-cost serial configuration device
Passive serial (PS)	Enhanced or EPC2 configuration device, MasterBlaster, ByteBlasterMV, ByteBlaster II or USB Blaster download cable, or serial data source
JTAG	MasterBlaster, ByteBlasterMV, ByteBlaster II or USB Blaster download cable or a microprocessor with a Jam or JBC file



For more information on configuration, see the *Configuring Cyclone II Devices* chapter of the *Cyclone II Handbook, Volume 2*.

Cyclone II Automated Single Event Upset Detection

Cyclone II devices offer on-chip circuitry for automated checking of single event upset (SEU) detection. Some applications that require the device to operate error free at high elevations or in close proximity to earth's North or South Pole will require periodic checks to ensure continued data integrity. The error detection cyclic redundancy check (CRC) feature controlled by the **Device & Pin Options** dialog box in the Quartus II software uses a 32-bit CRC circuit to ensure data reliability and is one of the best options for mitigating SEU.

Designers can implement the error detection CRC feature with existing circuitry in Cyclone II devices, eliminating the need for external logic. For Cyclone II devices, the CRC is computed by the device during configuration and checked against an automatically computed CRC during normal operation. The `CRC_ERROR` pin reports a soft error when configuration SRAM data is corrupted, triggering device reconfiguration.

Custom-Built Circuitry

Dedicated circuitry in the Cyclone II devices performs error detection automatically. This error detection circuitry in Cyclone II devices constantly checks for errors in the configuration SRAM cells while the device is in user mode. Designers can monitor one external pin for the error and use it to trigger a re-configuration cycle. The designer can select the desired time between checks by adjusting a built-in clock divider.

Software Interface

In the Quartus II software version 4.1 and later, designers can turn on the automated error detection CRC feature in the Device & Pin Options dialog box. This dialog box allows you to enable the feature and set the internal frequency of the CRC checker between 400 kHz to 100 MHz. This controls the rate that the CRC circuitry verifies the internal configuration SRAM bits in the FPGA device.



For more information on CRC, refer to the *Error Detection Using CRC in Altera FPGAs* Application Note.

Introduction

Cyclone™ II devices offer hot socketing (also known as hot plug-in, hot insertion, or hot swap) and power sequencing support without the use of any external devices. Designers can insert or remove a Cyclone II board in a system during system operation without causing undesirable effects to the board or to the running system bus.

The hot-socketing feature lessens the board design difficulty when using Cyclone II devices on printed circuit boards (PCBs) that also contain a mixture of 3.3-, 2.5-, 1.8-, and 1.5-V devices. With the Cyclone II hot-socketing feature, designers no longer need to ensure a proper power-up sequence for each device on the board.

The Cyclone II hot-socketing feature provides:

- Board or device insertion and removal without external components or board manipulation
- Support for any power-up sequence
- Non-intrusive I/O buffers to system buses during hot insertion

This chapter also discusses the electro-static discharge (ESD) protection and the power-on reset (POR) circuitry in Cyclone II devices. The POR circuitry keeps the devices in the reset state until the V_{CC} is within operating range.

Cyclone II Hot-Socketing Specifications

Cyclone II devices offer hot-socketing capability with all three features listed above without any external components or special design requirements. The hot-socketing feature in Cyclone II devices offers the following:

- Designers can device before power-up without any damage to the device itself.
- I/O pins remain tri-stated during power-up. The device does not drive out before or during power-up, thereby affecting other buses in operation.
- There are no internal current paths from I/O pins to V_{CCIO} or V_{CCINT} power supplies. Signals driven in on I/O pins will not power the V_{CCIO} or V_{CCINT} power buses.

Devices Can Be Driven before Power-Up

You can drive signals into the I/O pins, dedicated input pins, and dedicated clock pins of Cyclone II devices before or during power-up or power-down without damaging the device. Cyclone II devices support any power-up or power-down sequence (V_{CCIO} and V_{CCINT}) to simplify system level design.

I/O Pins Remain Tri-States during Power-Up

A device that does not support hot socketing may interrupt system operation or cause contention by driving out before or during power-up. In a hot-socketing situation, the Cyclone II device's output buffers are turned off during system power-up or power-down. The Cyclone II device also does not drive out until the device is configured and has attained proper operating conditions.

Signal Pins Do Not Have Internal Current Paths to V_{CCIO} or V_{CCINT} Power Supplies

Devices that do not support hot socketing can short power supplies together when powered-up through the device signal pins. This irregular power-up can damage both the driving and driven devices and can disrupt card power-up.

Cyclone II devices do not have a current path from I/O pins, dedicated input pins, or dedicated clock pins to the V_{CCIO} or V_{CCINT} pins before or during power-up. A Cyclone II device may be inserted into (or removed from) a powered-up system board without damaging or interfering with system-board operation. When hot socketing, Cyclone II devices may have a minimal effect on the signal integrity of the backplane.



You can power up or power down the V_{CCIO} and V_{CCINT} pins in any sequence. The power supply ramp rates can range from 100 ns to 100 ms. Both V_{CC} supplies must power down within 100 ms of each other to prevent I/O pins from driving out. During hot socketing, the I/O pin capacitance is less than 15 pF and the clock pin capacitance is less than 20 pF. I/O pins can be driven by active signals with a rise and fall time of 2 to 40 ns. Cyclone II devices meet the following hot-socketing specification.

The hot-socketing DC specification is: $| I_{IOPIN} | < 300 \mu A$

The hot-socketing AC specification is: $| I_{IOPIN} | < 8 \text{ mA}$
or $| I_{IOPIN} | > 8 \text{ mA}$ for 10 ns or less

I_{IOPIN} is the current at any user I/O pin on the device. The AC specification has two requirements. The peak current during power-up or power-down is < 8 mA. The peak current can exceed 8 mA for 10 ns or less.

A possible concern for semiconductor devices in general regarding hot socketing is the potential for latch-up. Latch-up can occur when electrical subsystems are hot socketed into an active system. During hot socketing, the signal pins may be connected and driven by the active system before the power supply can provide current to the device's V_{CC} and ground planes. This condition can lead to latch-up and cause a low-impedance path from V_{CC} to ground within the device. As a result, the device extends a large amount of current, possibly causing electrical damage.

Altera has ensured by design of the I/O buffers and hot-socketing circuitry, that Cyclone II devices are immune to latch-up during hot socketing.

Hot-Socketing Feature Implementation in Cyclone II Devices

The hot-socketing feature turns off the output buffer during power up (either V_{CCINT} or V_{CCIO} supplies) or power down. The hot-socket circuit will generate an internal `HOTSCKT` signal when either V_{CCINT} or V_{CCIO} is below the threshold voltage. Designs cannot use the `HOTSCKT` signal for other purposes. The `HOTSCKT` signal will cut off the output buffer to ensure that no DC current (except for weak pull-up leakage current) leaks through the pin. When V_{CC} ramps up slowly, V_{CC} is still relatively low even after the internal POR signal (not available to the FPGA fabric used by customer designs) is released and the configuration is finished. The `CONF_DONE`, `nCEO`, and `nSTATUS` pins fail to respond, as the output buffer cannot drive out because the hot-socketing circuitry will keep the I/O pins tristated at this low V_{CC} voltage. Therefore, the hot-socketing circuit has been removed on these configuration output or bidirectional pins to ensure that they are able to operate during configuration. These pins are expected to drive out during power-up and power-down sequences.

Each I/O pin has the circuitry shown in [Figure 4-1](#).

Figure 4–1. Hot-Socketing Circuit Block Diagram for Cyclone II Devices

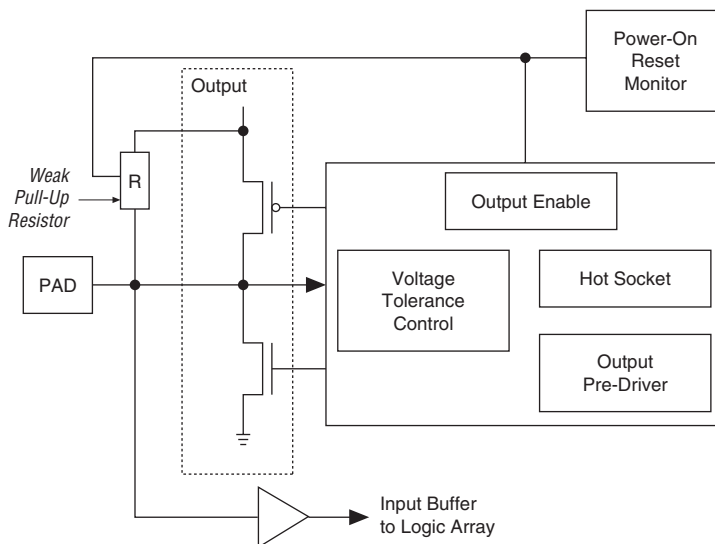

The POR circuit monitors V_{CCINT} voltage level and keeps I/O pins tri-stated until the device is in user mode. The weak pull-up resistor (R) from the I/O pin to V_{CCIO} keeps the I/O pins from floating. The voltage tolerance control circuit permits the I/O pins to be driven by 3.3 V before V_{CCIO} and/or V_{CCINT} are powered, and it prevents the I/O pins from driving out when the device is not in user mode. The hot socket circuit prevents I/O pins from internally powering V_{CCIO} and V_{CCINT} when driven by external signals before the device is powered.



For more information, see the *DC Characteristics & Timing Specifications* chapter in Volume 1 of the *Cyclone II Device Handbook* for the value of the internal weak pull-up resistors.

Figure 4–2 shows a transistor level cross section of the Cyclone II device I/O buffers. This design ensures that the output buffers do not drive when V_{CCIO} is powered before V_{CCINT} or if the I/O pad voltage is higher than V_{CCIO} . This also applies for sudden voltage spikes during hot socketing. There is no current path from signal I/O pins to V_{CCINT} or V_{CCIO} during hot socketing. The V_{PAD} leakage current charges the voltage tolerance control circuit capacitance.

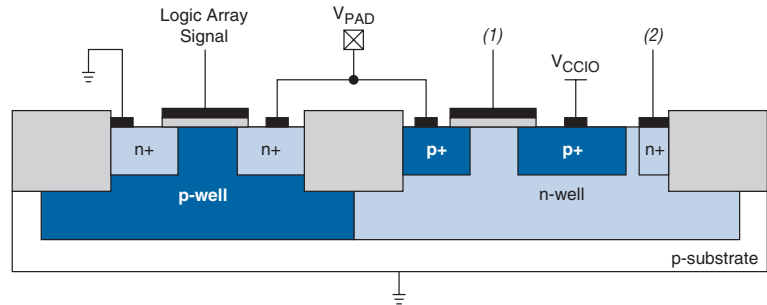
Figure 4–2. Transistor Level Diagram of FPGA Device I/O Buffers

Note to Figure 4–2:

- (1) This is the logic array signal or the larger of either the V_{CCIO} or V_{PAD} signal.
- (2) This is the larger of either the V_{CCIO} or V_{PAD} signal.

ESD Protection

Electro-static discharge (ESD) occurs when a charge moves from one surface to another. ESD is a charge that moves between two surfaces with different potentials. Destructive ESD can occur when the voltage differential between the two surfaces is sufficiently high to break down the dielectric strength of the medium separating the two surfaces. When a static charge moves, it becomes a current that damages or destroys gate oxide, metallization, and junctions.

ESD can occur in one of four ways: a charged body can touch an integrated circuit (IC), a charged IC can touch a grounded surface, a charged machine can touch an IC, or an electrostatic field can induce a voltage across a dielectric sufficient to break it down.

ESD Testing

ESD can cause destructive damage to semiconductor IC devices like FPGAs. The industry has introduced testing standards to minimize the detrimental effects of ESD by ensuring all devices have undergone proper standardized testing for quality and reliability. Three major ESD testing methods exist for defining a passing level. Altera tests to human-body model (HBM) and charged-device model (CDM). Machine model (MM) testing is not typically performed because the results are similar to HBM testing.

Human-Body Model

The HBM simulates the action of a human body discharging accumulated static charge through a device to ground. This model uses a series RC network consisting of a 100-pF capacitor and a 1,500- Ω resistor. Altera production devices meet the HBM ESD specifications of 1,000 V.

Machine Model

The MM simulates a machine discharging accumulated static charge through a device to ground. This model uses a series RC network of a 200-pF capacitor, and nominal series resistance of less than 1 Ω . The output waveform usually is described in terms of peak current and oscillating frequency for a given discharge voltage.

Charged-Device Model

The CDM simulates charging and discharging events that occur during the manufacturing and testing processes. Potential for CDM events occur when there is metal-to-metal contact in manufacturing. One example is a device sliding down a shipping tube and hitting a metal surface. The CDM addresses the possibility that a charge may reside on a lead frame or package (e.g., from shipping) and discharge through a pin that subsequently is grounded, causing damage to sensitive circuitry in the path. The discharge current is limited only by the parasitic impedance and capacitance of the device. CDM testing consists of charging a package to a specified voltage, then discharging this voltage through the relevant package leads. Altera production devices meet the CDM ESD specification of 500 V.

ESD Circuitry

The CMOS output drivers in the I/O pins intrinsically provide ESD protection. ESD voltage strikes can cause a positive voltage zap or a negative voltage zap.

A positive ESD voltage zap occurs when a positive voltage is present on an I/O pin because of an ESD charge event. This can cause the N+ (drain)/P-substrate junction of the N-channel drain to break down and the N+ (drain)/P-substrate/N+ (source) intrinsic bipolar transistor to turn on to discharge ESD current from I/O pin to ground. The arrows in [Figure 4-3](#) show the ESD current discharge path during a positive ESD zap.

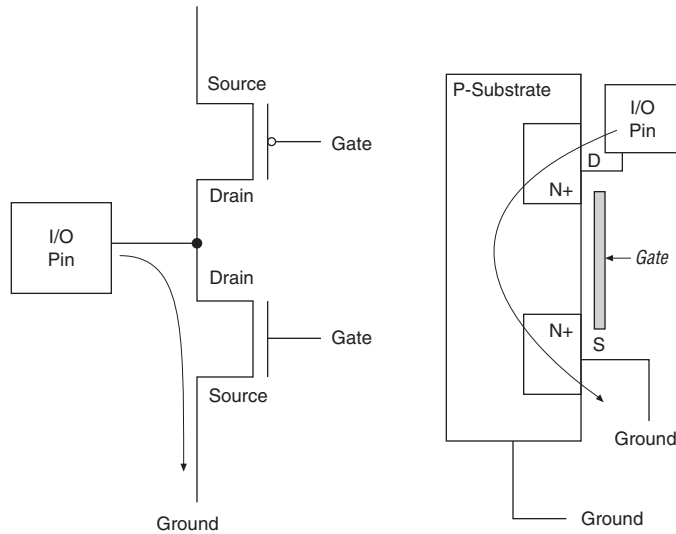
Figure 4–3. ESD Protection During Positive Voltage Zap

When the I/O pin receives a negative ESD zap at the pin that is less than -0.7 V (0.7 V is the voltage drop across a diode), the intrinsic P-substrate/N+ drain diode is forward biased. Hence, the discharge ESD current path is from ground to the I/O pin, as shown in [Figure 4–4](#).

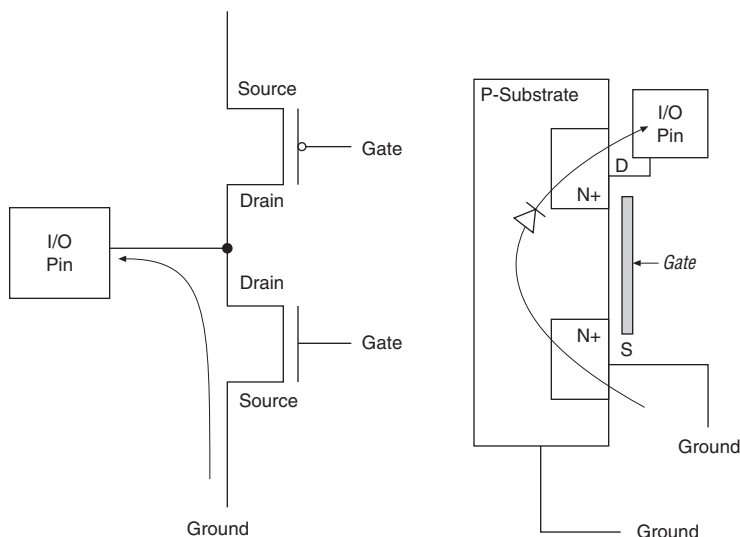
Figure 4–4. ESD Protection During Negative Voltage Zap

For the maximum specification of ESD protection, see the *DC Characteristics & Timing Specifications* chapter in Volume 1 of the *Cyclone II Device Handbook*. For more information on quality and reliability, see the *Reliability Report* for Altera devices.

Power-On Reset Circuitry

Cyclone II devices have a POR circuit to keep the whole device system in reset state until the power supply voltage levels have stabilized during power-up. The POR circuit monitors the V_{CCINT} and V_{CCIO} voltage levels and tri-states all the user I/O pins while V_{CC} is ramping up until normal user levels are reached. The POR circuitry also ensures that the V_{CCIO} level of the two I/O banks that contains configuration pins (I/O banks 1 and 3 for EP2C5 and EP2C8, I/O banks 1 and 6 for EP2C20, EP2C35, EP2C50, and EP2C70) as well as the logic array V_{CCINT} voltage reach an acceptable level before configuration is triggered. After the Cyclone II device enters user mode, the POR circuit continues to monitor the V_{CCINT} voltage level so that a brown-out condition during user mode can be detected. If there is a V_{CCINT} voltage sag below the POR trip point at ~600 to 700 mV during user mode, the POR circuit resets the device. If there is a V_{CCIO} voltage sag during user mode, the POR circuit will not reset the device.

When power is applied to a Cyclone II device, a POR event occurs if V_{CC} reaches the recommended operating range within a certain period of time (specified as a maximum V_{CC} rise time). The maximum V_{CC} rise time for Cyclone II devices is 100 ms. The minimum POR time is 100 ms for Cyclone II devices. However, the designer can extend initialization time by asserting the `nSTATUS` pin using an external component.

Conclusion

Cyclone II devices are hot socketable and support all power-up and power-down sequences with the one requirement that V_{CCIO} and V_{CCINT} be powered up and down within 100 ms of each other to keep the I/O pins from driving out. Cyclone II devices do not require any external devices for hot socketing and power sequencing and have robust ESD protection.

Operating Conditions

Cyclone™ II devices are offered in both commercial and industrial grades. Commercial devices are offered in -6 (fastest), -7, -8 speed grades.

All parameter limits are representative of worst-case supply voltage and junction temperature conditions. Unless otherwise noted, the parameter values in this chapter apply to all Cyclone II devices. AC and DC characteristics are specified using the same numbers for both commercial and industrial grades. All parameters representing voltages are measured with respect to ground.

Tables 5-1 through 5-4 provide information on absolute maximum ratings.

Table 5-1. Cyclone II Device Absolute Maximum Ratings Notes (1), (2)

Symbol	Parameter	Conditions	Minimum	Maximum	Unit
V_{CCINT}	Supply voltage	With respect to ground	-0.5	1.8	V
V_{CCIO}	Output supply voltage		-0.5	4.6	V
V_{IN}	DC input voltage		-0.5	4.6	V
I_{OUT}	DC output current, per pin		-25	40	mA
T_{STG}	Storage temperature	No bias	-65	150	°C
T_J	Junction temperature	BGA packages under bias		125	°C

Notes to Table 5-1:

- Conditions beyond those listed in this table will cause permanent damage to a device. These are stress ratings only. Functional operation at these levels or any other conditions beyond those specified in this chapter is not implied. Additionally, device operation at the absolute maximum ratings for extended periods of time may have adverse effects on the device reliability.
- See the *Operating Requirements for Altera Devices Data Sheet* for more information.

Table 5–2 specifies the recommended operating conditions for Cyclone II devices. It shows the allowed voltage ranges for V_{CCINT} , V_{CCIO} , and the operating junction temperature (T_J). The LVTTTL and LVCMOS inputs are powered by V_{CCIO} only. The LVPECL input buffers on dedicated clock pins are powered by V_{CCINT} . The SSTL, HSTL, LVDS input buffers are powered by both V_{CCINT} and V_{CCIO} .

Symbol	Parameter	Conditions	Minimum	Maximum	Unit
V_{CCINT}	Supply voltage for internal logic and input buffers	(1)	1.15	1.25	V
V_{CCIO} (2)	Supply voltage for output buffers, 3.3-V operation	(1)	3.00 (3)	3.60 (3)	V
	Supply voltage for output buffers, 2.5-V operation	(1)	2.375	2.625	V
	Supply voltage for output buffers, 1.8-V operation	(1)	1.71 (2)	1.89	V
	Supply voltage for output buffers, 1.5-V operation	(1)	1.4	1.6	V
T_J (4)	Operating junction temperature	For commercial use	0	85	°C
		For industrial use	–40	100	°C

Notes to Table 5–2:

- (1) The maximum V_{CC} (both V_{CCIO} and V_{CCINT}) rise time is 100 ms, and V_{CC} must rise monotonically.
- (2) The V_{CCIO} range given here spans the lowest and highest operating voltages of all supported I/O standards. The recommended V_{CCIO} range specific to each of the single-ended I/O standards is given in Table 5–6, and those specific to the differential standards is given in Table 5–8.
- (3) The minimum and maximum values of 3.0 V and 3.6 V, respectively, for V_{CCIO} only applies to the PCI and PCI-X I/O standards. See Table 5–6 for the voltage range of other I/O standards.
- (4) Contact Altera Applications for θ_{JA} and θ_{JC} values.

Symbol	Parameter	Conditions	Minimum	Typical	Maximum	Unit
V_{IN}	Input voltage	(1), (2)	–0.5		4.0	V
I_I	Input pin leakage current	$V_I = V_{CCIOmax}$ to 0 V (3)	–10		10	μA
V_{OUT}	Output voltage		0		V_{CCIO}	V
I_{OZ}	Tri-stated I/O pin leakage current	$V_O = V_{CCIOmax}$ to 0 V (3)	–10		10	μA

Table 5–3. DC Characteristics for User I/O, Dual-Purpose & Dedicated Pins (Part 2 of 2)

Symbol	Parameter	Conditions	Minimum	Typical	Maximum	Unit
I_{CC0}	V_{CC} supply current (standby) (all memory blocks in power-down mode)	$V_I =$ ground, no load, no toggling inputs				mA
R_{CONF}	Value of I/O pin pull-up resistor before and during configuration	$V_{CCIO} = 3.0$ V (4)	20		50	k Ω
		$V_{CCIO} = 2.375$ V (4)	30		80	k Ω
		$V_{CCIO} = 1.71$ V (4)	60		150	k Ω

Notes to Table 5–3:

- (1) All pins, including dedicated inputs, clock, I/O, and JTAG pins, may be driven before V_{CCINT} and V_{CCIO} are powered.
- (2) The minimum DC input is -0.5 V. During transitions, the inputs may undershoot to -2.0 V or overshoot to the voltages shown in Table 5–4, based on input duty cycle for input currents less than 100 mA. The overshoot is dependent upon duty cycle of the signal. The DC case is equivalent to 100% duty cycle.
- (3) This value is specified for normal device operation. The value may vary during power-up. This applies for all V_{CCIO} settings (3.3, 2.5, 1.8, and 1.5 V).
- (4) Pin pull-up resistance values will lower if an external source drives the pin higher than V_{CCIO} .

Table 5–4 shows the maximum V_{IN} overshoot voltage and the dependency on the duty cycle of the input signal. See Table 5–3 for more information.

Table 5–4. V_{IN} Overshoot Voltage for All Input Buffers

Maximum V_{IN} (V)	Input Signal Duty Cycle
4.0	100% (DC)
4.1	90%
4.2	50%
4.3	30%
4.4	17%
4.5	10%

Single-Ended I/O Standards

Tables 5–6 and 5–7 provide operating condition information when using single-ended I/O standards with Cyclone II devices. Table 5–5 provides descriptions for the voltage and current symbols used in Tables 5–6 and 5–7.

Table 5–5. Voltage & Current Symbol Definitions

Symbol	Definition
V_{CCIO}	Supply voltage for single-ended inputs and for output drivers
V_{REF}	Reference voltage for setting the input switching threshold
V_{IL}	Input voltage that indicates a low logic level
V_{IH}	input voltage that indicates a high logic level
V_{OL}	Output voltage that indicates a low logic level
V_{OH}	Output voltage that indicates a high logic level
I_{OL}	Output current condition under which V_{OL} is tested
I_{OH}	Output current condition under which V_{OH} is tested
V_{TT}	Voltage applied to a resistor termination as specified by HSTL and SSTL standards

Table 5–6. Recommended Operating Conditions for User I/O Pins Using Single-Ended I/O Standards (Part 1 of 2) *Note (1)*

I/O Standard	V_{CCIO} (V)			V_{REF} (V)			V_{IL} (V)	V_{IH} (V)
	Min	Nom	Max	Min	Nom	Max	Max	Min
3.3-V LVTTTL and LVCMOS	3.135	3.3	3.465				0.8	1.7
2.5-V LVTTTL and LVCMOS	2.375	2.5	2.625				0.7	1.7
1.8-V LVTTTL and LVCMOS	1.710	1.8	1.890				$0.35 \times V_{CCIO}$	$0.65 \times V_{CCIO}$
1.5-V LVCMOS	1.425	1.5	1.575				$0.35 \times V_{CCIO}$	$0.65 \times V_{CCIO}$
PCI and PCI-X	3.000	3.3	3.600				$0.3 \times V_{CCIO}$	$0.5 \times V_{CCIO}$
SSTL-2 class I	2.375	2.5	2.625	1.19	1.25	1.31	$V_{REF} - 0.18$	$V_{REF} + 0.18$
SSTL-2 class II	2.375	2.5	2.625	1.19	1.25	1.31	$V_{REF} - 0.18$	$V_{REF} + 0.18$
SSTL-18 class I	1.7	1.8	1.9	0.833	0.9	0.969	$V_{REF} - 0.125$	$V_{REF} + 0.125$
SSTL-18 class II	1.7	1.8	1.9	0.833	0.9	0.969	$V_{REF} - 0.125$	$V_{REF} + 0.125$
1.8-V HSTL class I	1.71	1.8	1.89	0.85	0.9	0.95	$V_{REF} - 0.1$	$V_{REF} + 0.1$

Table 5–6. Recommended Operating Conditions for User I/O Pins Using Single-Ended I/O Standards (Part 2 of 2) *Note (1)*

I/O Standard	V_{CCIO} (V)			V_{REF} (V)			V_{IL} (V)	V_{IH} (V)
	Min	Nom	Max	Min	Nom	Max	Max	Min
1.8-V HSTL class II	1.71	1.8	1.89	0.85	0.9	0.95	$V_{REF} - 0.1$	$V_{REF} + 0.1$
1.5-V HSTL class I	1.425	1.5	1.575	0.71	0.75	0.79	$V_{REF} - 0.1$	$V_{REF} + 0.1$
1.5-V HSTL class II	1.425	1.5	1.575	0.71	0.75	0.79	$V_{REF} - 0.1$	$V_{REF} + 0.1$

Note to Table 5–6:

(1) Nominal values (Nom) are for $T_A = 25^\circ\text{C}$, $V_{CCINT} = 1.2\text{ V}$, and $V_{CCIO} = 1.5, 1.8, 2.5,$ and 3.3 V .

Table 5–7. DC Characteristics of User I/O Pins Using Single-Ended Standards (Part 1 of 2) *Note (1)*

I/O Standard	Current Drive Strength Setting (mA)	Test Conditions		Voltage Thresholds	
		I_{OL} (mA)	I_{OH} (mA)	Maximum V_{OL} (V)	Minimum V_{OH} (V)
3.3-V LVTTTL and LVCMOS	4	4	–4	0.4	2.4
	8	8	–8		
	12	12	–12		
	16	16	–16		
	20	20	–20		
	24	24	–24		
2.5-V LVTTTL and LVCMOS	4	4	–4	0.4	$V_{CCIO} - 0.4$
	8	8	–8		
	12	12	–12		
	16	16	–16		
1.8-V LVTTTL and LVCMOS	2	2	–2	0.4	$V_{CCIO} - 0.4$
	4	4	–4		
	6	6	–6		
	8	8	–8		
	10	10	–10		
	12	12	–12		
1.5-V LVCMOS	2	2	–2	$0.25 \times V_{CCIO}$	$0.75 \times V_{CCIO}$
	4	4	–4		
	6	6	–6		
	8	8	–8		
PCI and PCI-X		1.5	–0.5	$0.1 \times V_{CCIO}$	$0.9 \times V_{CCIO}$

Table 5–7. DC Characteristics of User I/O Pins Using Single-Ended Standards (Part 2 of 2) *Note (1)*

I/O Standard	Current Drive Strength Setting (mA)	Test Conditions		Voltage Thresholds	
		I _{OL} (mA)	I _{OH} (mA)	Maximum V _{OL} (V)	Minimum V _{OH} (V)
SSTL-2 class I	8	8	–8	V _{TT} – 0.57	V _{TT} + 0.57
	12	12	–12		
SSTL-2 class II	16	16	–16	V _{TT} – 0.76	V _{TT} + 0.76
	20	20	–20		
	24	24	–24		
SSTL-18 class I	4	4	–4	V _{TT} – 0.475	V _{TT} + 0.475
	6	6	–6		
	8	8	–8		
	10	10	–10		
	12	12	–12		
SSTL-18 class II	8	8	–8	0.28	V _{CCIO} – 0.28
	16	16	–16		
	18	18	–18		
1.8-V HSTL class I	4	4	–4	0.4	V _{CCIO} – 0.4
	6	6	–6		
	8	8	–8		
	10	10	–10		
	12	12	–12		
1.8-V HSTL class II	16	16	–16	0.4	V _{CCIO} – 0.4
	18	18	–18		
	20	20	–20		
1.5-V HSTL class I	4	4	–4	0.4	V _{CCIO} – 0.4
	6	6	–6		
	8	8	–8		
	10	10	–10		
	12	12	–12		
1.5V HSTL class II	16	16	–16	0.4	V _{CCIO} – 0.4

Note to Table 5–7:

(1) The values in this table are based on the conditions listed in Tables 5–2 and 5–6.

Differential I/O Standards

The RSDS and mini-LVDS I/O standards are only supported on output pins. The LVDS I/O standard is supported on both receiver input pins and transmitter output pins.



For more information on how these differential I/O standards are implemented, see the *High-Speed Differential Interfaces in Cyclone II Devices* chapter in Volume 1 of the *Cyclone II Device Handbook*.

Figure 5–1 shows the receiver input waveforms for all differential I/O standards (LVDS, LVPECL, differential 1.5-V HSTL class I and II, differential 1.8-V HSTL class I and II, differential SSTL-2 class I and II, and differential SSTL-18 class I and II).

Figure 5–1. Receiver Input Waveforms for Differential I/O Standards

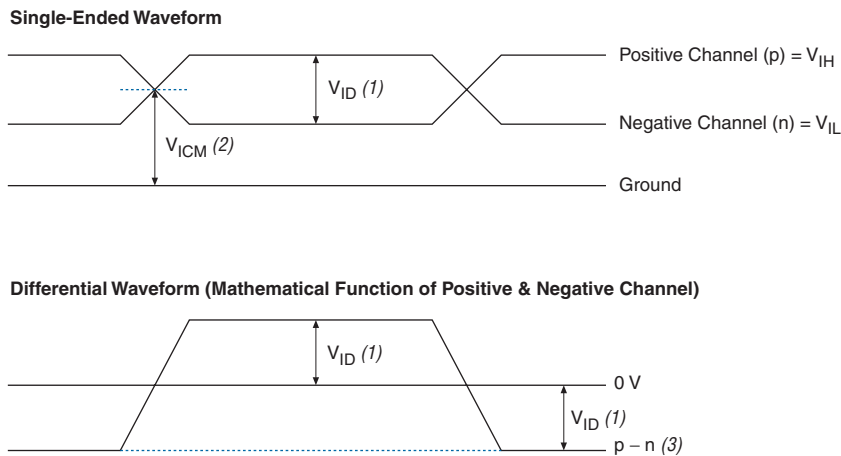

Notes to Figure 5–1:

- (1) V_{ID} is the differential input voltage. $V_{ID} = |p - n|$.
- (2) V_{ICM} is the input common mode voltage. $V_{ICM} = (p - n)/2$.
- (3) The $p - n$ waveform is a function of the positive channel (p) and the negative channel (n).

Table 5–8 shows the recommended operating conditions for user I/O pins with differential I/O standards.

Table 5–8. Recommended Operating Conditions for User I/O Pins Using Differential Signal I/O Standards

I/O Standard	V _{CCIO} (V)			V _{ID} (V) (1)			V _{ICM} (V)			V _{IL} (V)		V _{IH} (V)	
	Min	Nom	Max	Min	Nom	Max	Min	Nom	Max	Min	Max	Min	Max
LVDS	2.375	2.5	2.625	0.1			0.1	1.25	1.8				
mini-LVDS (2)	2.375	2.5	2.625										
RSDS (2)	2.375	2.5	2.625										
LVPECL (3)	3.135	3.3	3.465	0.1	0.6	0.95				0	2.2	2.1	2.88
Differential 1.5-V HSTL class I and II (4)	1.425	1.5	1.575	0.2		V _{CCIO} + 0.6	0.68		0.9		V _{REF} - 0.1	V _{REF} + 0.1	
Differential 1.8-V HSTL class I and II (4)	1.71	1.8	1.89								V _{REF} - 0.1	V _{REF} + 0.1	
Differential SSTL-2 class I and II (5)	2.375	2.5	2.625	0.36		V _{CCIO} + 0.6	0.5 × V _{CCIO} - 0.2	0.5 × V _{CCIO}	0.5 × V _{CCIO} + 0.2		V _{REF} - 0.1	V _{REF} + 0.1	
Differential SSTL-18 class I and II (5)	1.7	1.8	1.9	0.25		V _{CCIO} + 0.6	0.5 × V _{CCIO} - 0.2	0.5 × V _{CCIO}	0.5 × V _{CCIO} + 0.2		V _{REF} - 0.1	V _{REF} + 0.1	

Notes to Table 5–8:

- Refer to the *High-Speed Differential Interfaces in Cyclone II Devices* chapter in Volume 1 of the *Cyclone II Device Handbook* for measurement conditions on V_{ID}.
- The RSDS and mini-LVDS I/O standards are only supported on output pins.
- The LVPECL I/O standard is only supported on clock input pins. This I/O standard is not supported on output pins.
- The differential 1.8-V and 1.5-V HSTL I/O standards are only supported on clock input pins and PLL output clock pins.
- The differential SSTL-18 and SSTL-2 I/O standards are only supported on clock input pins and PLL output clock pins.

Figure 5–2 shows the transmitter output waveforms for all supported differential output standards (LVDS, mini-LVDS, RSDS, differential 1.5-V HSTL class I and II, differential 1.8-V HSTL class I and II, differential SSTL-2 class I and II, and differential SSTL-18 class I and II).

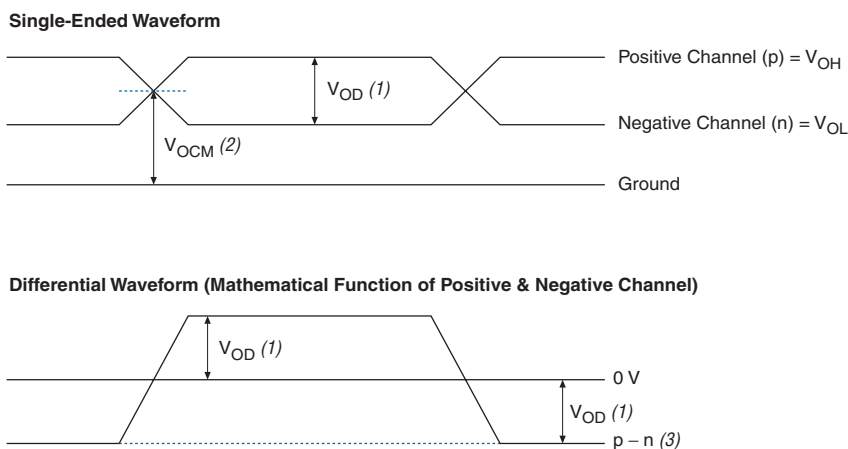
Figure 5–2. Transmitter Output Waveforms for Differential I/O Standards

Notes to **Figures 5–1 & 5–2:**

- (1) V_{OD} is the output differential voltage. $V_{OD} = |p - n|$.
- (2) V_{OCM} is the output common mode voltage. $V_{OCM} = (p + n)/2$.
- (3) The $p - n$ waveform is a function of the positive channel (p) and the negative channel (n).

Table 5–9 shows the DC characteristics for user I/O pins with differential I/O standards.

I/O Standard	V_{OD} (mV)			ΔV_{OD} (mV)		V_{OCM} (V)			V_{OH} (V)		V_{OL} (V)	
	Min	Typ	Max	Min	Max	Min	Typ	Max	Min	Max	Min	Max
LVDS	247		600		50	1.125	1.25	1.375				
mini-LVDS (2)	300		600		50	1	1.2	1.4				
RSDS (2)	100	200	600			0.5	1.2	1.5				
Differential 1.5-V HSTL class I and II (3)									$V_{CCIO} - 0.4$			0.4
Differential 1.8-V HSTL class I and II (3)									$V_{CCIO} - 0.4$			0.4
Differential SSTL-2 class I (4)									$V_{TT} + 0.57$			$V_{TT} - 0.57$

Table 5–9. DC Characteristics for User I/O Pins Using Differential I/O Standards (Part 2 of 2) *Note (1)*

I/O Standard	V _{OD} (mV)			ΔV _{OD} (mV)		V _{OCM} (V)			V _{OH} (V)		V _{OL} (V)	
	Min	Typ	Max	Min	Max	Min	Typ	Max	Min	Max	Min	Max
Differential SSTL-2 class II (4)									V _{TT} + 0.76			V _{TT} – 0.76
Differential SSTL-18 class I (4)						0.5 × V _{CCIO} – 0.125	0.5 × V _{CCIO}	0.5 × V _{CCIO} + 0.125	V _{TT} + 0.475			V _{TT} – 0.475
Differential SSTL-18 class II (4)						0.5 × V _{CCIO} – 0.125	0.5 × V _{CCIO}	0.5 × V _{CCIO} + 0.125	V _{CCIO} – 0.28			0.28

Notes to Table 5–9:

- (1) The LVPECL I/O standard is only supported on clock input pins. This I/O standard is not supported on output pins.
- (2) The RSDS and mini-LVDS I/O standards are only supported on output pins.
- (3) The differential 1.8-V HSTL and differential 1.5-V HSTL I/O standards are only supported on clock input pins and PLL output clock pins.
- (4) The differential SSTL-18 and SSTL-2 I/O standards are only supported on clock input pins and PLL output clock pins.

DC Characteristics for Different Pin Types

Table 5–10 shows which types of pins that support bus hold circuitry.

Table 5–10. Bus Hold Support

Pin Type	Bus Hold
I/O pins using single-ended I/O standards	Yes
I/O pins using differential I/O standards	No
Dedicated clock pins	No
JTAG	No
Configuration pins	No

Table 5–11 specifies the bus hold parameters for general I/O pins.

Parameter	Conditions	V_{CCIO} Level						Unit
		1.8 V		2.5 V		3.3 V		
		Min	Max	Min	Max	Min	Max	
Bus-hold low, sustaining current	$V_{IN} > V_{IL}(\text{maximum})$	30		50		70		μA
Bus-hold high, sustaining current	$V_{IN} < V_{IL}(\text{minimum})$	–30		–50		–70		μA
Bus-hold low, overdrive current	$0\text{ V} < V_{IN} < V_{CCIO}$		200		300		500	μA
Bus-hold high, overdrive current	$0\text{ V} < V_{IN} < V_{CCIO}$		–200		–300		–500	μA
Bus-hold trip point (2)		0.68	1.07	0.7	1.7	0.8	2.0	V

Notes to Table 5–11:

- (1) There is no specification for bus-hold at $V_{CCIO} = 1.5\text{ V}$ for the HSTL I/O standard.
- (2) The bus-hold trip points are based on calculated input voltages from the JEDEC standard.

Table 5–12 shows the Cyclone II device pin capacitance for different I/O pin types.

Symbol	Parameter	Typical	Unit
C_{IO}	Input capacitance for user I/O pin	(2)	pF
C_{LVDS}	Input capacitance for dual-purpose LVDS/user I/O pin	(2)	pF
C_{VREF}	Input capacitance for dual-purpose VREF and user I/O pin.	(2)	pF
C_{DPCLK}	Input capacitance for dual-purpose DPCLK and user I/O pin.	(2)	pF
C_{CLK}	Input capacitance for clock pin.	(2)	pF

Notes to Table 5–12:

- (1) Capacitance is sample-tested only. Capacitance is measured using time-domain reflectometry (TDR). Measurement accuracy is within $\pm 0.5\text{ pF}$.
- (2) This specification will be available in a future version of the data sheet.

Table 5–13 shows the specification for ESD for all Cyclone II device pins.

Symbol	Parameter	Maximum	Unit
ESD _{HBM}	Human body model	1,000	V
ESD _{CDM}	Charged device model	500	V
	Charged device model for PLL power pins and dedicated clocks 1, 3, 9, and 11	300	V

Power Consumption

Designers can calculate the power usage for their design using the Altera power calculator and the simulation-based power estimation feature in the Quartus® II software.

The interactive power calculator is typically used prior to designing the FPGA in order to get a magnitude estimate of the device power. The Quartus II software simulation-based power estimation feature allows designers to apply test vectors against their design for more accurate power consumption modeling.

In both cases, these calculations should only be used as an estimation of power, not as a specification.



Contact Altera Applications for information on the Cyclone II power calculator.

Cyclone II devices require a certain amount of power-up current to successfully power up because of the nature of the leading-edge process on which they are fabricated. Table 5–14 will show the maximum power-up current required to power up a Cyclone II device after device characterization has been performed.

Device	Maximum Power-Up Current Requirement	Unit
EP2C5	(1)	mA
EP2C8	(1)	mA
EP2C20	(1)	mA
EP2C35	(1)	mA
EP2C50	(1)	mA
EP2C70	(1)	mA

Note to Table 5–14:

(1) This specification will be available in a future version of the data sheet.

Designers should select power supplies and regulators that can supply this amount of current when designing with Cyclone II devices. This specification is for commercial operating conditions. Measurements were performed with an isolated Cyclone II device on the board. Decoupling capacitors were not used in this measurement. To factor in the current for decoupling capacitors, sum up the current for each capacitor using the following equation:

$$I = C (dV/dt)$$

The exact amount of current that will be consumed varies according to the process, temperature, and power ramp rate. The duration of the I_{CCINT} power-up requirement depends on the V_{CCINT} voltage supply rise time.

Altera recommends using the Cyclone II Power Calculator to estimate the user-mode I_{CCINT} consumption and then select power supplies or regulators based on the higher value.

Timing Specifications

The DirectDrive™ technology and MultiTrack™ interconnect ensure predictable performance, accurate simulation, and accurate timing analysis across all Cyclone II device densities and speed grades. This section describes and specifies the performance, internal, external, and PLL timing specifications.

This section shows the timing models for Cyclone II devices. Commercial devices will meet this timing over the commercial temperature range. Industrial devices will meet this timing over the industrial temperature range. All specifications are representative of worst-case supply voltage and junction temperature conditions.

The preliminary timing model will be added into a future revision of this Data Sheet.

Preliminary & Final Timing Specifications

Timing models can have either preliminary or final status. The Quartus II software issues an informational message during the design compilation if the timing models are preliminary. [Table 5-15](#) shows the status of the Cyclone II device timing models.

Preliminary status means the timing model is subject to change. Initially, timing numbers are created using simulation results, process data, and other known parameters. These tests are used to make the preliminary numbers as close to the actual timing parameters as possible.

Final timing numbers are based on actual device operation and testing. These numbers reflect the actual performance of the device under worst-case voltage and junction temperature conditions.

<i>Table 5-15. Cyclone II Device Timing Model Status</i>		
Device	Preliminary	Final
EP2C5	✓	
EP2C8	✓	
EP2C20	✓	
EP2C35	✓	
EP2C50	✓	
EP2C70	✓	

PLL Timing Specifications

Table 5–16 describes the Cyclone II PLL specifications when operating within the commercial junction temperature range from 0° to 85° C.



PLL specifications under industrial temperature-range operating conditions are pending silicon characterization. The industrial junction temperature range specifications will be available upon completion of the PLL characterization across the industrial junction temperature range from -40 to 100° C.

Symbol	Parameter	Min	Max	Unit
f_{IN}	Input frequency (-6 speed grade)	11	311	MHz
	Input frequency (-7 speed grade)	11	270	MHz
	Input frequency (-8 speed grade)	11	240	MHz
f_{IN} DUTY	Input clock duty cycle	40	60	%
t_{IN} JITTER	Input clock period jitter		200	ps
f_{OUT_EXT} (external PLL clock output)	PLL output frequency (-6 speed grade)	15.625	(4)	MHz
	PLL output frequency (-7 speed grade)	15.625	(4)	MHz
	PLL output frequency (-8 speed grade)	15.625	(4)	MHz
f_{OUT} (to global clock)	PLL output frequency (-6 speed grade)	10	402.5	MHz
	PLL output frequency (-7 speed grade)	10	350	MHz
	PLL output frequency (-8 speed grade)	10	310	MHz
t_{OUT} DUTY	Duty cycle for external clock output (when set to 50%)	45	55	%
t_{JITTER} (2)	Period jitter for external clock output			ps
t_{LOCK}	Time required to lock from end of device configuration		1	ms
f_{VCO} (3)	PLL internal VCO operating range	300	1,000	MHz

Notes to Table 5–16:

- (1) These numbers are preliminary and pending silicon characterization.
- (2) The t_{JITTER} specification for the PLL [2 . . 1] _OUT pins are dependent on the I/O pins in its VCCIO bank, how many of them are switching outputs, how much they toggle, and whether or not they use programmable current strength.
- (3) If the design enables divide by 2, a 300- to 499-MHz internal VCO frequency is available.
- (4) This parameter is limited in Quartus II software by the I/O maximum frequency. The maximum I/O frequency is different for each I/O standard.

High Speed I/O Timing Specifications

Since LVDS, mini-LVDS, and RSDS data communication is source synchronous, timing analysis is different than other I/O standards. The high-speed I/O signal is based on skew between the data and the clock signal.

Designers should also consider board skew, cable skew, and clock jitter in their calculation. This section provides details on high-speed I/O standards timing parameters in Cyclone II devices.

Table 5–17 defines the parameters of the timing diagram shown in Figure 5–3.

<i>Table 5–17. High-Speed I/O Timing Definitions</i>		
Parameter	Symbol	Description
High-speed I/O data rate	HSIODR	High-speed receiver and transmitter input and output data rate.
Period	TUI	Time unit interval. TUI = 1/HSIODR.
Channel-to-channel skew	TCCS	The timing difference between the fastest and slowest output edges, including t_{CO} variation and clock skew. The clock is included in the TCCS measurement. TCCS = TUI – SW – (2 × RSKM)
Sampling window	SW	The period of time during which the data must be valid in order for you to capture it correctly. Sampling window is the sum of the setup time, hold time, and jitter. The window of $t_{SU} + t_H$ is expected to be centered in the sampling window. SW = TUI – TCCS – (2 × RSKM)
Receiver input skew margin	RSKM	RSKM is defined by the total margin left after accounting for the sampling window and TCCS. The RSKM equation is: RSKM = (TUI – SW – TCCS) / 2

Figure 5–3. High-Speed I/O Timing Diagram

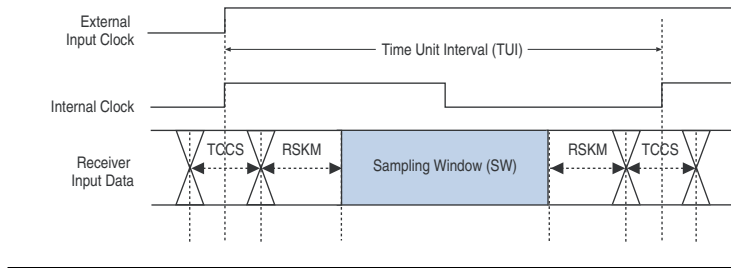
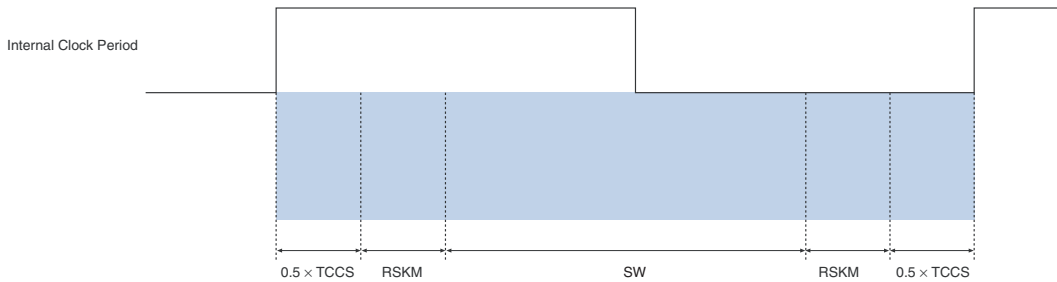

Figure 5–4 shows the high-speed I/O timing budget.

Figure 5–4. High-Speed I/O Timing Budget Note (1)



Note to Figure 5–4:

- (1) The equation for the high-speed I/O timing budget is:

$$\text{period} = TCCS + RSKM + SW + RSKM.$$

Table 5–18 shows the RSDS timing budget for Cyclone II devices at 170 Mbps. RSDS is supported for transmitting from Cyclone II devices. Cyclone II devices can not receive RSDS data because the devices are intended for applications where they will be driving display drivers.

Cyclone II devices support a maximum RSDS data rate of 170 Mbps using DDIO registers. The maximum internal clock frequency when designing for RSDS is 85 MHz.

Table 5–18. RSDS Transmitter Timing Specification

Symbol	Conditions	-6 Speed Grade			-7 Speed Grade			-8 Speed Grade			Unit
		Min	Typ	Max	Min	Typ	Max	Min	Typ	Max	
HSIODR	Using DDIO registers (1)	31.25		170	31.25		170	31.25		170	Mbps
Period		5.88			5.88			5.88			ns
TCCS				1.68			1.68			1.68	ns
SW	(2)			4.00			4.00			4.00	ns
RSKM	(3)			0.10			0.10			0.10	ns

Notes to Table 5–18:

- (1) The minimum data rate is limited by $2 \times f_N$ (minimum) for the PLL specifications shown in Table 5–16.
- (2) This is how large the sampling window (sum of t_{SU} , t_H , and t_{JITTER}) can be at the receiving device. The Cyclone II device is a transmitter only for the RSDS I/O standard.
- (3) The RSKM is assumed to be 100 ps for a calculated sampling window. RSKM is a system parameter determined by the designer.

In order to determine the transmitter timing requirements, RSDS receiver timing requirements on the other end of the link must be taken into consideration. RSDS receiver timing parameters are typically defined as t_{SU} and t_H requirements. Therefore, the transmitter timing parameter specifications are t_{CO} (minimum) and t_{CO} (maximum). Refer to Figure 5–4 for the timing budget.

The AC timing requirements for RSDS are shown in Figure 5–5.

Figure 5–5. RSDS Transmitter Clock to Data Relationship

Table 5–19 shows the mini-LVDS transmitter timing budget for Cyclone II devices at 170 Mbps. Cyclone II devices can not receive mini-LVDS data because the devices are intended for applications where they will be driving display drivers. A maximum mini-LVDS data rate of 170 Mbps is supported for Cyclone II devices using DDIO registers. The maximum internal clock frequency when designing for mini-LVDS is 85 MHz.

Table 5–19. mini-LVDS Transmitter Timing Specification

Symbol	Conditions	-6 Speed Grade			-7 Speed Grade			-8 Speed Grade			Unit
		Min	Typ	Max	Min	Typ	Max	Min	Typ	Max	
HSIODR	Using DDIO registers (1)	31.25		170	31.25		170	31.25		170	Mbps
Period		5.88			5.88			5.88			ns
TCCS				0.388			0.388			0.388	ns
SW	(2)			5.292			5.292			5.292	ns
RSKM	(3)			0.10			0.10			0.10	ns

Notes to Table 5–19:

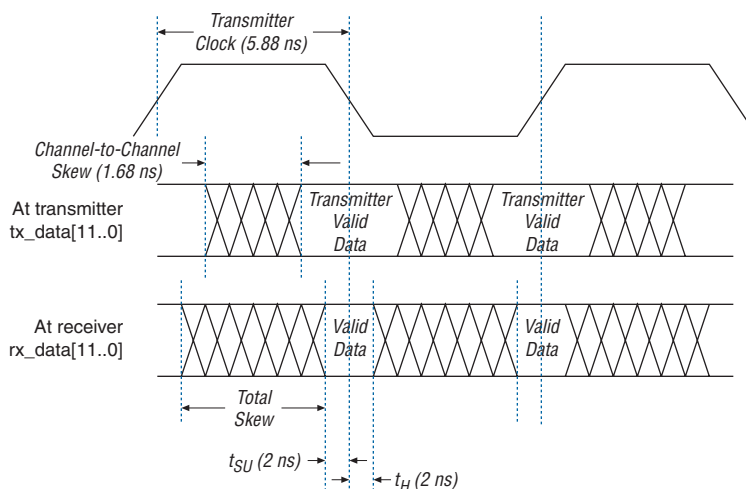
- (1) The minimum data rate is limited by $2 \times f_{IN}$ (minimum) for the PLL specifications shown in Table 5–16.
- (2) This is how large the sampling window (sum of t_{SU} , t_H , and t_{JITTER}) can be at the receiving device. The Cyclone II device is a transmitter only for mini-LVDS.
- (3) RSKM assumed to be 100 ps for calculated SW. RSKM is a system parameter determined by the designer.

In order to determine the transmitter timing requirements, mini-LVDS receiver timing requirements on the other end of the link must be taken into consideration. mini-LVDS receiver timing parameters are typically defined as t_{SU} and t_H requirements. Therefore, the transmitter timing parameter specifications are t_{CO} (minimum) and t_{CO} (maximum). Refer to [Figure 5-4](#) for the timing budget.

The AC timing requirements for mini-LVDS are shown in [Figure 5-6](#).

Figure 5-6. mini-LVDS Transmitter AC Timing Specification

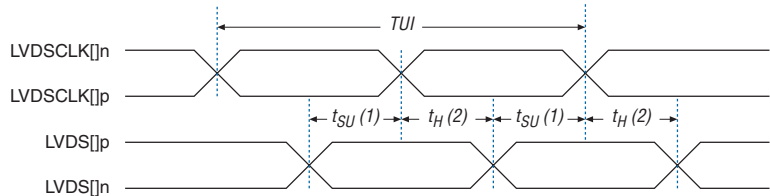

Notes to [Figure 5-6](#):

- (1) The data setup time, t_{SU} , is $0.225 \times TUI$.
- (2) The data hold time, t_H , is $0.225 \times TUI$.

Table 5–20 shows the LVDS timing budget for Cyclone II devices. Cyclone II devices support LVDS receivers at data rates up to 805 Mbps and LVDS transmitters at data rates up to 622 Mbps.

Symbol	Conditions	-6 Speed Grade			-7 Speed Grade			-8 Speed Grade			Unit
		Min	Typ	Max	Min	Typ	Max	Min	Typ	Max	
HSIODR (1)	10	156.25		622	156.25		622	156.25		530	Mbps
	8	125		622	125		622	125		530	Mbps
	7	125		622	125		622	125		530	Mbps
	4	62.5		622	62.5		622	62.5		530	Mbps
	2	31.25		622	31.25		622	31.25		530	Mbps
	1 (2)	15.625		311	15.625		311	15.625		265	Mbps
Period		1.608			1.608			1.886			ns
TCCS				200			200			230	ps
SW (3)		800			800			920			ps
RSKM				304			304			368	ps

Notes to Table 5–20:

- (1) The minimum data rate is limited by $2 \times f_N$ (minimum) for the PLL specifications shown in Table 5–16.
- (2) The PLL must divide down the input clock frequency to have the internal clock frequency meet the specification shown in Table 5–16.
- (3) These values assume 400 ps of PLL jitter for the SW parameter.

Software

Cyclone™ II devices are supported by the Altera® Quartus® II design software, which provides a comprehensive environment for system-on-a-programmable-chip (SOPC) design. The Quartus II software includes HDL and schematic design entry, compilation and logic synthesis, full simulation and advanced timing analysis, SignalTap® II logic analyzer, and device configuration. See the *Quartus II Handbook* for more information on the Quartus II software features.

The Quartus II software supports the Windows XP/2000/NT/98, Sun Solaris, Linux Red Hat v7.1 and HP-UX operating systems. It also supports seamless integration with industry-leading EDA tools through the NativeLink® interface.

Device Pin-Outs

Device pin-outs for Cyclone II devices are available on the Altera web site (www.altera.com). For more information contact Altera Applications.

Ordering Information

[Figure 6-1](#) describes the ordering codes for Cyclone II devices. For more information on a specific package, contact Altera Applications.

Figure 6–1. Cyclone II Device Packaging Ordering Information

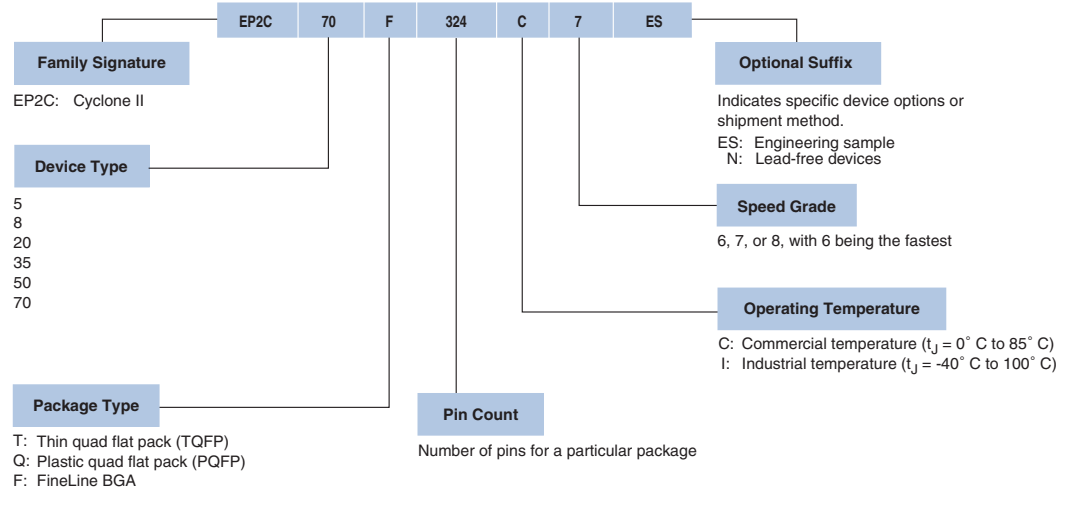

This section provides information on the phase-locked loops (PLLs). Cyclone™ II PLLs offer general-purpose clock management with multiplication and phase shifting and also have the ability to drive off chip to control system-level clock networks. This section contains detailed information on the features, the interconnections to the logic array and off chip, and the specifications for Cyclone II PLLs.

This section includes the following chapter:

- [Chapter 7, PLLs in Cyclone II Devices](#)

Revision History

The table below shows the revision history for [Chapter 7](#).

Chapter(s)	Date / Version	Changes Made
7	November 2004, v1.1	Updated "Introduction" section.
	June 2004, v1.0	Added document to the Cyclone II Device Handbook.

Introduction

Cyclone™ II devices have up to four phase-locked loops (PLLs) that provide robust clock management and synthesis for device clock management, external system clock management, and I/O interfaces. Cyclone II PLLs are versatile and can be used as a zero delay buffer, a jitter attenuator, a low skew fan out buffer, or a frequency synthesizer.

Each Cyclone II device has up to four PLLs, supporting advanced capabilities such as clock switchover and programmable bandwidth. These PLLs offer clock multiplication and division, phase shifting, and programmable duty cycle and can be used to minimize clock delay and clock skew, and to reduce or adjust clock-to-out (t_{CO}) and set-up (t_{SU}) times.

Cyclone II devices also support a power-down mode where unused clock networks can be turned off. The Altera® Quartus® II software enables the PLLs and their features without requiring any external devices.



Cyclone II PLLs are designed to operate in the commercial temperature range (0° to 85° C). The industrial junction temperature range specifications will be available upon completion of the PLL characterization across the industrial temperature range from -40 to 100° C.

Table 7-1 shows the PLLs available in each Cyclone II device.

Device	PLL1	PLL2	PLL3	PLL4
EP2C5	✓	✓		
EP2C8	✓	✓		
EP2C20	✓	✓	✓	✓
EP2C35	✓	✓	✓	✓
EP2C50	✓	✓	✓	✓
EP2C70	✓	✓	✓	✓

Table 7-2 provides an overview of the Cyclone II PLL features.

Table 7-2. Cyclone II PLL Features	
Feature	Description
Clock multiplication and division	$m / (n \times \text{post-scale counter})$ (1)
Phase shift	Down to 125-ps increments (2), (3)
Programmable duty cycle	✓
Number of internal clock outputs	Up to three per PLL (4)
Number of external clock outputs	One per PLL (4)
Locked port can feed logic array	✓
PLL clock outputs can feed logic array	✓
Programmable bandwidth	✓
Manual clock switchover	✓
Gated lock	✓

Notes to Table 7-2:

- (1) m and post-scale counter values range from 1 to 32. n ranges from 1 to 4.
- (2) The smallest phase shift is determined by the voltage control oscillator (VCO) period divided by 8.
- (3) For degree increments, Cyclone II devices can shift output frequencies in increments of at least 45°. Smaller degree increments are possible depending on the VCO frequency.
- (4) The Cyclone II PLL has three output counters that drive the global clock network. One of these output counters (c2) can also drive a dedicated external I/O pin (single ended or differential). This counter output can also drive the external clock output (PLL<#>_OUT) and internal global clock network at the same time.

Cyclone II PLL Hardware Overview

Cyclone II devices contain up to four PLLs that are arranged in the four corners of the Cyclone II device as shown in Figure 7-1, which shows a top-level diagram of the Cyclone II device and the PLL locations.

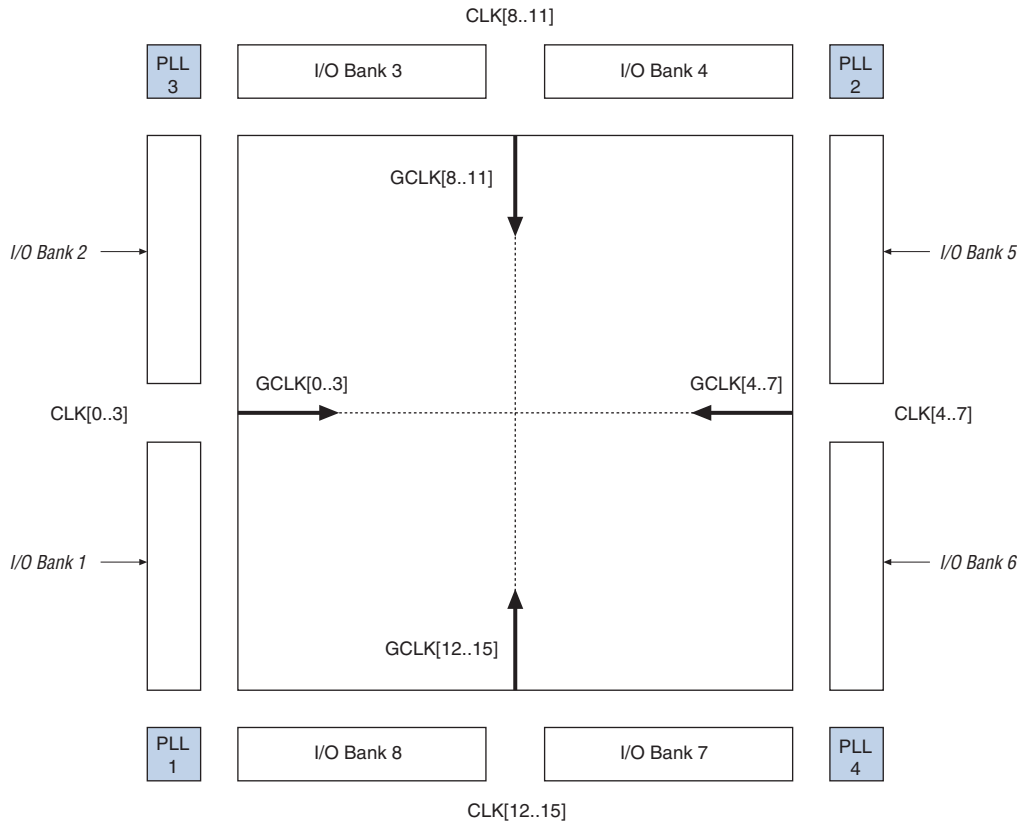
Figure 7-1. Cyclone II Device PLL Locations *Note (1)***Note to Figure 7-1:**

- (1) This figure shows the PLL and clock inputs in the EP2C20 through EP2C70 devices. The EP2C5 and EP2C8 devices only have eight global clocks (CLK[0..3] and CLK[4..7]) and PLLs 1 and 2.

The main purpose of a PLL is to synchronize the phase and frequency of the VCO to an input reference clock. There are a number of components that comprise a PLL to achieve this phase alignment.

The PLL compares the rising edge of the reference input clock to a feedback clock using a phase-frequency detector (PFD). The PFD produces an up or down signal that determines whether the VCO needs to operate at a higher or lower frequency. The PFD output is applied to the charge pump and loop filter, which produces a control voltage for setting the frequency of the VCO. If the PFD transitions the up signal high, then the VCO frequency will increase. If the PFD transitions the down signal high, then the VCO frequency will decrease.

The loop filter converts these up and down signals to a voltage that is used to bias the VCO. If the charge pump receives a logic high on the up signal, current is driven into the loop filter. If the charge pump receives a logic high on the down signal, current is drawn from the loop filter. The loop filter filters out glitches from the charge pump and prevents voltage over-shoot, which minimizes the jitter on the VCO.

The voltage from the charge pump determines how fast the VCO operates. The VCO is implemented as an eight-stage differential ring oscillator. A divide counter, m , is inserted in the feedback loop to increase the VCO frequency above the input reference frequency, making the VCO frequency $f_{VCO} = m \times f_{REF}$. Therefore, the feedback clock, f_{FB} , applied to one input of the PFD, is locked to the input reference clock, f_{REF} (f_{IN}/n), applied to the other input of the PFD.

The VCO output can feed up to three post-scale counters (c0, c1, and c2). These post-scale counters allow a number of harmonically related frequencies to be produced by the PLL.

Additionally, Cyclone II PLLs have internal delay elements to compensate for routing on the global clock networks and I/O buffers. These internal delays are fixed and not accessible to the user.

Figure 7–2 shows a simplified block diagram of the major components of a Cyclone II device PLL.

Figure 7-2. Cyclone II PLL Block Diagram

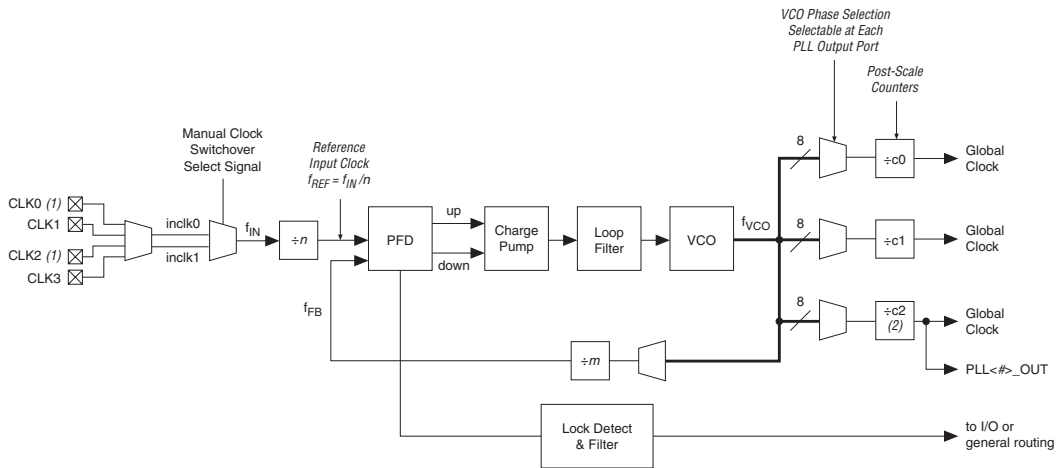
**Notes to Figure 7-2:**

- (1) This input can be single-ended or differential. If you are using a differential I/O standard, then the design uses two clock pins. LVDS input is supported via the secondary function of the dedicated clock pins. For example, the CLK0 pin's secondary function is LVDSCLK1p and the CLK1 pin's secondary function is LVDSCLK1n. Figure 7-2 shows the possible clock input connections to PLL 1.
- (2) This counter output is shared between a dedicated external clock output (PLL<#>_OUT) and the global clock network.

The Cyclone II PLL supports up to three global clock outputs and one dedicated external clock output. The output frequency to the global clock network or dedicated external clock output is determined by using the following equation:

$$f_{\text{global/external}} = f_{\text{IN}} \frac{m}{n \times C}$$

f_{IN} is the clock input to the PLL and C is the setting on the $c0$, $c1$, or $c2$ counter.

The VCO frequency is determined in all cases by using the following equation:

$$f_{\text{VCO}} = f_{\text{IN}} \frac{m}{n}$$

The VCO frequency is a critical parameter that must be between 300 and 1,000 MHz to ensure proper operation of the PLL. The Quartus II software automatically sets the VCO frequency within the recommended range based on the clock output and phase-shift requirements in your design.

PLL Reference Clock Generation

In Cyclone II devices, up to four clock pins can drive the PLL, as shown in [Figure 7-14 on page 7-29](#). The multiplexer output feeds the PLL reference clock input. The PLL has internal delay elements that compensate for the clock delay from the input pin to the clock input port of the PLL.

[Table 7-3](#) shows the clock input pin connections to the PLLs in the Cyclone II device.

Device	PLL 1		PLL 2		PLL 3		PLL 4	
	CLK0 CLK1	CLK2 CLK3	CLK4 CLK5	CLK6 CLK7	CLK8 CLK9	CLK10 CLK11	CLK12 CLK13	CLK14 CLK15
EP2C5	✓	✓	✓	✓				
EP2C8	✓	✓	✓	✓				
EP2C20	✓	✓	✓	✓	✓	✓	✓	✓
EP2C35	✓	✓	✓	✓	✓	✓	✓	✓
EP2C50	✓	✓	✓	✓	✓	✓	✓	✓
EP2C70	✓	✓	✓	✓	✓	✓	✓	✓

Each PLL can be fed by one of four single-ended or two differential clock input pins. For example, PLL 1 can be fed by CLK [3 . . 0] when using a single-ended I/O standard. When your design uses a differential I/O standard, these same clock pins have a secondary function as LVDSCLK [2 . . 1] p and LVDSCLK [2 . . 1] n pins. When using differential clocks, the CLK0 pin's secondary function is LVDSCLK1p, the CLK1 pin's secondary function is LVDSCLK1n, etc.

Software Overview

You can use the `altpll` megafunction in the Quartus II software to enable Cyclone II PLLs. [Figure 7-3](#) shows the available ports in Cyclone II PLLs and their sources and destinations. The `c0` and `c1`

counters feed the internal global clock networks and the c2 counter can feed the global clock network and a dedicated external clock output pin (PLL<#>_OUT) at the same time.

Figure 7-3. Cyclone II PLL Signals

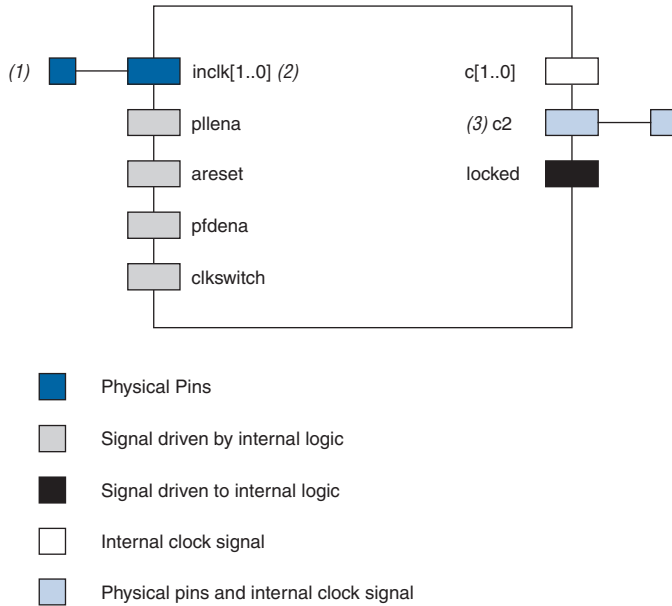

Notes to Figure 7-3:

- (1) These signals can be assigned to either a single-ended or differential I/O standard.
- (2) The `inclk` must be driven by one of two dedicated clock input pins.
- (3) This counter output can drive both a dedicated external clock output (PLL<#>_OUT) and the global clock network.

Tables 7-4 and 7-5 describe the Cyclone II PLL input and output ports.

Table 7-4. PLL Input Signals			
Port	Description	Source	Destination
<code>inclk[1..0]</code>	Primary and secondary clock inputs to the PLL.	Dedicated clock input pins	n counter
<code>pllena</code>	<code>pllena</code> is an active high signal that acts as an enable and reset signal for the PLL. It can be used for enabling or disabling each PLL. When <code>pllena</code> transitions low, the PLL clock output ports are driven to GND and the PLL loses lock. Once <code>pllena</code> transitions high again, the lock process will begin and the PLL will re-synchronize to its input reference clock. The <code>pllena</code> port can be driven by an LE output or any general-purpose I/O pin.	Logic array or input pin	PLL control signal
<code>areset</code>	<code>areset</code> is an active high signal that resets all PLL counters to their initial values. When this signal is driven high the PLL will reset its counters, clear the PLL outputs and lose lock. Once this signal is driven low again, the lock process will begin and the PLL will re-synchronize to its input reference clock. The <code>areset</code> port can be driven by an LE output or any general-purpose I/O pin.	Logic array or input pin	PLL control signal
<code>pfdena</code>	<code>pfdena</code> is an active high signal that enables or disables the up/down output signals from the PFD. When <code>pfdena</code> is driven low, the PFD is disabled, while the VCO continues to operate. The PLL clock outputs continue to toggle regardless of the input clock, but may experience some long-term drift. Because the output clock frequency does not change for some time, you can use the <code>pfdena</code> port as a shutdown or cleanup function when a reliable input clock is no longer available. The <code>pfdena</code> port can be driven by an LE output or any general-purpose I/O pin.	Logic array or input pin	PFD
<code>clkswitch</code>	<code>clkswitch</code> is an active high switchover signal used to initiate manual clock switchover.	Logic array or input pin	PLL control signal

Table 7–5. PLL Output signals

Port	Description	Source	Destination
c[1..0]	PLL clock outputs driving the internal global clock network.	PLL post-scale counter	Global clock network
c2	PLL clock output that can drive the internal global clock network and/or the external clock output pin (PLL<#>_OUT).	PLL post-scale counter	Global clock network or external I/O pin
Locked	Gives the status of the PLL lock. When the PLL is locked, this port drives V _{CC} . When the PLL is out of lock, this port drives GND. The locked port may pulse high and low during the PLL lock process.	PLL lock detect circuit	Logic array or output pin

Table 7–6 shows a list of I/O standards supported in Cyclone II device PLLs.

Table 7–6. I/O Standards Supported for Cyclone II PLLs (Part 1 of 2)

I/O Standard	Input	Output	
	inclk	lock	pll_out
LVTTTL (3.3, 2.5, and 1.8 V)	✓	✓	✓
LVC MOS (3.3, 2.5, 1.8, and 1.5 V)	✓	✓	✓
3.3-V PCI	✓	✓	✓
3.3-V PCI-X (1)	✓	✓	✓
LVPECL	✓		
LVDS	✓	✓	✓
1.5 and 1.8 V differential HSTL class I and class II	✓		✓ (2)
1.8 and 2.5 V differential SSTL class I and class II	✓		✓ (2)
1.5-V HSTL class I	✓	✓	✓
1.5-V HSTL class II (3)	✓	✓	✓
1.8-V HSTL class I	✓	✓	✓
1.8-V HSTL class II (3)	✓	✓	✓
SSTL-18 class I	✓	✓	✓
SSTL-18 class II (3)	✓	✓	✓
SSTL-25 class I	✓	✓	✓

Table 7–6. I/O Standards Supported for Cyclone II PLLs (Part 2 of 2)

I/O Standard	Input	Output	
	inclk	lock	pll_out
SSTL-25 class II	✓	✓	✓
RSDS/mini-LVDS	✓	✓	✓

Notes to Table 7–6:

- (1) The PCI-X I/O standard is supported only on side I/O pins.
- (2) Differential SSTL and HSTL outputs are only supported on the PLL<#>_OUT pins.
- (3) These I/O standards are only supported on top and bottom I/O pins.

Clock Feedback Modes

Cyclone II PLLs support three clock feedback modes: normal mode, zero delay buffer mode, and no compensation mode. Cyclone II PLLs do not have support for external feedback mode. All the supported clock feedback modes allow for multiplication and division, phase shifting, and programmable duty cycle. The phase relationships shown in the waveforms in Figures 7–4 through 7–6 are for the default (zero degree) phase shift setting. Changing the phase-shift setting will change the relationships between the output clocks from the PLL.

Normal Mode

In normal mode, the PLL phase-aligns the input reference clock with the clock signal at the ports of the registers in the logic array I/O registers to compensate for the internal global clock network delay. Use the `altpll` megafunction in the Quartus II software to define which internal clock output from the PLL (c0, c1, or c2) to compensate for.

If an external clock output pin (PLL<#>_OUT) is used in this mode, there will be a phase shift with respect to the clock input pin. Similarly, if the internal PLL clock outputs are used to drive general-purpose I/O pins, there will be a phase shift with respect to the clock input pin.

Figure 7–4 shows an example waveform of the PLL clocks' phase relationship in this mode.

Figure 7–4. Phase Relationship between Cyclone II PLL Clocks in Normal Mode

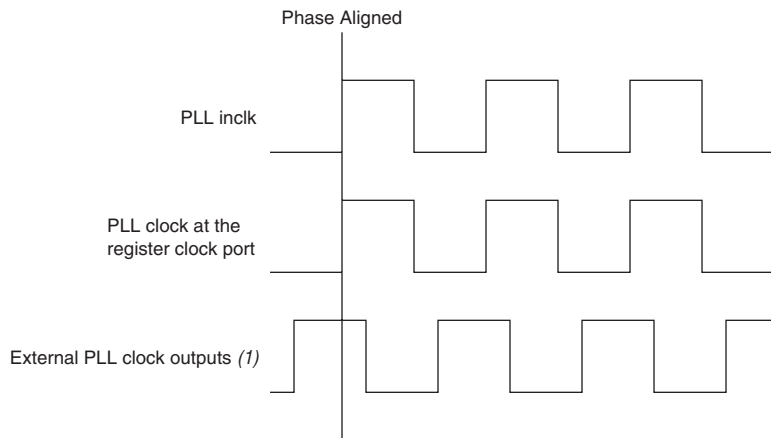

Note to Figure 7–4:

(1) The external clock output can lead or lag the PLL clock signals.

Zero Delay Buffer Mode

In zero delay buffer mode, the clock signal on the PLL external clock output pin (PLL<#>_OUT), fed by the c2 counter, is phase-aligned with the PLL input clock for zero delay. If the c[1..0] ports drive internal clock ports, there will be a phase shift with respect to the input clock pin. Figure 7–5 shows an example waveform of the PLL clocks' phase relationship in this mode.

Figure 7–5. Phase Relationship between Cyclone II PLL Clocks in Zero Delay Buffer Mode

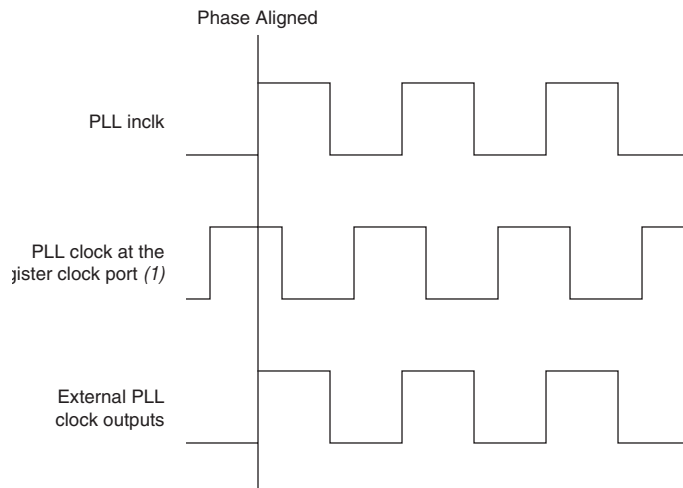

Note to Figure 7–5:

- (1) The internal clock output(s) can lead or lag the external PLL clock output (PLL<#>_OUT) signals.



Altera recommends using the same I/O standard on the input and output clocks when using the Cyclone II PLL in zero delay buffer mode.

No Compensation Mode

In no compensation mode, the PLL will not compensate for any clock networks, which leads to better jitter performance. Since the clock feedback into the PFD does not pass through as much circuitry, both the PLL internal clock outputs and external clock outputs will be phase shifted with respect to the PLL clock input. Figure 7–6 shows an example waveform of the PLL clocks' phase relationship in this mode.

Figure 7–6. Phase Relationship between Cyclone II PLL Clocks in No Compensation Mode

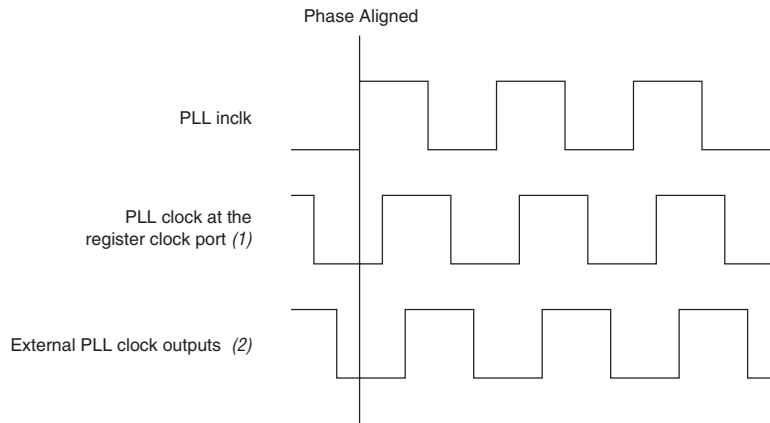

Notes to Figure 7–6:

- (1) Internal clocks fed by the PLL will be in phase with each other.
- (2) The external clock outputs can lead or lag the PLL internal clocks.

Hardware Features

Cyclone II device PLLs support a number of features for general-purpose clock management. This section discusses clock multiplication and division implementation, phase-shifting implementation, PLL lock circuits, and programmable bandwidth.

Clock Multiplication Division

Cyclone II device PLLs provide clock synthesis for PLL output ports using $m/(n \times \text{post-scale})$ scaling factors. Every PLL has one pre-scale divider, n , with a range of 1 to 4 and one multiply counter, m , with a range of 1 to 32. The input clock, f_{IN} , is divided by a pre-scale counter, n , to produce the input reference clock, f_{REF} to the PFD. This input reference clock, f_{REF} is then multiplied by the m feedback factor. The control loop drives the VCO frequency to match $f_{\text{IN}} \times (m/n)$. The equations for these frequencies are:

$$f_{\text{REF}} = \frac{f_{\text{IN}}}{n}$$

$$f_{\text{VCO}} = f_{\text{REF}} \times m = f_{\text{IN}} \frac{m}{n}$$

Each output port has a unique post-scale counter to divide down the high-frequency VCO. There are three post-scale counters (c0, c1, and c2), which range from 1 to 32. The following equations show the frequencies for the three post-scale counters:

$$f_{C0} = \frac{f_{VCO}}{C0} = f_{IN} \frac{m}{n \times C0}$$

$$f_{C1} = \frac{f_{VCO}}{C1} = f_{IN} \frac{m}{n \times C1}$$

$$f_{C2} = \frac{f_{VCO}}{C2} = f_{IN} \frac{m}{n \times C2}$$

All three output counters can drive the global clock network. The c2 output counter can also drive a dedicated external I/O pin (single ended or differential). This counter output can drive a dedicated external clock output pin (PLL<#>_OUT) and the global clock network at the same time.

For multiple PLL outputs with different frequencies, the VCO is set to the least common multiple of the output frequencies that meets the VCO frequency specifications. Then, the post-scale counters scale down the VCO frequency for each PLL clock output port. For example, if clock output frequencies required from one PLL are 33 and 66 MHz, the VCO is set to 330 MHz (the least common multiple in the VCO's range).

Programmable Duty Cycle

The programmable duty cycle feature allows you to set the PLL clock output duty cycles. The duty cycle is the ratio of the clock output high and low time to the total clock cycle time, expressed as a percentage of high time. This feature is supported on all three PLL post-scale counters, c0, c1, and c2, and when using all clock feedback modes.

The duty cycle is set by using a low- and high-time count setting for the post-scale counters. The Quartus II software uses the input frequency and target multiply/divide ratio to select the post-scale counter. The granularity of the duty cycle is determined by the post-scale counter value chosen on a PLL clock output and is defined as $50\% \div$ post-scale counter value. For example, if the post-scale counter value is 3, then the allowable duty cycle precision would be $50\% \div 3 = 16.67\%$. Because the `altpll` megafunction does not accept non-integer values for the duty cycle values, the allowable duty cycles are 17% 33% 50% and 67%. For example, if the c0 counter is 10, then steps of 5% are possible for duty cycle choices between 5 to 90%.

Phase-Shifting Implementation

Cyclone II devices use fine or coarse phase shifts for clock delays because they are more efficient than delay elements and are independent of process, voltage, and temperature.

Phase shift is implemented by using a combination of the VCO phase output and the counter starting time. The VCO phase taps and counter starting time are independent of process, voltage, and temperature. The VCO phase taps allow you to phase shift the Cyclone II PLL output clocks with fine resolution. The counter starting time allows you to phase shift the Cyclone II PLL output clocks with coarse resolution.

Fine-resolution phase shifting is implemented using any of the eight VCO phases for the output counters ($c[2..0]$) or the feedback counter (m) reference clock. This provides the finest resolution for phase shift. The minimum delay time that may be inserted using this method is defined by the equation:

$$\Delta t_{\text{FINE}} = \frac{1}{8} t_{\text{VCO}} = \frac{1}{8 \times f_{\text{VCO}}} = \frac{n}{8 \times m \times f_{\text{IN}}}$$

f_{IN} is input reference clock frequency.

For example, if f_{IN} is 100 MHz, n is 1 and m is 8, then f_{VCO} is 800 MHz and Δt is 156.25 ps. This delay time is defined by the PLL operating frequency which is governed by the reference clock and the counter settings.

The second way to implement phase shifts is by delaying the start of the m and post-scale counters for a predetermined number of counter clocks. This delay time may be expressed as:

$$\Delta t_{\text{COARSE}} = \frac{S - 1}{f_{\text{VCO}}} = \frac{(S - 1) \times n}{m \times f_{\text{IN}}}$$

where S is the value set for the counter starting time. The counter starting time is called the **Initial** setting in the PLL Usage section of the compilation report in the Quartus II software.

Figure 7-7 shows an example of delay insertion using these two methods. The eight phases from the VCO are shown and labeled for reference. For this example, `OUTCLK0` is based off the 0° phase from the VCO and has the S value for the counter set to 1. It is divided by 4 (two VCO clocks for high time and two VCO clocks for low time). `OUTCLK1` is based off the 135° phase tap from the VCO and also has the S value for the counter set to 1. It is also divided by 4. In this case, the two clocks are offset by three

Δt_{FINE} periods. OUTCLK2 is based off the 0° phase from the VCO but has the S value for the counter set to 3. This creates a delay of two Δt_{COARSE} periods.

Figure 7–7. Cyclone II PLL Phase Shifting using VCO Phase Output & Counter Delay Time

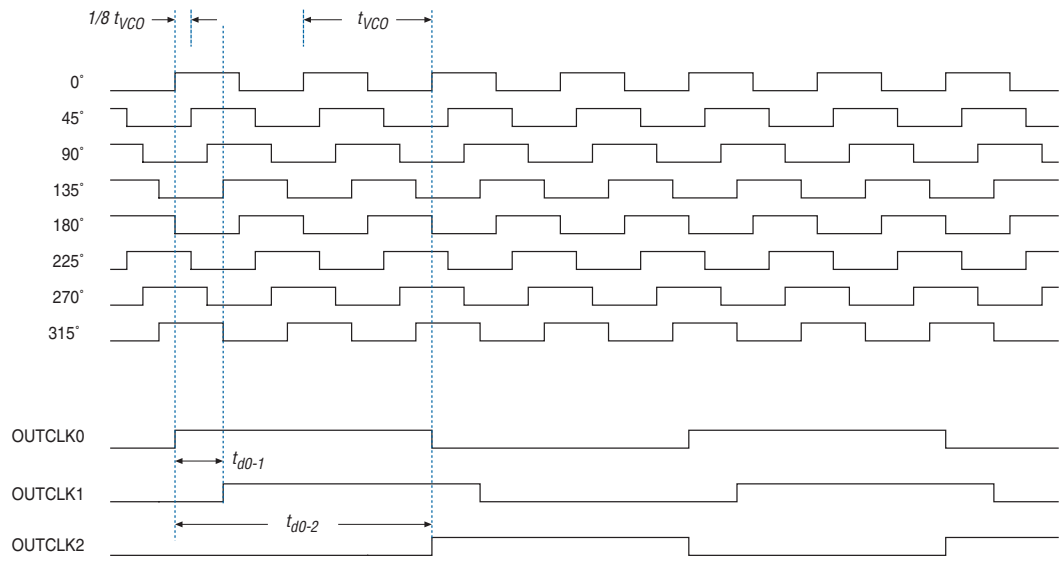

Control Signals

The four control signals in Cyclone II PLLs (`pllena`, `areset`, `pfdena`, and `locked`) control PLL operation.

pllena

The PLL enable signal, `pllena`, enables and disables the PLL. The `pllena` signal is an active-high signal. When `pllena` is low, the PLL clock output ports are driven by GND and the PLL loses lock. When `pllena` transitions high, the PLL relocks and resynchronizes to the input clock. In Cyclone II devices, the `pllena` port can be fed by an LE output or any general-purpose I/O pin. There is no dedicated `pllena` pin. This increases flexibility since each PLL can have its own `pllena` control circuitry or all PLLs can share the same `pllena` circuitry. The `pllena` signal is optional. When it is not enabled in the Quartus II software, the port is internally tied to V_{CC} .

areset

The PLL *areset* signal is the reset and resynchronization input for each PLL. The *areset* signal is an active high signal and, when driven high, the PLL counters reset, clearing the PLL output and causing the PLL to lose lock. The clock outputs from the PLL are driven to ground as long as *areset* is active. When *areset* transitions low, the PLL will resynchronize to its input clock as the PLL relocks. If the target VCO frequency is below this nominal frequency, then the PLL clock output frequency will start at a higher value than desired during the lock process. In this case, Altera recommends monitoring the gated *locked* signal to ensure the PLL is fully in lock before enabling the clock outputs from the PLL. The Cyclone II device can drive this PLL input signal from LEs or any general-purpose I/O pin. The *areset* signal is optional. When it is not enabled in the Quartus II software, the port is internally tied to GND.

pfdena

The *pfdena* signal is an active high signal that controls the PFD output in the PLL with a programmable gate. If you disable the PFD by transitioning *pfdena* low, the VCO will operate at its last set control voltage and frequency value with some long-term drift to a lower frequency. Even though the PLL clock outputs continue to toggle regardless of the input clock, the PLL could lose lock. The system will continue running when the PLL goes out of lock or if the input clock is disabled. By maintaining the current frequency, the system has time to store its current settings before shutting down. If the *pfdena* signal transitions high, the PLL will relock and resynchronize to the input clock. The *pfdena* input signal can be driven by any general-purpose I/O pin or from LEs. This signal is optional. When it is not enabled in the Quartus II software, the port is internally tied to V_{CC} .

locked

When the *locked* port output is a logic high level, this indicates a stable PLL clock output in phase with the PLL reference input clock. The *locked* port may toggle as the PLL begins tracking the reference clock. The *locked* port of the PLL can feed any general-purpose I/O pin or LEs. The *locked* signal is optional, but is useful in monitoring the PLL lock process.

The *locked* output indicates that the PLL has locked onto the reference clock. You may need to gate the *locked* signal for use as a system-control signal. Either a gated *locked* signal or an ungated *locked* signal from the *locked* port can drive the logic array or an output pin. Cyclone II PLLs include a programmable counter that holds the *locked* signal low

for a user-selected number of input clock transitions. This allows the PLL to lock before transitioning the `locked` signal high. You can use the Quartus II software to set the 20-bit counter value. The device resets and enables both the counter and the PLL simultaneously upon power-up and/or the assertion of the `pllenable` signal. To ensure correct lock circuit operation, and to ensure that the output clocks have the correct phase relationship with respect to the input clock, Altera recommends that the input clock be running before the Cyclone II device is configured.

Figure 7–8 shows the timing waveform for `LOCKED` and gated `LOCKED` signals.

Figure 7–8. Timing Waveform for `LOCKED` & Gated `LOCKED` Signals

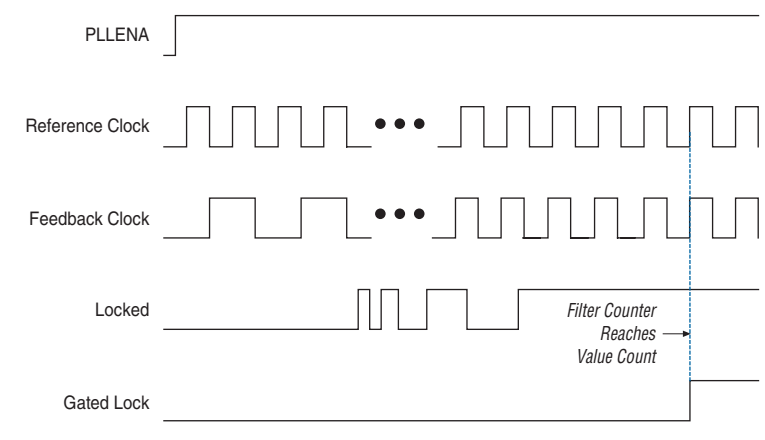

Manual Clock Switchover

The Cyclone II PLLs support manual switchover of the reference clock through internal logic. This enables you to switch between two reference input clocks. Use this feature for a dual clock domain application such as in a system that turns on the redundant clock if the primary clock stops running.

Figure 7–9 shows how the PLL input clock (f_{IN}) is generated from one of four possible clock sources. The first stage multiplexing consists of two dedicated multiplexers that generate two single-ended or two differential clocks from four dedicated clock pins. These clock signals are then multiplexed to generate f_{IN} by using another dedicated 2-to-1 multiplexer. The first stage multiplexers are controlled by configuration bit settings in the configuration file generated by the Quartus II software, while the second stage multiplexer is either controlled by the

configuration bit settings or logic array signal to allow the f_{IN} to be controlled dynamically. This allows the implementation of a manual clock switchover circuit where the PLL reference clock can be switched during user mode for applications that requires clock redundancy.

Figure 7–9. Cyclone II PLL Input Clock Generation

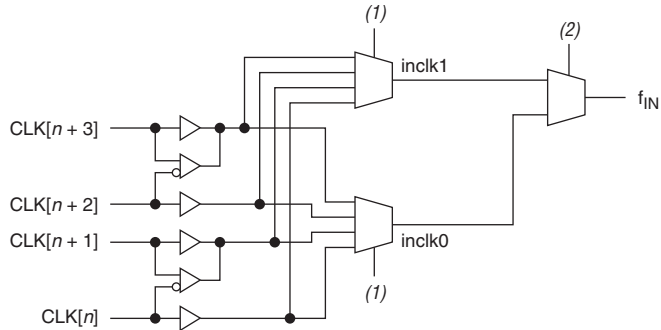

Notes to Figure 7–9:

- (1) This select line is set through the configuration file.
- (2) This select line can either be set through the configuration file or it can be dynamically set in user mode when using the manual switchover feature.

Programmable Bandwidth

Cyclone II PLLs provide advanced control of PLL bandwidth using the programmable characteristics of the PLL loop, including loop filter and charge pump.

Background

PLL bandwidth is the measure of the PLL's ability to track the input clock and jitter. It is determined by the 3-dB frequency of the closed-loop gain in the PLL or approximately the unity gain point for open-loop PLL response. As Figure 7–10 shows, these points correspond to approximately the same frequency.

Figure 7-10. Open- & Closed-Loop Response Bode Plots

Open-Loop Response Bode Plot

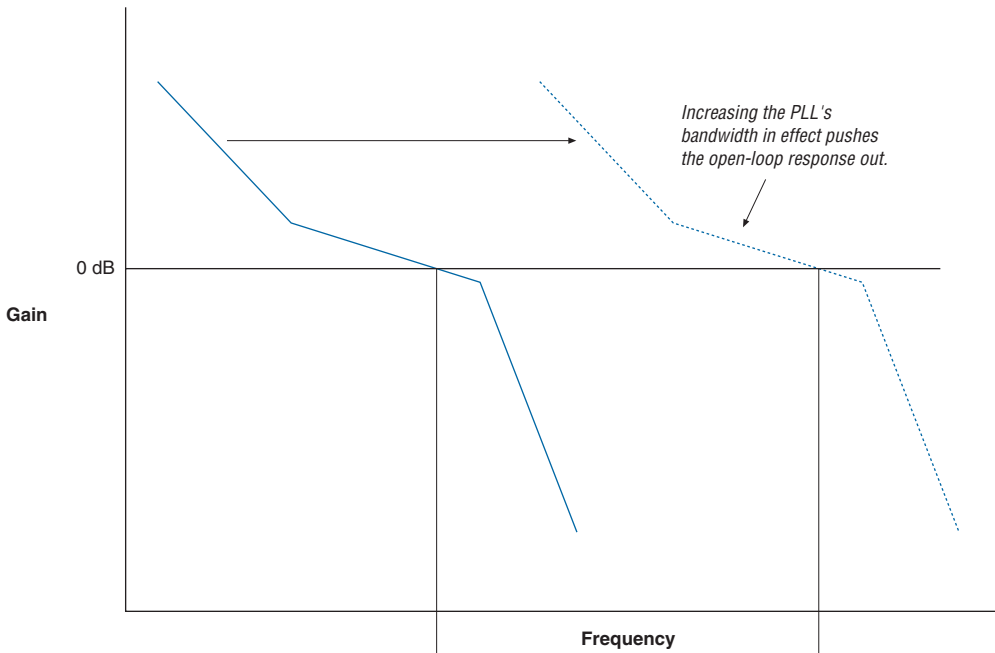

Closed-Loop Response Bode Plot

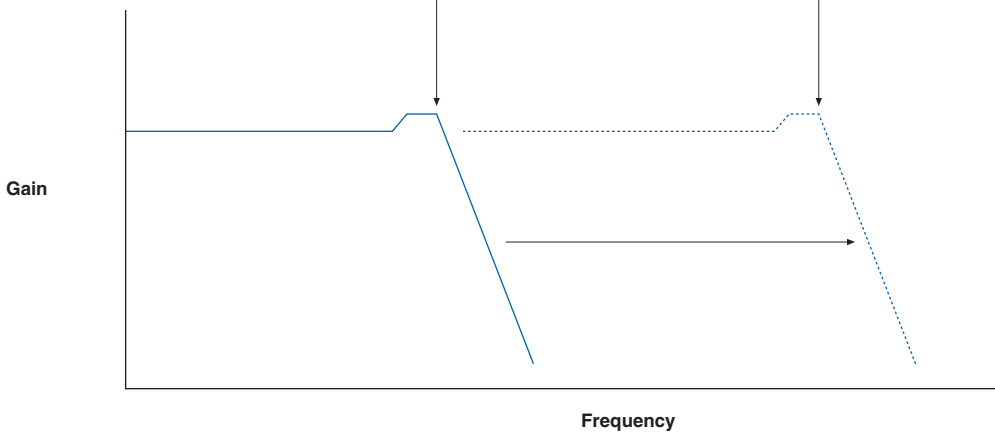

A high-bandwidth PLL provides a fast lock time and tracks jitter on the reference clock source, passing it through to the PLL clock output. A low-bandwidth PLL filters out reference clock jitter, but increases lock time. Cyclone II device PLLs allow you to control the bandwidth over a finite range to customize the PLL characteristics for a particular application. Applications that require clock switchover (such as TDMA, frequency hopping wireless, and redundant clocking) can benefit from the Cyclone II PLL's programmable bandwidth feature.

The bandwidth and stability of such a system is determined by a number of factors, including the charge pump current, the loop filter resistor value, the high-frequency capacitor value (in the loop filter), and the m -counter value. You can use the Quartus II software to control these factors and to set the bandwidth to the desired value within a given range.

You can set the bandwidth to the appropriate value to balance the need for jitter filtering and lock time. Figures 7–11 and 7–12 show the output of a low- and high-bandwidth PLL, respectively, as it locks onto the input clock.

Figure 7–11. Low-Bandwidth PLL Lock Time

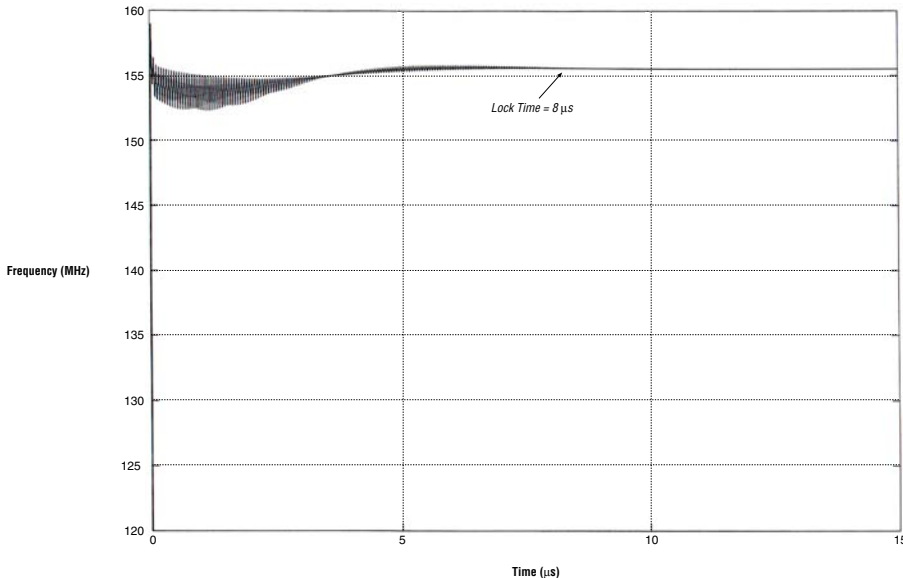
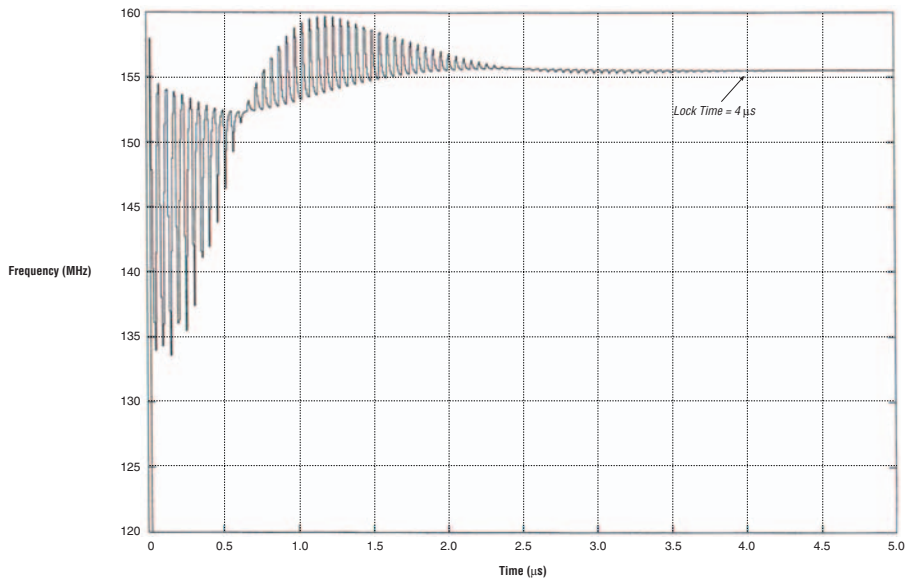

Figure 7–12. High-Bandwidth PLL Lock Time



A high-bandwidth PLL may benefit a system with two cascaded PLLs. If the first PLL uses spread spectrum (as user-induced jitter), the second PLL needs a high bandwidth so it can track the jitter that is feeding it. A low-bandwidth PLL may, in this case, lose lock due to the spread-spectrum-induced jitter on the input clock.

A low-bandwidth PLL may benefit a system using clock switchover. When the clock switchover happens, the PLL input temporarily stops. A low-bandwidth PLL would react more slowly to changes to its input clock and take longer to drift to a lower frequency (caused by the input stopping) than a high-bandwidth PLL. This gives users some time to save their current settings before switching to the new clock frequency.

Implementation

Traditionally, external components, such as the VCO or loop filter, control a PLL's bandwidth. Most loop filters are made up of passive components, such as resistors and capacitors, that take up unnecessary board space and increase cost. With Cyclone II device PLLs, all the components are contained within the device to increase performance and decrease cost.

Cyclone II device PLLs implement programmable bandwidth by changing the charge-pump current and loop-filter resistor (R) and high-frequency capacitor (C_h) values (see Table 7-7). The Cyclone II device PLL bandwidth range is pending device characterization.

The charge-pump current directly affects the PLL bandwidth. The higher the charge-pump current, the higher the PLL bandwidth. You can choose from a fixed set of values for the charge-pump current. Figure 7-13 shows the charge pump and the loop filter components that affect the bandwidth of a PLL.

Figure 7-13. Loop Filter Programmable Components

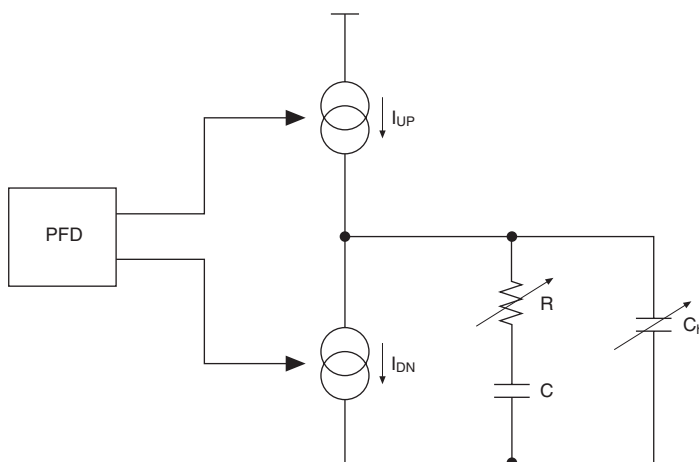

Software Support

The Quartus II software provides two levels of programmable bandwidth control.

Megafunction-Based Bandwidth Setting

The first level of programmable bandwidth allows you to enter a value for the desired bandwidth directly into the Quartus II software using the `altpll` megafunction. You can also set the bandwidth parameter in the `altpll` megafunction to low, medium or high values. The Quartus II software selects the best bandwidth parameters available to match your bandwidth request. If the bandwidth setting requested is not available, the Quartus II software selects the closest achievable value.

Advanced Bandwidth Setting

An advanced level of control is also possible using advanced loop-filter parameters. You can precisely control the bandwidth of the PLL by selectively changing the charge-pump current, loop-filter resistor value, and the loop-filter (high frequency) capacitor value. The parameters for these changes are: `charge_pump_current`, `loop_filter_r`, and `loop_filter_c`. You can enter these parameters directly into the `altpll` megafunction-generated wrapper (`.v`, `.vhdl`, or `.tdf`) file. Refer to the *altpll Megafunction User Guide* for more details on these parameters.

Each parameter supports the specific range of values listed in [Table 7-7](#).

Parameter	Values
Resistor values (k Ω)	1, 1.5, 2, 2.5
High-frequency capacitance values (pF)	5, 10, 15, 20
Charge pump current settings (μ A)	10, 20, 30, 40, 50, 60, 70, 80

Note to Table 7-7:

(1) These values are preliminary.

PLL Specifications

See the *DC & Switching Characteristics* chapter in Volume 1 of the *Cyclone II Device Handbook* for information on PLL timing specifications.

Clocking

Cyclone II devices provide up to 16 dedicated clock pins (`CLK[15..0]`) that can drive the global clock networks. The smaller Cyclone II devices (EP2C5 and EP2C8 devices) support four dedicated clock pins on each side (left and right) capable of driving a total of eight global clock networks, while the larger devices (EP2C20 devices and larger) support four clock pins on all four sides of the device. These clock pins can drive a total of 16 global clock networks.

Table 7-8 shows the number of global clocks available across the Cyclone II family members.

Device	Number of Global Clocks
EP2C5	8
EP2C8	8
EP2C20	16
EP2C35	16
EP2C50	16
EP2C70	16

Global Clock Network

Global clocks drive throughout the entire device, feeding all device quadrants. All resources within the device (IOEs, logic array blocks (LABs), dedicated multiplier blocks, and M4K memory blocks) can use the global clock networks as clock sources. These clock network resources can also be used for control signals, such as clock enables and synchronous or asynchronous clears fed by an external pin. Internal logic can also drive the global clock networks for internally generated global clocks and asynchronous clears, clock enables, or other control signals with high fan-out.

Table 7-9 shows the clock sources connectivity to the global clock networks.

Global Clock Network Clock Sources	Global Clock Networks															
	All Cyclone II Devices								EP2C20 through EP2C70 Devices Only							
	0	1	2	3	4	5	6	7	8	9	10	11	12	13	14	15
CLK0/LVDSCLK1p	✓		✓													
CLK1/LVDSCLK1n		✓	✓													
CLK2/LVDSCLK2p	✓			✓												
CLK3/LVDSCLK2n		✓		✓												
CLK4/LVDSCLK3p					✓		✓									
CLK5/LVDSCLK3n						✓	✓									

Table 7–9. Global Clock Network Connections (Part 2 of 3)

Global Clock Network Clock Sources	Global Clock Networks															
	All Cyclone II Devices							EP2C20 through EP2C70 Devices Only								
	0	1	2	3	4	5	6	7	8	9	10	11	12	13	14	15
CLK6/LVDSCLK4p					✓			✓								
CLK7/LVDSCLK4n						✓		✓								
CLK8/LVDSCLK5p									✓		✓					
CLK9/LVDSCLK5n										✓	✓					
CLK10/LVDSCLK6p									✓			✓				
CLK11/LVDSCLK6n										✓		✓				
CLK12/LVDSCLK7p													✓		✓	
CLK13/LVDSCLK7n														✓	✓	
CLK14/LVDSCLK8p													✓			✓
CLK15/LVDSCLK8n														✓		✓
PLL1_c0	✓	✓		✓												
PLL1_c1	✓		✓	✓												
PLL1_c2		✓	✓													
PLL2_c0					✓	✓		✓								
PLL2_c1					✓		✓	✓								
PLL2_c2						✓	✓									
PLL3_c0									✓	✓		✓				
PLL3_c1									✓		✓	✓				
PLL3_c2										✓	✓					
PLL4_c0													✓	✓		✓
PLL4_c1													✓		✓	✓
PLL4_c2														✓	✓	
DPCLK0 (1)	✓															
DPCLK1 (1)		✓														
DPCLK10 (1), (2) CDPCLK0 or CDPCLK7 (3)			✓													

Table 7–9. Global Clock Network Connections (Part 3 of 3)

Global Clock Network Clock Sources	Global Clock Networks															
	All Cyclone II Devices							EP2C20 through EP2C70 Devices Only								
	0	1	2	3	4	5	6	7	8	9	10	11	12	13	14	15
DPCLK2 (1), (2) CDPCLK1 or CDPCLK2 (3)				✓												
DPCLK7 (1)					✓											
DPCLK6 (1)						✓										
DPCLK8 (1), (2) CDPCLK5 or CDPCLK6 (3)							✓									
DPCLK4 (1), (2) CDPCLK4 or CDPCLK3 (3)								✓								
DPCLK8 (1)									✓							
DPCLK11 (1)										✓						
DPCLK9 (1)											✓					
DPCLK10 (1)												✓				
DPCLK5 (1)													✓			
DPCLK2 (1)														✓		
DPCLK4 (1)															✓	
DPCLK3 (1)																✓

Notes to Table 7–9:

- (1) See the *Cyclone II Architecture* chapter in Volume 1 of the *Cyclone II Device Handbook* for more information on DPCLK pins.
- (2) This pin only applies to EP2C5 and EP2C8 devices.
- (3) These pins only applies to EP2C20 devices and larger. Only one of the two CDPCLK pins can feed the clock control block. The other pin can be used as a regular I/O pin.

If the dedicated clock pins are not used to feed the global clock networks, they can be used as general-purpose input pins to feed the logic array using the MultiTrack interconnect. However, if they are used as general-purpose input pins, they do not have support for an I/O register and must use LE-based registers in place of an I/O register.

Clock Control Block

Every global clock network is driven by a clock control block residing either on the top, bottom, left, or right side of the Cyclone II device. The global clock network has been optimized for minimum clock skew and delay.

Table 7–10 lists the sources that can feed the clock control block, which in turn feeds the global clock networks.

Input	Description
Dedicated clock inputs	Dedicated clock input pins can drive clocks or global signals, such as asynchronous clears, presets, or clock enables onto a given global clock network.
Dual-purpose clock (DPCLK and CDPCLK) I/O inputs	DPCLK and CDPCLK I/O pins are bidirectional dual function pins that can be used for high fan-out control signals, such as protocol signals, TRDY and IRDY signals for PCI, or DQS for DDR, via the global clock network.
PLL outputs	The PLL counter outputs can drive the global clock network.
Internal logic	The global clock network can also be driven through the logic array routing to enable internal logic (LEs) to drive a high fan-out, low skew signal path.

In Cyclone II devices, the dedicated clock input pins, PLL counter outputs, dual-purpose clock I/O inputs, and internal logic can all feed the clock control block for each global clock network. The output from the clock control block in turn feeds the corresponding global clock network. The clock control blocks are arranged on the device periphery and there are a maximum of 16 clock control blocks available per Cyclone II device.

The control block has two functions:

- Dynamic global clock network clock source selection
- Global clock network power-down (dynamic enable and disable)

Figure 7–14 shows the clock control block.

Figure 7-14. Clock Control Block

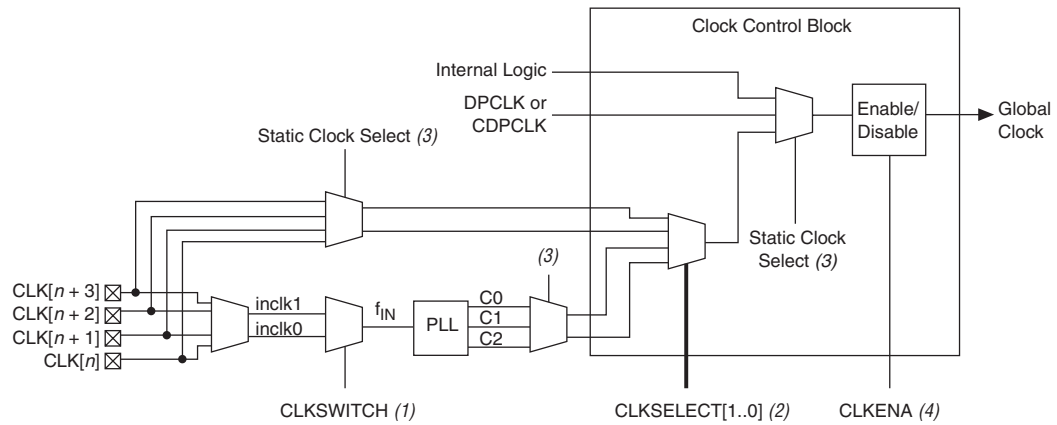
**Notes to Figure 7-14:**

- (1) The $CLKSWITCH$ signal can either be set through the configuration file or dynamically set when using the manual PLL switchover feature. The output of the multiplexer is the input reference clock (f_{IN}) for the PLL.
- (2) The $CLKSELECT[1..0]$ signals are fed by internal logic and can be used to dynamically select the clock source for the global clock network when the device is in user mode.
- (3) The static clock select signals are set in the configuration file and cannot be dynamically controlled when the device is in user mode.
- (4) Internal logic can be used to enable or disable the global clock network in user mode.

Each PLL generates three clock outputs through the $c[1..0]$ and $c2$ counters. Two of these clocks can drive the global clock network through the clock control block.

Global Clock Network Clock Source Generation

There are a total of 8 clock control blocks on the smaller Cyclone II devices (EP2C5 and EP2C8 devices) and a total of 16 clock control blocks on the larger Cyclone II devices (EP2C20 devices and larger). Figure 7-15 shows the Cyclone II clock inputs and the clock control blocks placement.

Figure 7–15. Cyclone II Clock Control Blocks Placement

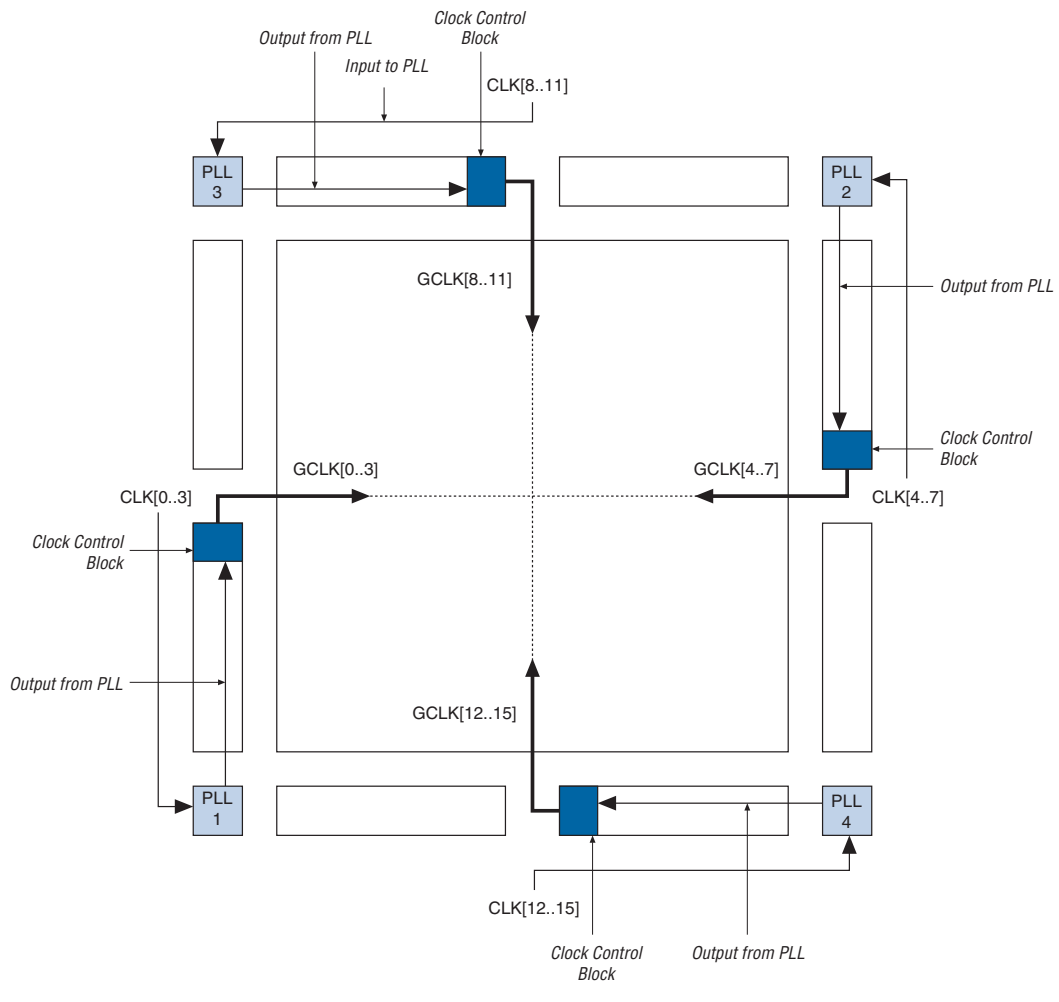

The inputs to the four clock control blocks on each side are chosen from among the following clock sources:

- Four clock input pins
- Three PLL counter outputs
- Two DPCLK pins and two CDPCLK pins from both the left and right sides and four DPCLK pins and two CDPCLK pins from both the top and bottom
- Four signals from internal logic

From the clock sources listed above, only two clock input pins, two PLL clock outputs, one DPCLK or CDPCLK pin, and one source from internal logic can drive into any given clock control blocks, as shown in Figure 7-14. Out of these six inputs to any clock control block, the two clock input pins and two PLL outputs can be dynamic selected to feed a global clock network. The clock control block supports static selection of the DPCLK or CDPCLK pin and the signal from internal logic.

Figure 7-16 shows the simplified version of the four clock control blocks on each side of the Cyclone II device periphery. The Cyclone II devices support up to 16 of these clock control blocks and this allows for up to a maximum of 16 global clocks in Cyclone II devices.

Figure 7-16. Clock Control Blocks on Each Side of the Cyclone II Device

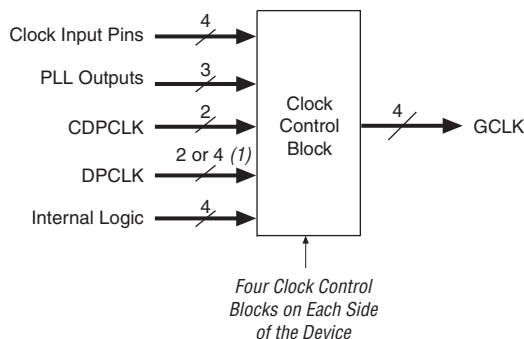

Note to Figure 7-16:

- (1) The left and right sides of the device have two DPCLK pins, and the top and bottom of the device have four DPCLK pins.

Global Clock Network Power Down

The Cyclone II global clock network can be disabled (powered down) by both static and dynamic approaches. When a clock network is powered down, all the logic fed by the clock network is in an off-state, thereby reducing the overall power consumption of the device.

The global clock networks that are not used are automatically powered down through configuration bit settings in the configuration file generated by the Quartus II software.

The dynamic clock enable or disable feature allows internal logic to synchronously control power up or down on the global clock networks in the Cyclone II device. This function is independent of the PLL and is applied directly on the clock network, as shown in Figure 7-14. The input

clock sources and the `clkena` signals for the global clock network multiplexers can be set through the Quartus II software using the `altclkctrl` megafunction.

clkena signals

In Cyclone II devices, the `clkena` signals are supported at the clock network level. Figure 7-17 shows how the `clkena` is implemented. This allows you to gate off the clock even when a PLL is not being used. Upon re-enabling the output clock, the PLL does not need a resynchronization or relock period because the clock is gated off at the clock network level. Also, the PLL can remain locked independent of the `clkena` signals since the loop-related counters are not affected.

Figure 7-17. `clkena` Implementation

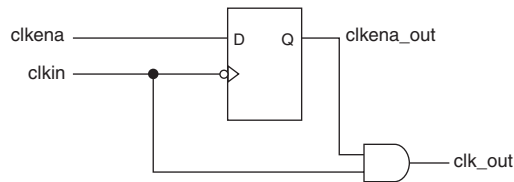
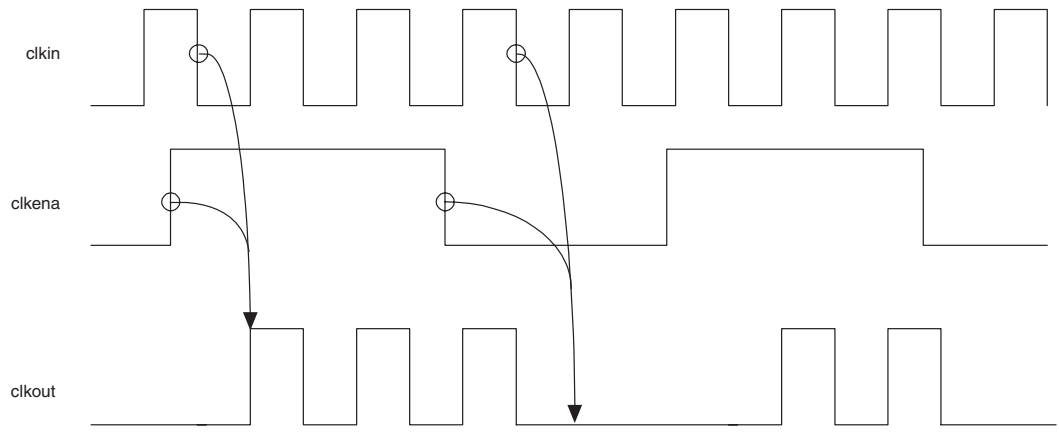

Figure 7-18 shows the waveform example for a clock output enable. `clkena` is synchronous to the falling edge of the clock (`clkina`).

This feature is useful for applications that require a low power or sleep mode. The exact amount of power saved when using this feature is pending device characterization.

Figure 7-18. clkena Implementation

The `clkena` signal can also disable clock outputs if the system is not tolerant to frequency overshoot during PLL resynchronization.

Altera recommends using the `clkena` signals when switching the clock source to the PLLs or the global clock network. The recommended sequence to be followed is:

1. Disable the primary output clock by de-asserting the `clkena` signal.
2. Switch to the secondary clock using the dynamic select signals of the clock control block.
3. Allow some clock cycles of the secondary clock to pass before re-asserting the `clkena` signal. The exact number of clock cycles you need to wait before enabling the secondary clock is design dependent. You can build custom logic to ensure glitch-free transition when switching between different clock sources.

Conclusion

Cyclone II device PLLs provide you with complete control of device clocks and system timing. These PLLs support clock multiplication/division, phase shift, and programmable duty cycle and programmable bandwidth for your cost-sensitive clock synthesis applications.

In addition, the clock networks in the Cyclone II device support dynamic selection of the clock source and also support a power-down mode where clock networks that are not being used can easily be turned off, reducing the overall power consumption of the device.

This section provides information on embedded memory blocks in Cyclone™ II devices and the supported external memory interfaces.

This section includes the following chapters:

- Chapter 8, Cyclone II Memory Blocks
- Chapter 9, External Memory Interfaces

Revision History

The table below shows the revision history for Chapters 8 and 9.

Chapter(s)	Date / Version	Changes Made
8	June 2004, v1.0	Added document to the Cyclone II Device Handbook.
9	November 2004, v1.1	<ul style="list-style-type: none"> ● Moved the “External Memory Interface Standards” section to follow the “Introduction” section. ● Updated the “Data & Data Strobe Pins” section. ● Updated Figures 9–11, 9–12, 9–15, 9–16, and 9–17.
	June 2004, v1.0	Added document to the Cyclone II Device Handbook.

Introduction

Cyclone™ II devices feature embedded memory structures to address the on-chip memory needs of FPGA designs. The embedded memory structure consists of columns of M4K memory blocks that can be configured to provide various memory functions such as RAM, first-in first-out (FIFO) buffers, and ROM. M4K memory blocks provide over 1 Mbit of RAM at up to 250-MHz operation (see [Table 8–2 on page 8–2](#) for total RAM bits per density).

Overview

The M4K blocks support the following features:

- Over 1 Mbit of RAM available without reducing available logic
- 4,096 memory bits per block (4,608 bits per block including parity)
- Variable port configurations
- True dual-port (one read and one write, two reads, or two writes) operation
- Byte enables for data input masking during writes
- Initialization file to pre-load content of memory in RAM and ROM modes
- Up to 250-MHz operation

[Table 8–1](#) summarizes the features supported by the M4K memory.

<i>Table 8–1. Summary of M4K Memory Features (Part 1 of 2)</i>	
Feature	M4K Blocks
Maximum performance <i>(1)</i>	250 MHz
Total RAM bits (including parity bits)	4,608
Configurations	4K × 1 2K × 2 1K × 4 512 × 8 512 × 9 256 × 16 256 × 18 128 × 32 128 × 36
Parity bits	✓
Byte enable	✓

Feature	M4K Blocks
Packed mode	✓
Address clock enable	✓
Single-port mode	✓
Simple dual-port mode	✓
True dual-port mode	✓
Embedded shift register mode (2)	✓
ROM mode	✓
FIFO buffer (2)	✓
Simple dual-port mixed width support	✓
True dual-port mixed width support	✓
Memory Initialization File (.mif)	✓
Mixed-clock mode	✓
Power-up condition	Outputs cleared
Register clears	Output registers only
Same-port read-during-write	New data available at positive clock edge
Mixed-port read-during-write	Old data available at positive clock edge

Notes to Table 8–1:

- (1) Maximum performance information is preliminary until device characterization.
- (2) FIFO buffers and embedded shift registers require external logic elements (LEs) for implementing control logic.

Table 8–2 shows the capacity and distribution of the M4K memory blocks in each Cyclone II device family member.

Device	M4K Blocks	Total RAM Bits
EP2C5	26	119,808
EP2C8	36	165,888
EP2C20	52	239,616
EP2C35	105	483,840

Table 8–2. Number of M4K Blocks in Cyclone II Devices (Part 2 of 2)

Device	M4K Blocks	Total RAM Bits
EP2C50	129	594,432
EP2C70	250	1,152,000

Control Signals

Figure 8–1 shows how the register clocks, clears, and control signals are implemented in the Cyclone II memory block.

The clock enable control signal controls the clock entering the entire memory block, not just the input and output registers. The signal disables the clock so that the memory block does not see any clock edges and will not perform any operations.

Cyclone II devices do not support asynchronous clear signals to input registers. Only output registers support asynchronous clears. There are three ways to reset the registers in the M4K blocks: power up the device, use the `aclr` signal for output register only, or assert the device-wide reset signal using the `DEV_CLRn` option.

Figure 8–1. M4K Control Signal Selection

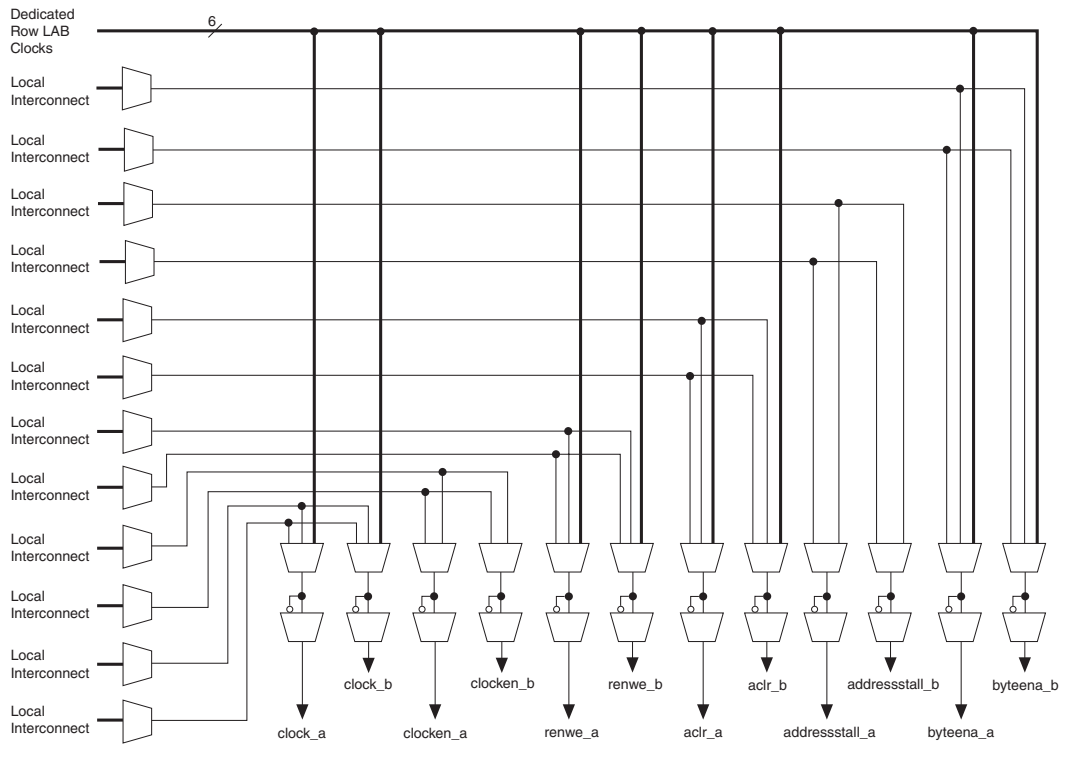

Parity Bit Support

Error detection using parity check is possible using the parity bit, with additional logic implemented in LEs to ensure data integrity. Parity-size data words can also be used for other purposes such as storing user-specified control bits.



See the *Using Parity to Detect Memory Errors White Paper* for more information.

Byte Enable Support

All M4K memory blocks support byte enables that mask the input data so that only specific bytes of data are written. The unwritten bytes retain the previous written value. The write enable (*wren*) signals, along with the byte enable (*byteena*) signals, control the RAM block's write operations. The default value for the byte enable signals is high (enabled), in which

case writing is controlled only by the write enable signals. There is no clear port to the byte enable registers. M4K blocks support byte enables when the write port has a data width of 1, 2, 4, 8, 9, 16, 18, 32, or 36 bits. When using data widths of 1, 2, 4, 8, and 9 bits, the byte enable behaves as a redundant write enable because the data width is less than or equal to a single byte. Table 8–3 summarizes the byte selection.

Table 8–3. Byte Enable for Cyclone II M4K Blocks Note (1)

byteena[3..0]	Affected Bytes								
	datain ×1	datain ×2	datain ×4	datain ×8	datain ×9	datain ×16	datain ×18	datain ×32	datain ×36
[0] = 1	[0]	[1..0]	[3..0]	[7..0]	[8..0]	[7..0]	[8..0]	[7..0]	[8..0]
[1] = 1	-	-	-	-	-	[15..8]	[17..9]	[15..8]	[17..9]
[2] = 1	(2)	(2)	(2)	(2)	(2)	-	-	[23..16]	[26..18]
[3] = 1	-	-	-	-	-	-	-	[31..24]	[35..27]

Notes to Table 8–3:

- (1) Any combination of byte enables is possible.
- (2) In true dual-port mode, set byteena [0] to 1 and byteena [2] to 1. For single port and simple dual-port mode, only set byteena [0] to 1.

Figure 8–2 shows how the wren and byteena signals control the operations of the RAM.

When a byte enable bit is de-asserted during a write cycle, the corresponding data byte output appears as a “don’t care” or unknown value. When a byte enable bit is asserted during a write cycle, the corresponding data byte output will be the newly written data.

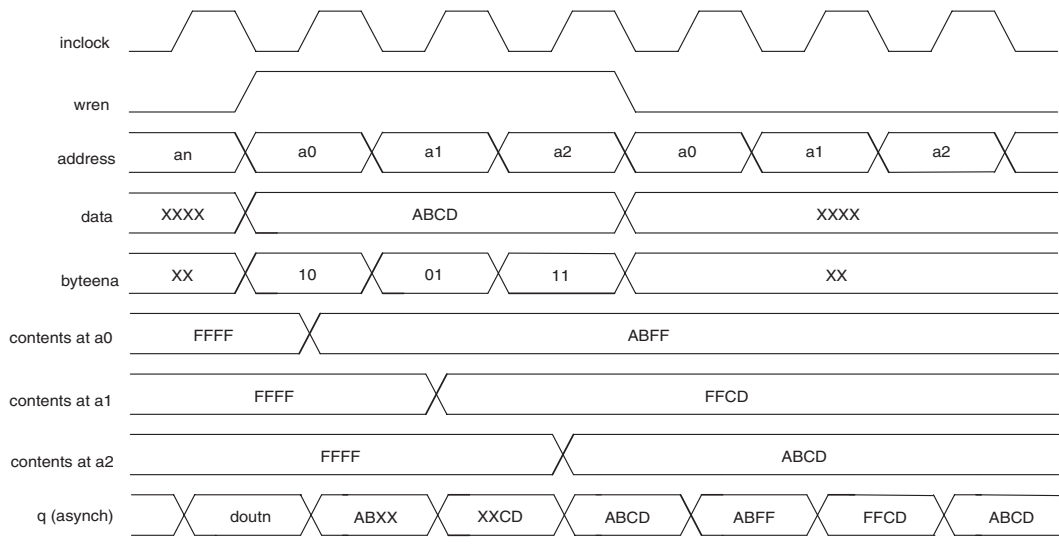
Figure 8–2. Cyclone II Byte Enable Functional Waveform

Packed Mode Support

Cyclone II M4K memory blocks support packed mode. You can implement two single-port memory blocks in a single block under the following conditions:

- Each of the two independent block sizes is less than or equal to half of the M4K block size.
- Each of the single-port memory blocks is configured in single-clock mode.



See “[Single-Port Mode](#)” on page 8–9 and “[Single-Clock Mode](#)” on page 8–22 for more information.

Address Clock Enable

Cyclone II M4K memory blocks support address clock enables, which holds the previous address value until needed. When the memory blocks are configured in dual-port mode, each port has its own independent address clock enable.

[Figure 8–3](#) shows an address clock enable block diagram. The address register output is fed back to its input via a multiplexer. The multiplexer output is selected by the address clock enable (`addressstall`) signal.

Address latching is enabled when the `addressstall` signal goes high (active high). The output of the address register is then continuously fed into the input of the register until the `addressstall` signal goes low.

Figure 8–3. Cyclone II Address Clock Enable Block Diagram

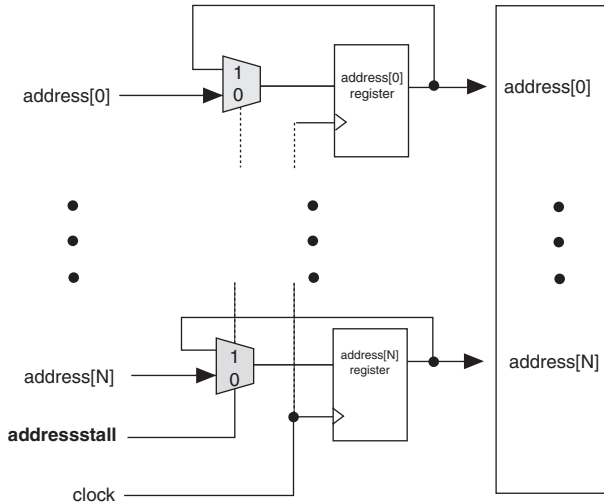

The address clock enable is typically used for cache memory applications to improve efficiency during a cache-miss. The default value for the address clock enable signals is low (disabled). [Figures 8–4](#) and [8–5](#) show the address clock enable waveforms during the read and write cycles, respectively.

Figure 8–4. Cyclone II Address Clock Enable During Read Cycle Waveform

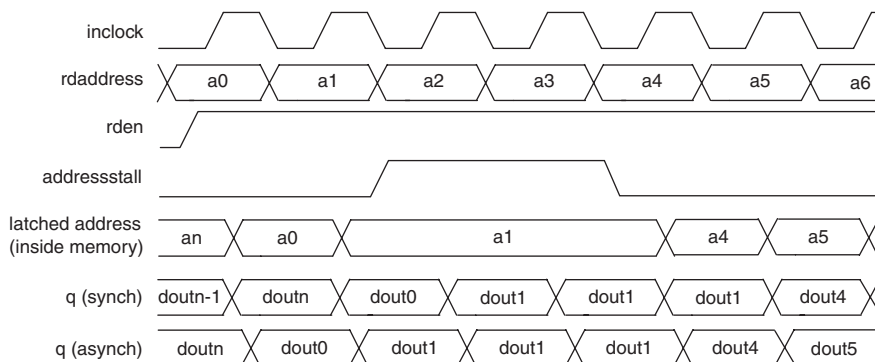
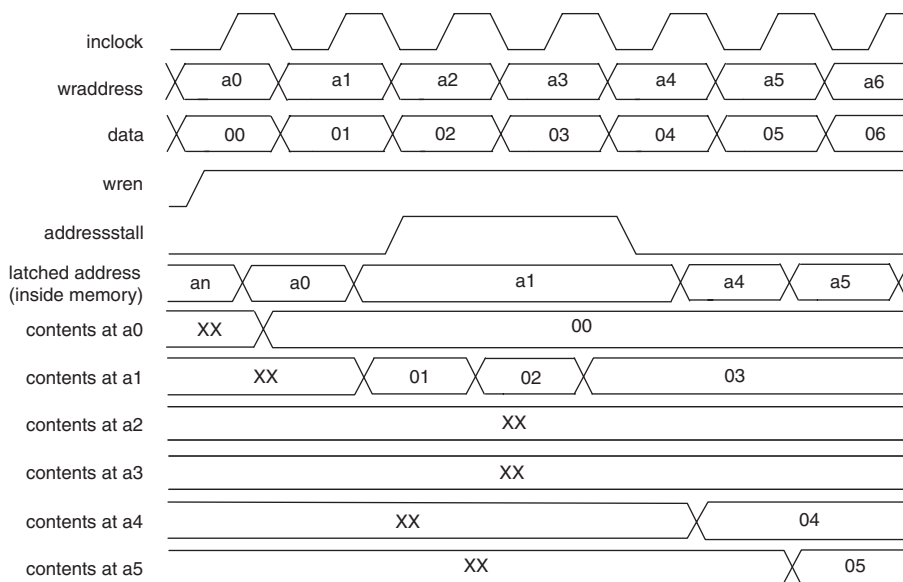



Figure 8–5. Cyclone II Address Clock Enable During Write Cycle Waveform



Memory Modes

Cyclone II M4K memory blocks include input registers that synchronize writes and output registers to pipeline data, thereby improving system performance. All M4K memory blocks are fully synchronous, meaning that you must send all inputs through a register, but you can either send outputs through a register (pipelined) or bypass the register (flow-through).

 M4K memory blocks do not support asynchronous memory (unregistered inputs).

The M4K memory blocks support the following modes:

- Single-port
- Simple dual-port
- True dual-port (bidirectional dual-port)
- Shift register
- ROM
- FIFO buffers

Single-Port Mode

Single-port mode supports non-simultaneous read and write operations. [Figure 8–6](#) shows the single-port memory configuration for Cyclone II memory blocks.

Figure 8–6. Single-Port Mode *Note (1)*

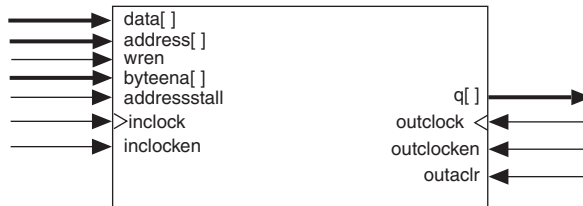

Note to Figure 8–6:

- (1) Two single-port memory blocks can be implemented in a single M4K block in packed mode.

In single-port mode, the outputs are in read-during-write mode, which means that during the write operation, data written to the RAM flows through to the RAM outputs. When the output registers are bypassed, the new data is available on the rising edge of the same clock cycle on which it was written.



See [“Read-During- Write Operation at the Same Address”](#) on page 8–26 for more information about read-during-write mode.

The port width configurations for M4K blocks in single-port mode are as follows:

- 4K × 1
- 2K × 2
- 1K × 4
- 512 × 8
- 512 × 9
- 256 × 16
- 256 × 18
- 128 × 32
- 128 × 36

[Figure 8–7](#) shows timing waveforms for read and write operations in single-port mode.

Figure 8–7. Cyclone II Single-Port Timing Waveforms

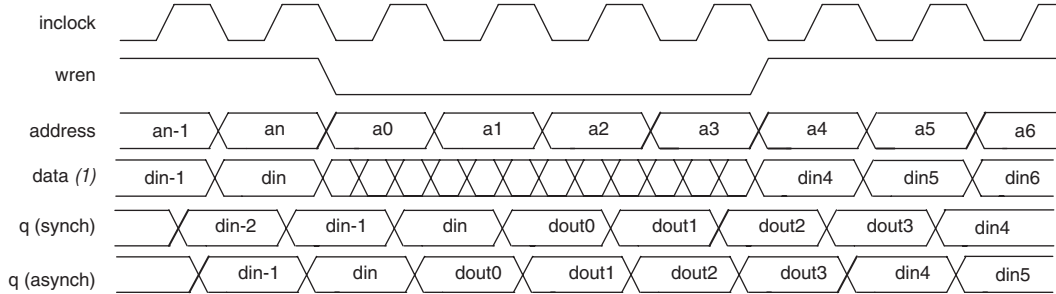

Note to Figure 8–7:

- (1) The crosses in the data waveform during read mean “don’t care.”

Simple Dual-Port Mode

Simple dual-port mode supports simultaneous read and write operation. Figure 8–8 shows the simple dual-port memory configuration.

Figure 8–8. Cyclone II Simple Dual-Port Mode Note (1)

Simple Dual-Port Memory

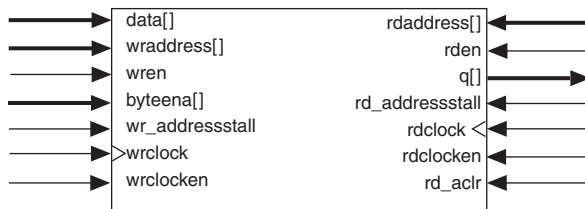

Note to Figure 8–8:

- (1) Simple dual-port RAM supports input and output clock mode in addition to the read and write clock mode shown.

Cyclone II memory blocks support mixed-width configurations, allowing different read and write port widths. [Tables 8–4 and 8–5](#) show the mixed-width configurations.

Table 8–4. Cyclone II Memory Block Mixed-Width Configurations (Simple Dual-Port Mode)

Read Port	Write Port								
	4K × 1	2K × 2	1K × 4	512 × 8	256 × 16	128 × 32	512 × 9	256 × 18	128 × 36
4K × 1	✓	✓	✓	✓	✓	✓			
2K × 2	✓	✓	✓	✓	✓	✓			
1K × 4	✓	✓	✓	✓	✓	✓			
512 × 8	✓	✓	✓	✓	✓	✓			
256 × 16	✓	✓	✓	✓	✓	✓			
128 × 32	✓	✓	✓	✓	✓	✓			
512 × 9							✓	✓	✓
256 × 18							✓	✓	✓
128 × 36							✓	✓	✓

In simple dual-port mode, the memory blocks have one write enable and one read enable signal. They do not support a clear port on the write enable and read enable registers. When the read enable is deactivated, the current data is retained at the output ports. If the read enable is activated during a write operation with the same address location selected, the simple dual-port RAM output is the old data stored at the memory address. See [“Read-During- Write Operation at the Same Address”](#) on [page 8–26](#) for more information. [Figure 8–9](#) shows timing waveforms for read and write operations in simple dual-port mode.

Figure 8–9. Cyclone II Simple Dual-Port Timing Waveforms

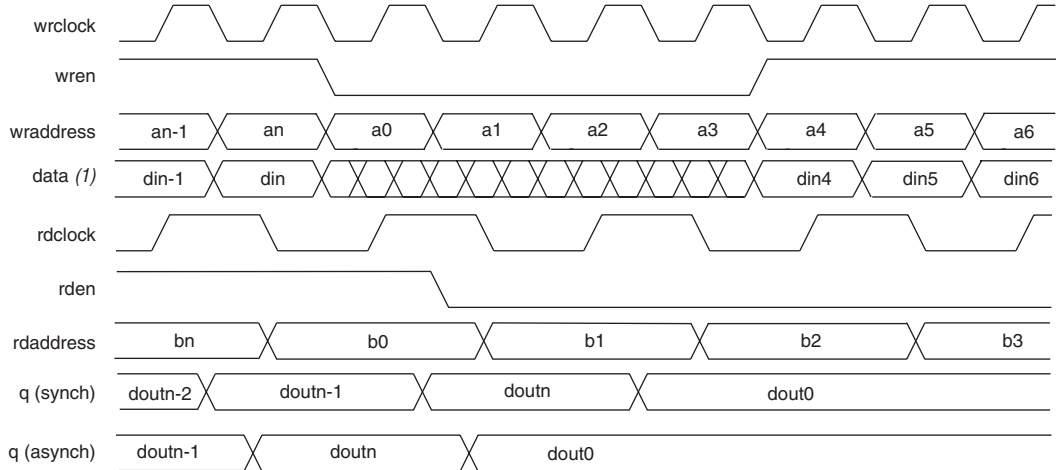

Note to Figure 8–9:

- (1) The crosses in the data waveform during read mean “don’t care.”

True Dual-Port Mode

True dual-port mode supports any combination of two-port operations: two reads, two writes, or one read and one write at two different clock frequencies. Figure 8–10 shows Cyclone II true dual-port memory configuration.

Figure 8–10. Cyclone II True Dual-Port Mode *Note (1)*

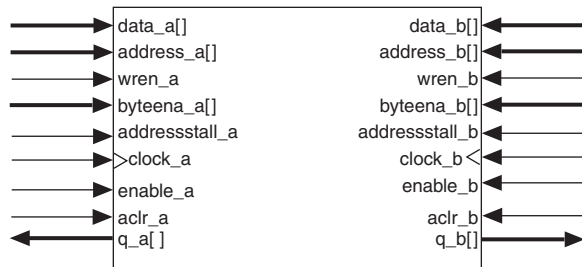

Note to Figure 8–10:

- (1) True dual-port memory supports input and output clock mode in addition to the independent clock mode shown.

The widest bit configuration of the M4K blocks in true dual-port mode is 256×16 -bit (18-bit with parity).

The 128×32 -bit (36-bit with parity) configuration of the M4K block is unavailable because the number of output drivers is equivalent to the maximum bit width. The maximum width of the true dual-port RAM equals half of the total number of output drivers because true dual-port RAM has outputs on two ports. Table 8-5 lists the possible M4K block mixed-port width configurations.

Table 8-5. Cyclone II Memory Block Mixed-Port Width Configurations (True Dual-Port)

Read Port	Write Port						
	$4K \times 1$	$2K \times 2$	$1K \times 4$	512×8	256×16	512×9	256×18
$4K \times 1$	✓	✓	✓	✓	✓		
$2K \times 2$	✓	✓	✓	✓	✓		
$1K \times 4$	✓	✓	✓	✓	✓		
512×8	✓	✓	✓	✓	✓		
256×16	✓	✓	✓	✓	✓		
512×9						✓	✓
256×18						✓	✓

In true dual-port configuration, the RAM outputs are in read-during-write mode. This means that during a write operation, data being written to the A or B port of the RAM flows through to the A or B outputs, respectively. When the output registers are bypassed, the new data is available on the rising edge of the same clock cycle on which it was written. See [“Read-During-Write Operation at the Same Address”](#) on page 8-26 for waveforms and information on mixed-port read-during-write mode.

Potential write contentions must be resolved external to the RAM because writing to the same address location at both ports results in unknown data storage at that location. Since data is written into the memory at the falling edge of the write clock, the rising edge of the write clock for port A should occur following half of the maximum write cycle time interval after the falling edge of the write clock for port B. If this timing is not met, the data stored in that particular address will be invalid.



See the *Cyclone II Device Family Data Sheet* in Volume 1 of the *Cyclone II Device Handbook* for the maximum synchronous write cycle time.

Figure 8–11 shows true dual-port timing waveforms for the write operation at port A and the read operation at port B.

Figure 8–11. Cyclone II True Dual-Port Timing Waveforms

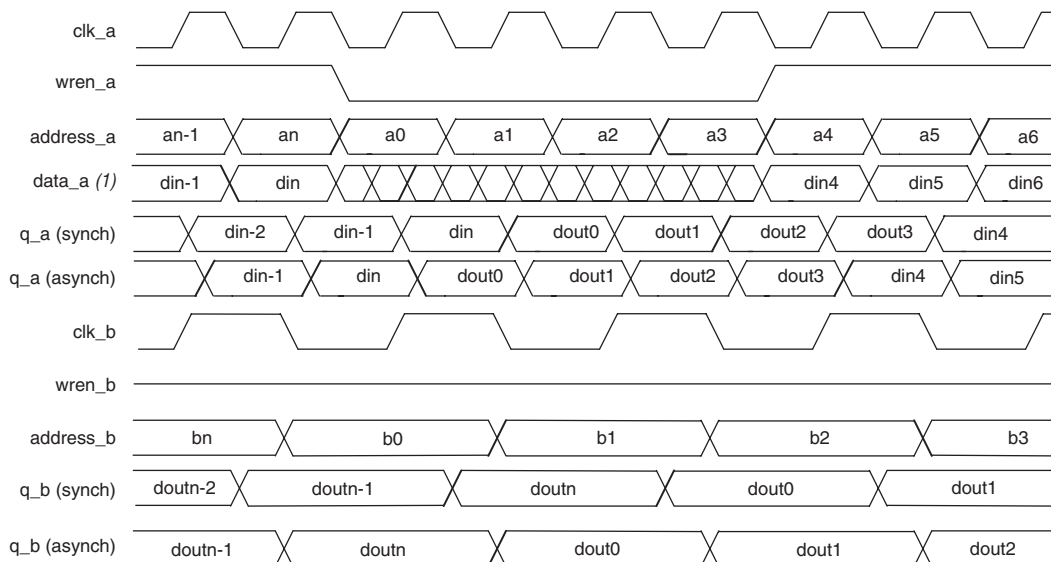

Note to Figure 8–11:

(1) The crosses in the data_a waveform during write indicate “don’t care.”

Shift Register Mode

Cyclone II memory blocks can implement shift registers for digital signal processing (DSP) applications, such as finite impulse response (FIR) filters, pseudo-random number generators, multi-channel filtering, and auto-correlation and cross-correlation functions. These and other DSP applications require local data storage, traditionally implemented with standard flip-flops that quickly exhaust many logic cells for large shift registers. A more efficient alternative is to use embedded memory as a shift register block, which saves logic cell and routing resources.

The size of a ($w \times m \times n$) shift register is determined by the input data width (w), the length of the taps (m), and the number of taps (n), and must be less than or equal to the maximum number of memory bits, which is 4,608 bits. In addition, the size of ($w \times n$) must be less than or equal to the maximum width of the block, which is 36 bits. If a larger shift register is required, the memory blocks can be cascaded.

Data is written into each address location at the falling edge of the clock and read from the address at the rising edge of the clock. The shift register mode logic automatically controls the positive and negative edge clocking to shift the data in one clock cycle. Figure 8–12 shows the Cyclone II memory block in the shift register mode.

Figure 8–12. Cyclone II Shift Register Mode Configuration

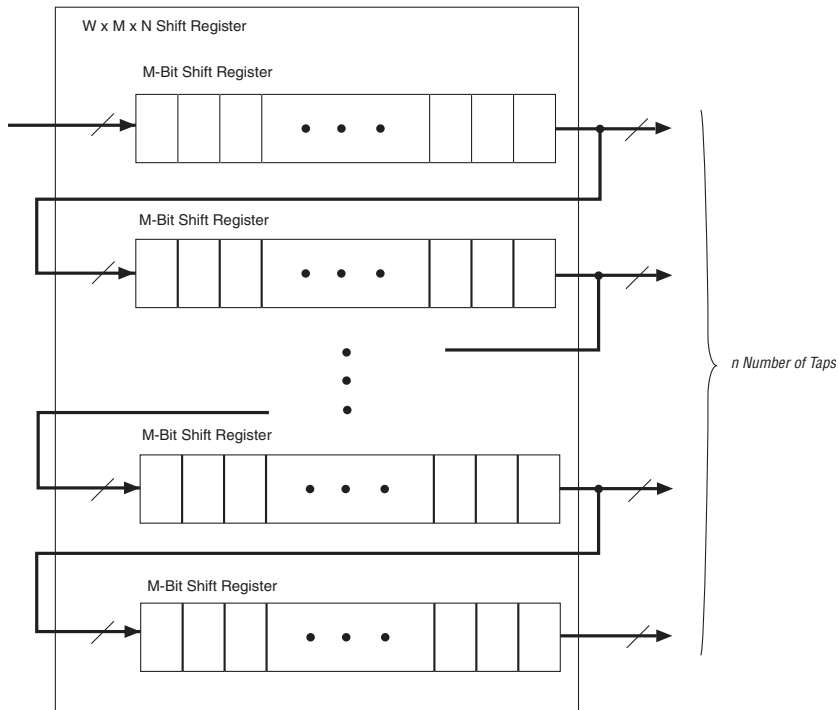

ROM Mode

Cyclone II memory blocks support ROM mode. A MIF initializes the ROM contents of these blocks. The address lines of the ROM are registered. The outputs can be registered or unregistered. The ROM read operation is identical to the read operation in the single-port RAM configuration.

FIFO Buffer Mode

A single clock or dual clock FIFO buffer may be implemented in the memory blocks. Dual clock FIFO buffers are useful when transferring data from one clock domain to another clock domain. All FIFO memory configurations have synchronous inputs. However, the FIFO buffer outputs are always combinational (i.e., not registered). Simultaneous read and write from an empty FIFO buffer is not supported.



See the *Single- & Dual-Clock FIFO Megafunctions User Guide* for more information on FIFO buffers.

Clock Modes

Depending on which memory mode is selected, the following clock modes are available:

- Independent
- Input/output
- Read/write
- Single-clock

Table 8–6 shows these clock modes supported by all memory blocks when configured in each respective memory modes.

Clocking Modes	True Dual-Port Mode	Simple Dual-Port Mode	Single-Port Mode
Independent	✓		
Input/output	✓	✓	✓
Read/write		✓	
Single clock	✓	✓	✓

Independent Clock Mode

Cyclone II memory blocks can implement independent clock mode for true dual-port memory. In this mode, a separate clock is available for each port (A and B). Clock A controls all registers on the port A side, while clock B controls all registers on the port B side. Each port also supports independent clock enables for port A and B registers. However, ports do not support asynchronous clear signals for the registers.

Figure 8–13 shows a memory block in independent clock mode.

Figure 8–13. Cyclone II Memory Block in Independent Clock Mode

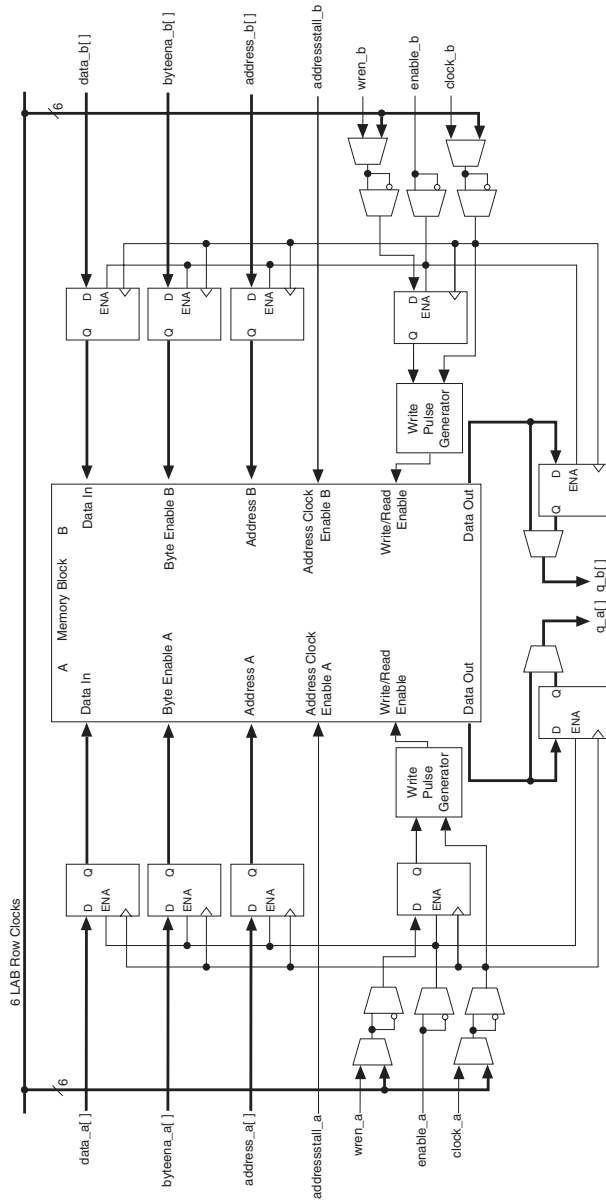

Input/Output Clock Mode

Cyclone II memory blocks can implement the input/output clock mode for true and simple dual-port memory. On each of the two ports, A and B, one clock controls all registers for the data, write enable, and address inputs into the memory block. The other clock controls the blocks' data output registers. Each memory block port also supports independent clock enables for input and output registers. Asynchronous clear signals for the registers are not supported.

Figures 8–14 through 8–16 show the memory block in input/output clock mode for true dual-port, simple dual-port, and single-port modes, respectively.

Figure 8–14. Cyclone II Input/Output Clock Mode in True Dual-Port Mode

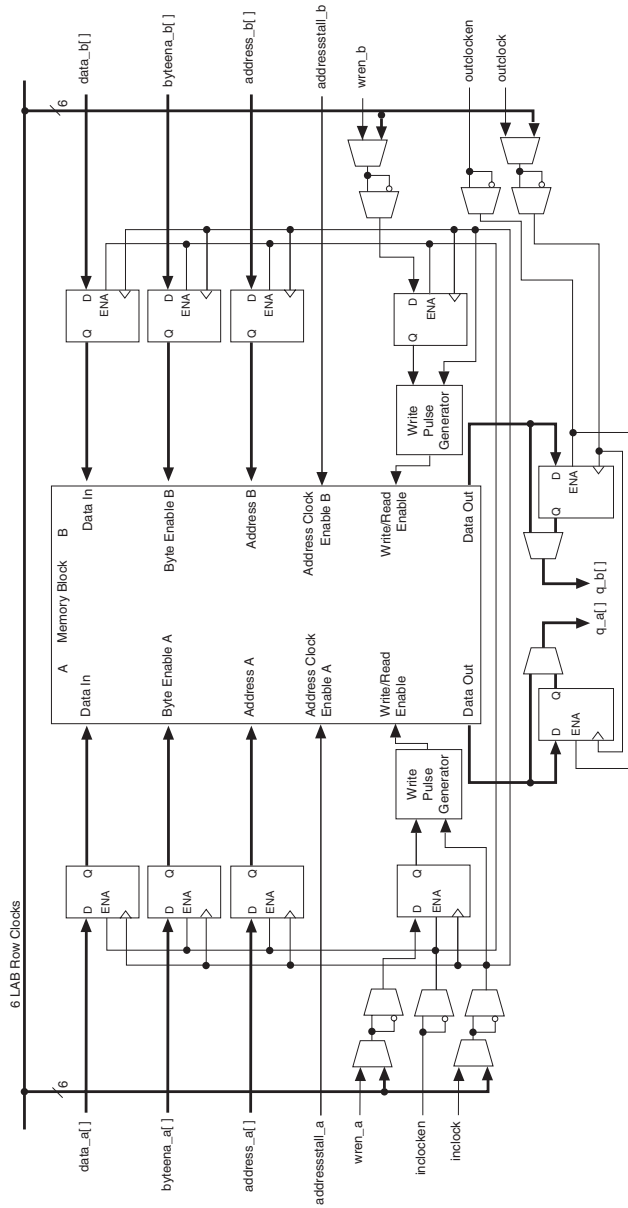
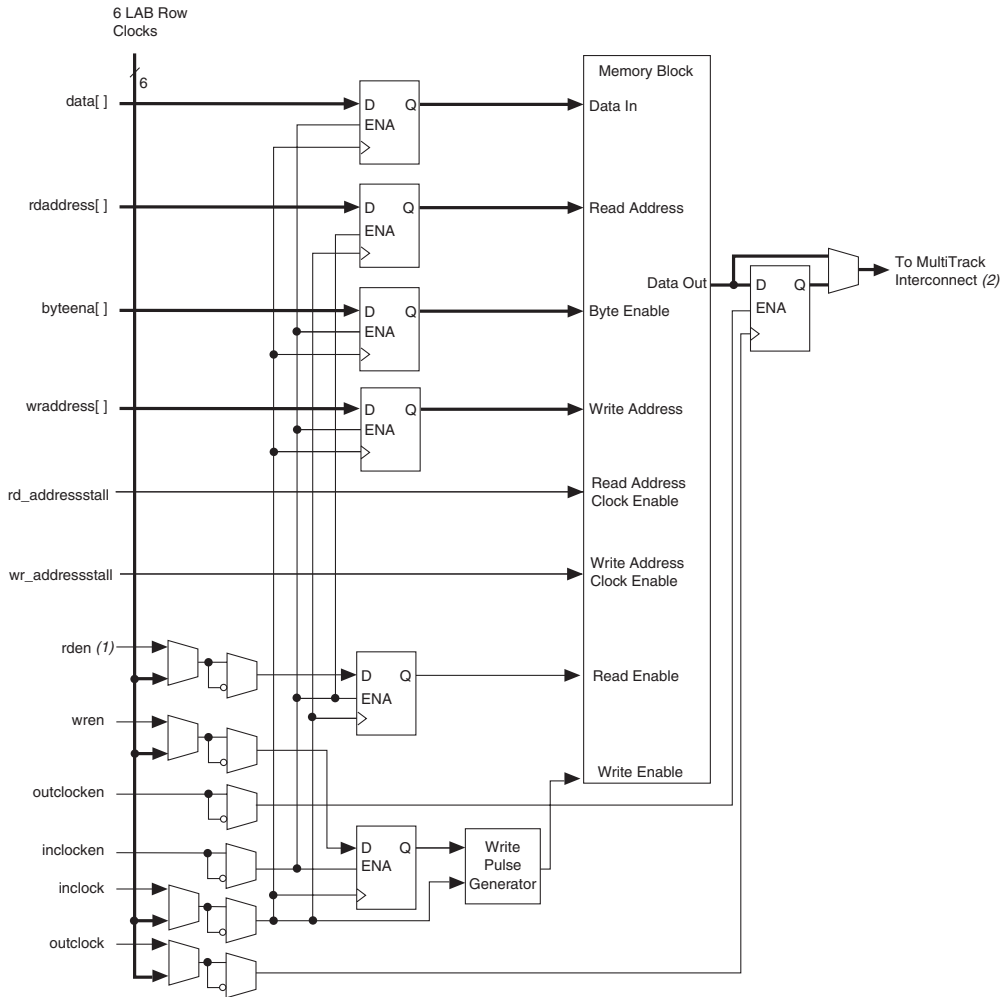
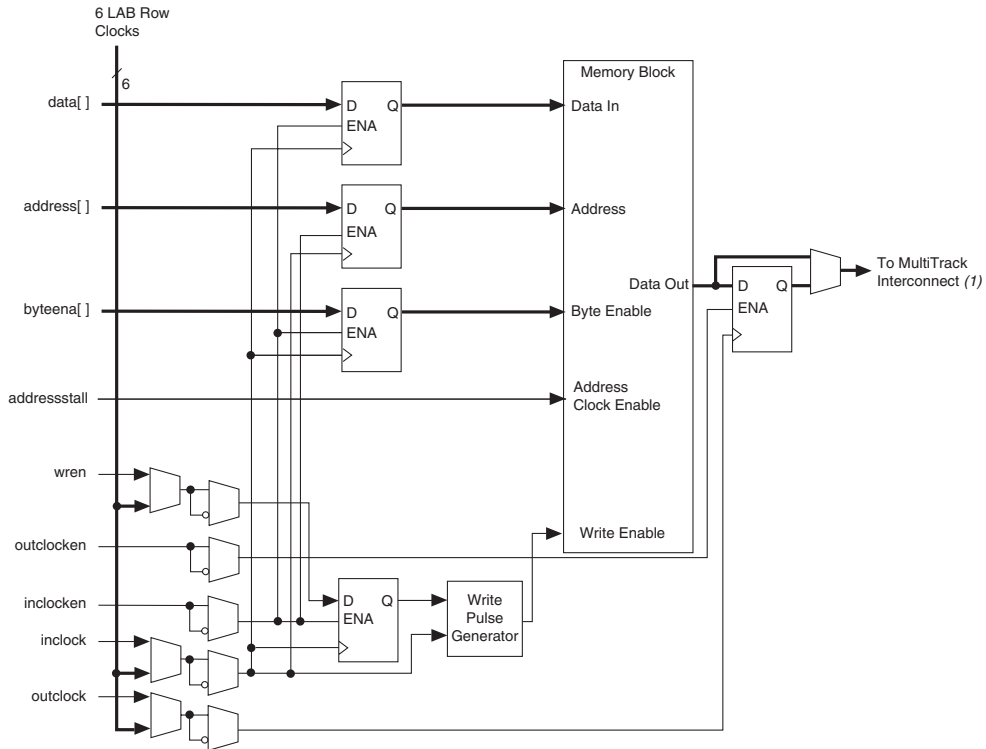

Figure 8–15. Cyclone II Input/Output Clock Mode in Simple Dual-Port Mode



Note to Figure 8–15:

- (1) See the *Cyclone II Device Family Data Sheet* in Volume 1 of the *Cyclone II Device Handbook* for more information on the MultiTrack™ interconnect.

Figure 8–16. Cyclone II Input/Output Clock Mode in Single-Port Mode**Note to Figure 8–16:**

- (1) See the *Cyclone II Device Family Data Sheet* in Volume 1 of the *Cyclone II Device Handbook* for more information on the MultiTrack interconnect.

Read/Write Clock Mode

Cyclone II memory blocks can implement read/write clock mode for simple dual-port memory. The write clock controls the blocks' data inputs, write address, and write enable signals. The read clock controls the data output, read address, and read enable signals. The memory blocks support independent clock enables for each clock for the read- and write-side registers. This mode does not support asynchronous clear signals for the registers. Figure 8–17 shows a memory block in read/write clock mode.

Figure 8–17. Cyclone II Read/Write Clock Mode

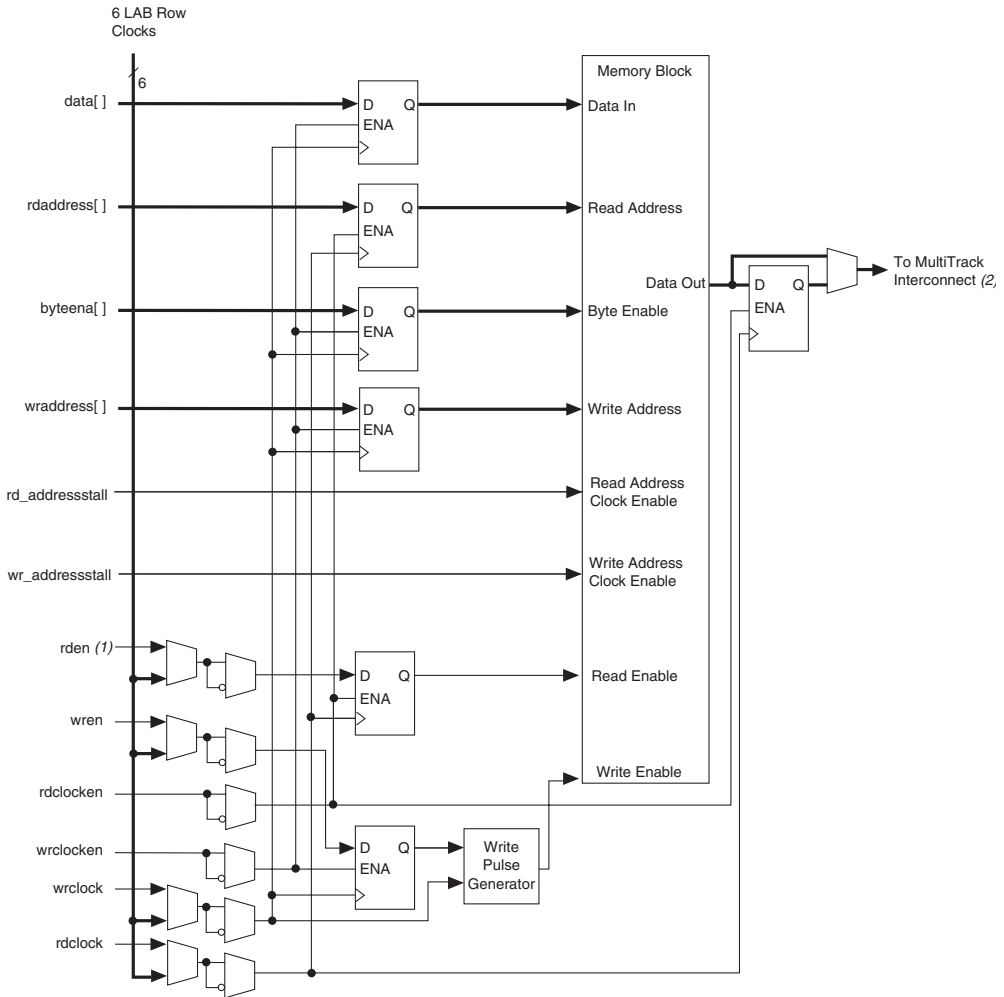

Note to Figure 8–17:

- (1) See the *Cyclone II Device Family Data Sheet* in Volume 1 of the *Cyclone II Device Handbook* for more information on the MultiTrack interconnect.

Single-Clock Mode

Cyclone II memory blocks support single-clock mode for true dual-port, simple dual-port, and single-port memory. In this mode, a single clock, together with a clock enable, controls all registers of the memory block.

This mode does not support asynchronous clear signals for the registers. Figures 8–18 through 8–20 show the memory block in single-clock mode for true dual-port, simple dual-port, and single-port modes, respectively.

Figure 8–18. Cyclone II Single-Clock Mode in True Dual-Port Mode

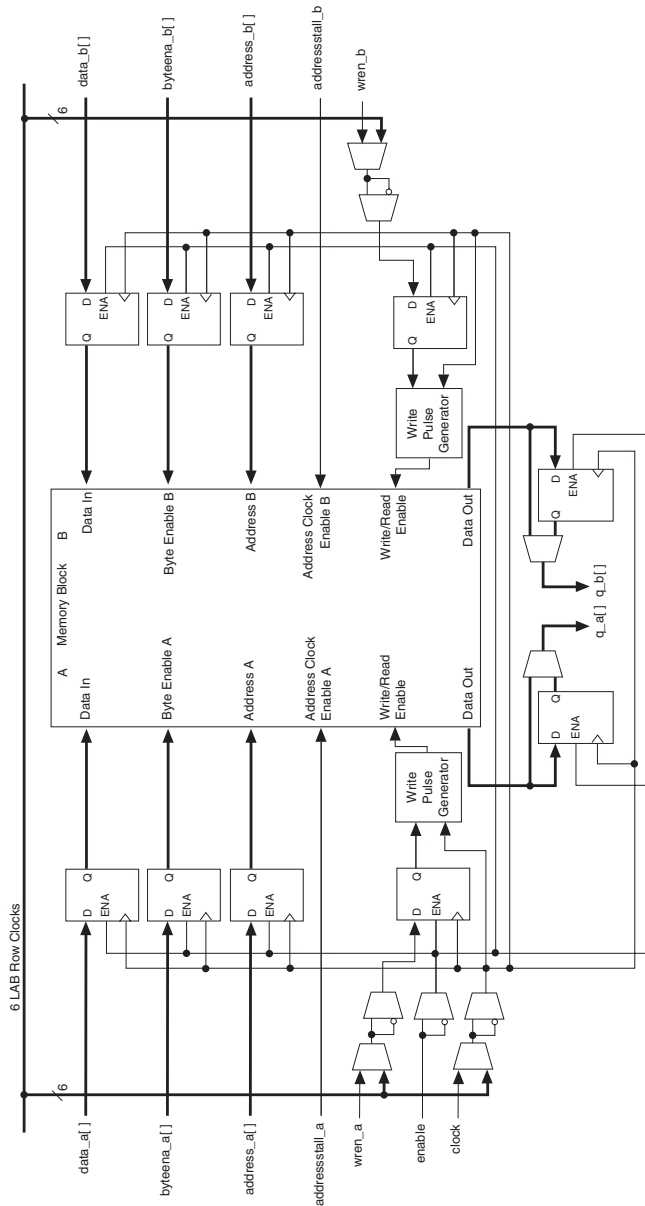
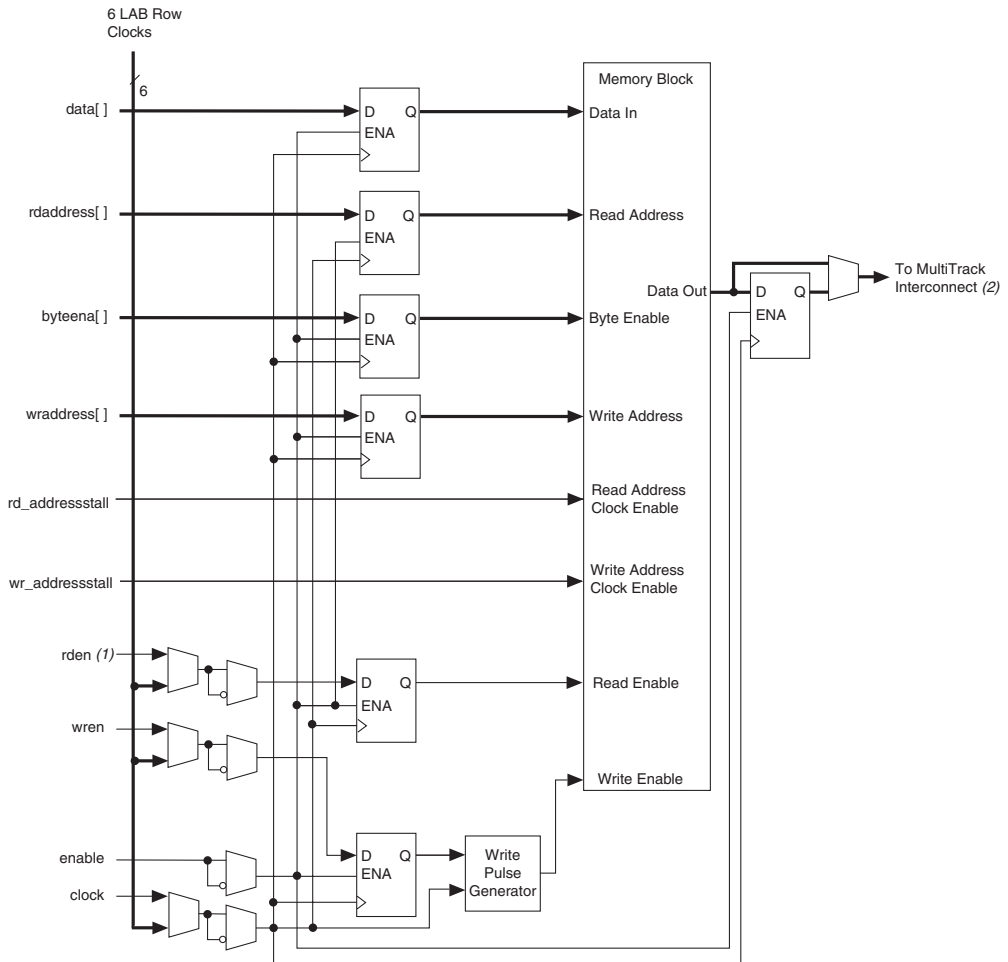
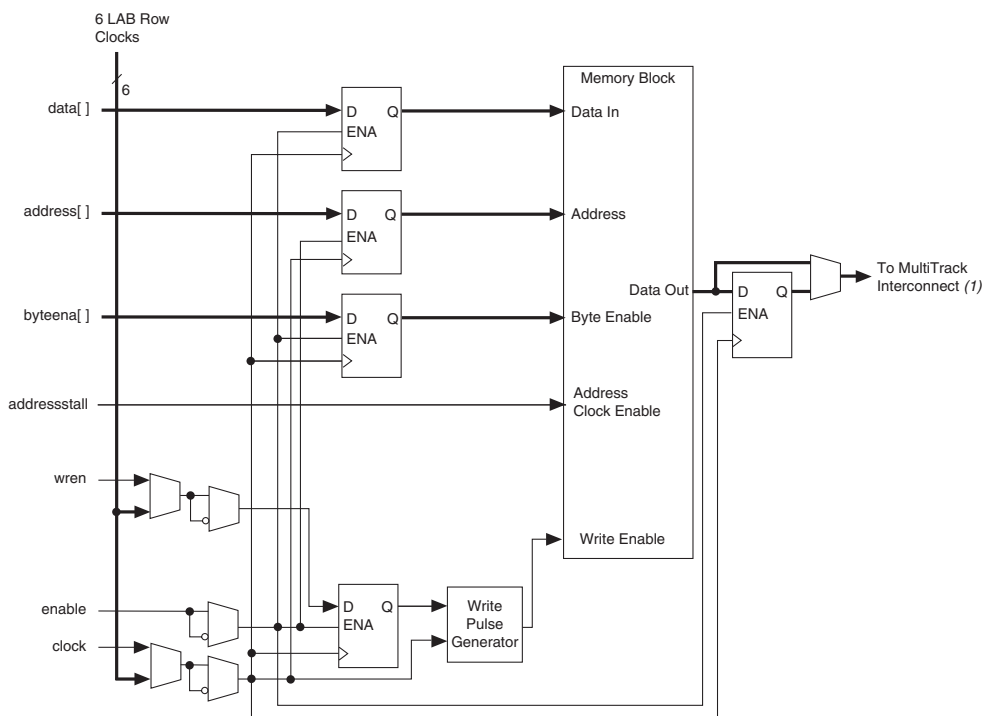

Figure 8–19. Cyclone II Single-Clock Mode in Simple Dual-Port Mode



Note to Figure 8–19:

- (1) See the *Cyclone II Device Family Data Sheet* in Volume 1 of the *Cyclone II Device Handbook* for more information on the MultiTrack interconnect.

Figure 8–20. Cyclone II Single-Clock Mode in Single-Port Mode**Note to Figure 8–20:**

- (1) See the *Cyclone II Device Family Data Sheet* in Volume 1 of the *Cyclone II Device Handbook* for more information on the MultiTrack interconnect.

Power-Up Conditions & Memory Initialization

The Cyclone II memory block outputs always power-up to zero, regardless of whether the output registers are used or bypassed. Even if an MIF pre-loads the contents of the memory block, the outputs will still power up cleared. For example, if address 0 is pre-initialized to FF, M4K blocks power up with the output at 00. A subsequent read after power up from address 0 will output the pre-initialized value of FF.

Read-During-Write Operation at the Same Address

The “*Same-Port Read-During-Write Mode*” and “*Mixed-Port Read-During-Write Mode*” sections describe the functionality of the various RAM configurations when reading from an address during a write operation at that same address. There are two read-during-write data flows: same-port and mixed-port. Figure 8–21 shows the difference between these flows.

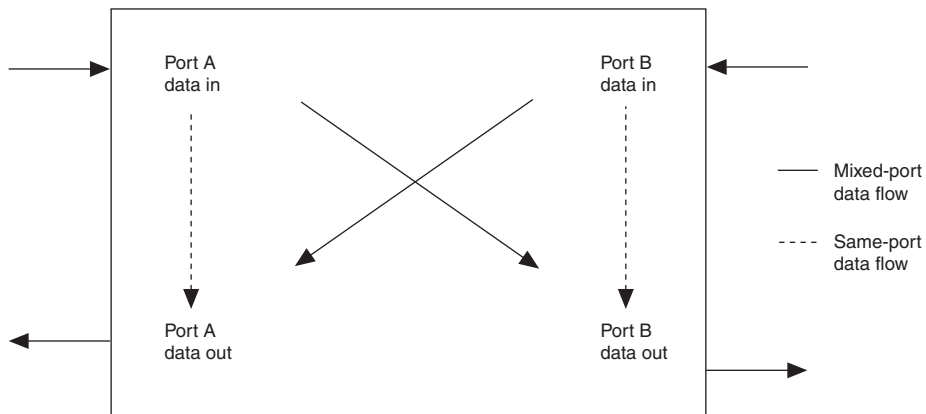
Figure 8–21. Cyclone II Read-During-Write Data Flow

Same-Port Read-During-Write Mode

For read-during-write operation of a single-port RAM or the same port of a true dual-port RAM, the new data is available on the rising edge of the same clock cycle on which it was written. Figure 8–22 shows a sample functional waveform. When using byte enables in true dual-port RAM mode, the outputs for the masked bytes on the same port are unknown (see Figure 8–2 on page 8–6). The non-masked bytes are read out as shown in Figure 8–22.

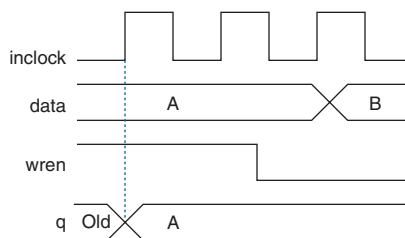
Figure 8–22. Cyclone II Same-Port Read-During-Write Functionality *Note (1)*

Note to Figure 8–22:

(1) Outputs are not registered.

Mixed-Port Read-During-Write Mode

This mode is used when a RAM in simple or true dual-port mode has one port reading and the other port writing to the same address location with the same clock. The memory block outputs the old data at the specified address when there is a simultaneous read during write to the same port. [Figure 8–23](#) shows a sample functional waveform where both ports have the same address. This figure assumes that the outputs are not registered.

Figure 8–23. Cyclone II Mixed-Port Read-During-Write *Note (1)*

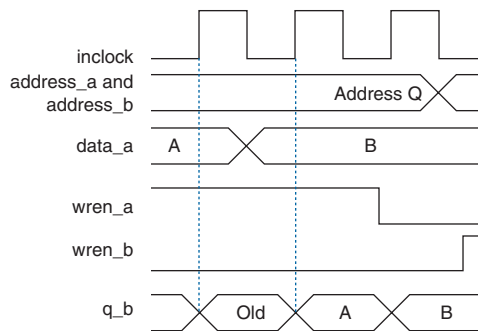

Note to Figure 8–23:

(1) Outputs are not registered.

Mixed-port read-during-write is not supported when two different clocks are used in a dual-port RAM. The output value will be unknown during a mixed-port read-during-write operation.

Conclusion

The M4K memory structure of Cyclone II devices provides a flexible memory architecture with high memory bandwidth. It addresses the needs of different memory applications in FPGA designs with features such as different memory modes, byte enables, parity bit storage, address clock enables, mixed clock mode, shift register mode, mixed-port width support, and true dual-port mode.

Introduction

Improving data bandwidth is an important design consideration when trying to enhance system performance without complicating board design. Traditionally, doubling the data bandwidth of a system required either doubling the system frequency or doubling the number of data I/O pins. Both methods are undesirable because they complicate the overall system design and increase the number of I/O pins. Using double data rate (DDR) I/O pins to transmit and receive data doubles the data bandwidth while keeping I/O counts low. The DDR architecture uses both edges of a clock to transmit data, which facilitates data transmission at twice the rate of a single data rate (SDR) architecture using the same clock speed while maintaining the same number of I/O pins. DDR transmission should be used where fast data transmission is required for a broad range of applications such as networking, communications, storage, and image processing.

Cyclone™ II devices support a broad range of external memory interfaces, such as SDR SDRAM, DDR SDRAM, DDR2 SDRAM, and QDR II SRAM. Dedicated clock delay control circuitry allows Cyclone II devices to interface with an external memory device at clock speeds up to 167 MHz/333 Mbps for DDR and DDR2 SDRAM devices and 167 MHz/667 Mbps for QDR II SRAM devices. Although Cyclone II devices also support SDR SDRAM, this chapter focuses on the implementations of a double data rate I/O interface using the hardware features available in Cyclone II devices and explains briefly how each memory standard uses the Cyclone II features.

External Memory Interface Standards

The following sections describe how to use Cyclone II device external memory interfacing features.

DDR & DDR2 SDRAM

DDR SDRAM is a memory architecture that transmits and receives data at twice the clock speed. These devices transfer data on both the rising and falling edge of the clock signal. DDR2 SDRAM is the second generation memory based on the DDR SDRAM architecture and is capable of data transfer rates of up to 533 Mbps. Cyclone II devices support DDR and DDR2 SDRAM at up to 333 Mbps.

Interface Pins

DDR and DDR2 SDRAM devices use interface pins such as data (DQ), data strobe (DQS), clock, command, and address pins to communicate with the memory controller. Data is sent and captured at twice the system clock rate by transferring data on the positive and negative edge of the clock. The commands and addresses use only one active (positive) edge of a clock.

DDR SDRAM uses single-ended data strobe DQS, while DDR2 SDRAM has the option to use differential data strobes DQS and DQS#. Cyclone II devices do not use the optional differential data strobes for DDR2 SDRAM interfaces. You can leave the DDR2 SDRAM memory DQS# pin unconnected, because only the shifted DQS signal from the clock delay control circuitry captures data. DDR and DDR2 SDRAM $\times 16$ devices use two DQS pins, and each DQS pin is associated with eight DQ pins. However, this is not the same as the $\times 16/\times 18$ mode in Cyclone II devices. You need to configure the Cyclone II devices to use two sets of pins in $\times 8$ mode. Similarly, if your $\times 72$ memory module uses nine DQS pins where each DQS pin is associated with eight DQ pins, configure the Cyclone II device to use nine sets of DQS/DQ groups in $\times 8$ mode.

Connect the memory device's DQ and DQS pins to the Cyclone II DQ and DQS pins, respectively, as listed in the Cyclone II pin tables. DDR and DDR2 SDRAM also use active-high data mask (DM) pins for writes. DM pins are pre-assigned in pin outs for Cyclone II devices, and these are the preferred pins. However, you may connect the memory device's DM pins to any of the Cyclone II I/O pins in the same bank as the DQ pins of the FPGA. There is one DM pin per DQS/DQ group. If the DDR or DDR2 SDRAM device supports ECC, the design will use an extra DQS/DQ group for the ECC pins.

You can use any of the user I/O pins for commands and addresses. Because of the symmetrical setup and hold time for the command and address pins at the memory device, you may need to generate these signals from the negative edge of the system clock.

The clocks to the SDRAM device are called CK and CK#. Use any of the user I/O pins via the DDR registers to generate the CK and CK# signals to meet the t_{DQS} requirements of the DDR SDRAM or DDR2 SDRAM device. The memory device's t_{DQS} requires the positive edge of the write DQS signal to be within 25% of the positive edge of the DDR SDRAM and DDR2 SDRAM clock input. Because of strict skew requirements between CK and CK# signals, use adjacent pins to generate the clock pair. Surround the pair with buffer pins tied to V_{CC} and pins tied to ground for better noise immunity from other signals.

Read & Write Operation

When reading from the memory, DDR and DDR2 SDRAM devices send the data edge-aligned relative to the data strobe. To properly read the data, the data strobe must be center-aligned relative to the data inside the FPGA. Cyclone II devices feature clock delay control circuitry to shift the data strobe to the middle of the data window. [Figure 9-1](#) shows an example of how the memory sends out the data and data strobe for a burst-of-two operation.

Figure 9-1. DQS Signal Center-Aligned in the LE Example

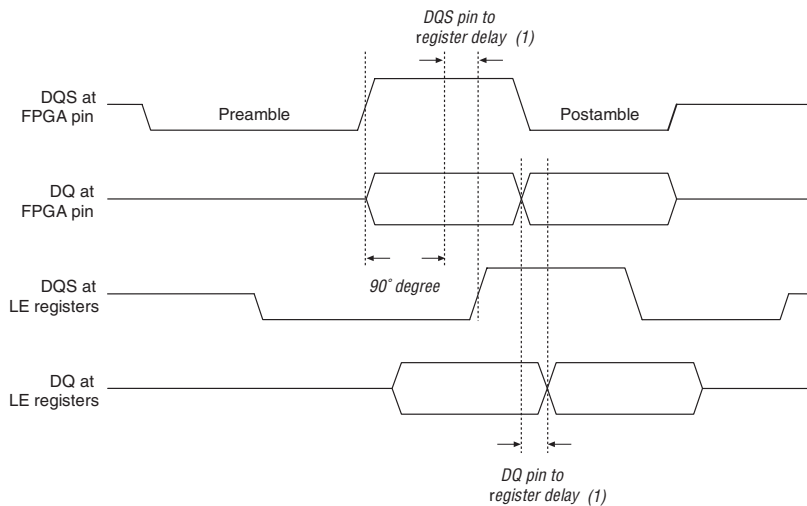

Note to [Figure 9-1](#):

(1) The DQS and DQ pins to the register delay are not the same.

During write operations to a DDR or DDR2 SDRAM device, the FPGA must send the data strobe to the memory device center-aligned relative to the data. Cyclone II devices use a PLL to center-align the data strobe by generating a 0° phase-shifted system clock for the write data strobes and a -90° phase-shifted write clock for the write data pins for the DDR and DDR2 SDRAM. [Figure 9-2](#) shows an example of the relationship between the data and data strobe during a burst-of-two write.

Figure 9–2. DQ & DQS Relationship During a DDR & DDR2 SDRAM Write

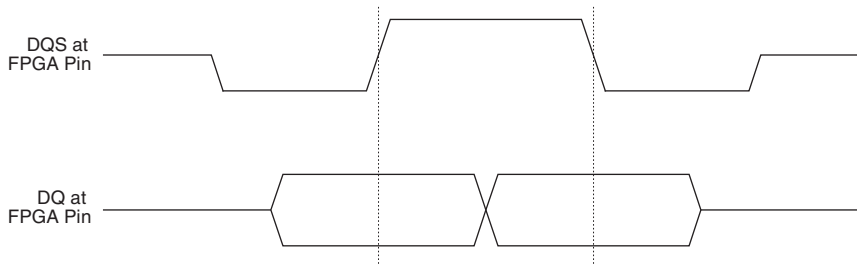

QDRII SRAM

QDRII SRAM is the second generation of QDR SRAM devices. QDRII SRAM devices, which can transfer four words per clock cycle, fulfill the requirements facing next-generation communications system designers. QDRII SRAM devices provide concurrent reads and writes, zero latency, increased data throughput, and allow simultaneous access to the same address location.

Interface Pins

QDRII SRAM devices use two separate, unidirectional data ports for read and write operations, enabling four times the data transfer compared to single data rate devices. QDRII SRAM devices use common control and address lines for read and write operations. [Figure 9–3](#) shows the block diagram for QDRII SRAM burst-of-two architecture.

Figure 9–3. QDRII SRAM Block Diagram for Burst-of-Two Architecture

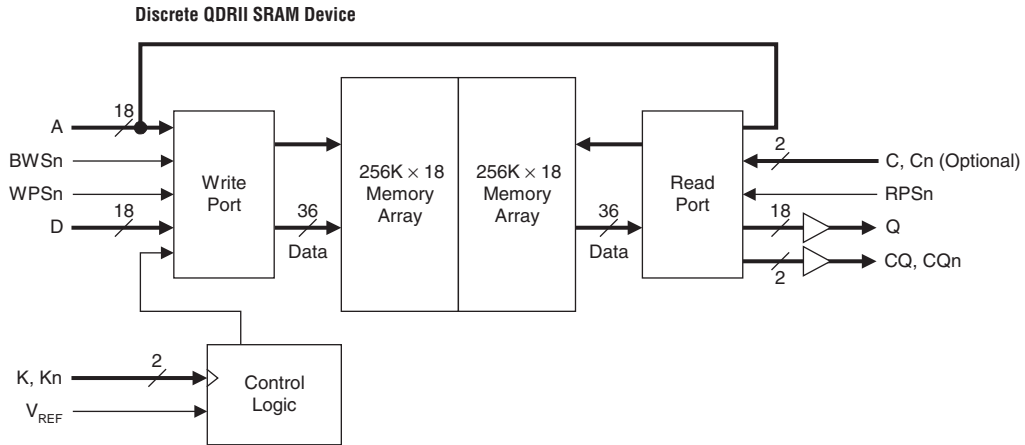

QDRII SRAM burst-of-two devices sample the read address on the rising edge of the clock and the write address on the falling edge of the clock. QDRII SRAM burst-of-four devices sample both read and write addresses on the clock's rising edge. Connect the memory device's Q ports (read data) to the Cyclone II DQ pins. You can use any of the Cyclone II device's user I/O pins in the top and bottom I/O banks for the D ports (write data), commands, and addresses. For maximum performance, Altera recommends connecting the D ports (write data) to the Cyclone II DQ pins, because the DQ pins are pre-assigned to ensure minimal skew.

QDRII SRAM devices use the following clock signals:

- Input clocks K and Kn
- Optional output clocks C and Cn
- Echo clocks CQ and CQn

Clocks Cn, Kn, and CQn are logical complements of clocks C, K, and CQ, respectively. Clocks C, Cn, K, and Kn are inputs to the QDRII SRAM, and clocks CQ and CQn are outputs from the QDRII SRAM. Cyclone II devices use single-clock mode for QDRII SRAM interfacing. The K and Kn clocks are used for both read and write operations, and the C and Cn clocks are unused.

You can generate C, Cn, K, and Kn clocks using any of the I/O registers via the DDR registers. Due to strict skew requirements between K and Kn signals, use adjacent pins to generate the clock pair. Surround the pair with buffer pins tied to V_{CC} and pins tied to ground for better noise immunity from other signals.

In Cyclone II devices, another DQS pin implements the CQn pin in the QDRII SRAM memory interface. These pins are denoted by DQS/CQ# in the pin table. Connect CQ and CQn pins to the Cyclone II DQS/CQ and DQS/CQ# pins of the same DQ groups, respectively. You must configure the DQS/CQ and DQS/CQ# as bidirectional pins. However, because CQ and CQn pins are output-only pins from the memory device, the Cyclone II device's QDRII SRAM memory interface requires that you ground the DQS/CQ and DQS/CQ# output enable. To capture data presented by the memory device, connect the shifted CQ signal to register C_T and input register A_T . Connect the shifted CQn to input register B_T .

Figure 9-4 shows the CQ and CQn connections for a QDRII SRAM read.

Figure 9-4. CQ & CQn Connection for QDRII SRAM Read

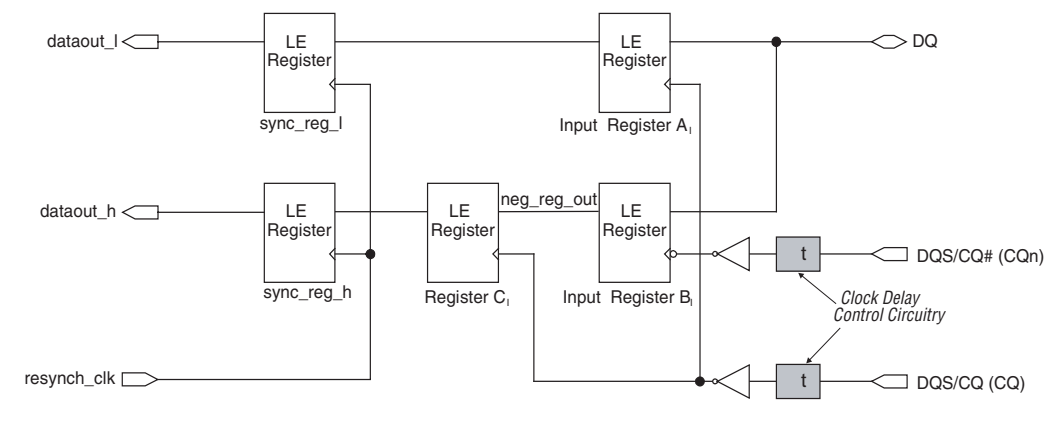

Read & Write Operation

Figure 9-5 shows the data and clock relationships in QDRII SRAM devices at the memory pins during reads. QDRII SRAM devices send data within t_{CO} time after each rising edge of the read clock C or Cn in multi-clock mode or the input clock K or Kn in single clock mode. Data is valid until t_{DOH} time after each rising edge of the read clock C or Cn in multi-clock mode or the input clock K or Kn in single clock mode. The CQ and CQn clocks are edge-aligned with the read data signal. These clocks accompany the read data for data capture in Cyclone II devices.

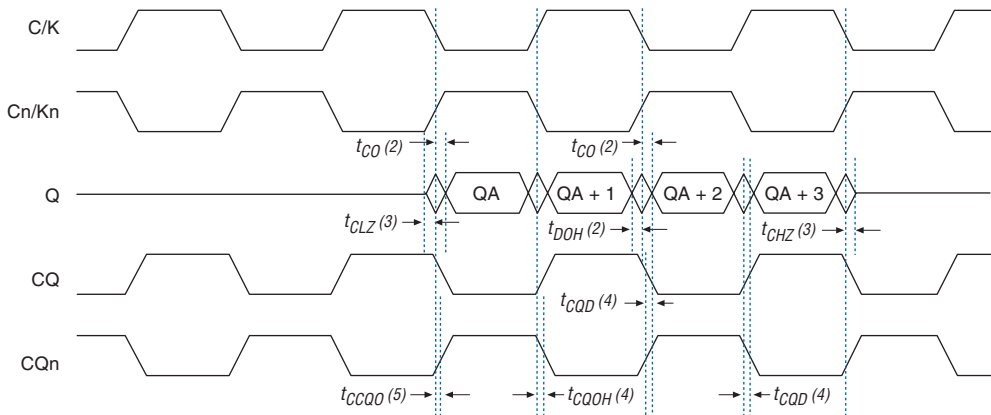
Figure 9–5. Data & Clock Relationship During a QDRII SRAM Report**Notes to Figure 9–5:**

- (1) The timing parameter nomenclature is based on the Cypress QDRII SRAM data sheet for CY7C1313V18.
- (2) t_{CO} is the data clock-to-out time and t_{DOH} is the data output hold time between burst.
- (3) t_{CLZ} and t_{CHZ} are bus turn-on and turn-off times, respectively.
- (4) t_{CQD} is the skew between CQn and data edges.
- (5) t_{CCQO} and t_{CQOH} are skew measurements between the C or Cn clocks (or the K or Kn clocks in single-clock mode) and the CQ or CQn clocks.

When writing to QDRII SRAM devices, the write clock generates the data while the K clock is 90° shifted from the write clock, creating a center-aligned arrangement.

Cyclone II DDR Memory Support Overview

Table 9–1 shows the external memory interfaces supported in Cyclone II devices.

Memory Standard	I/O Standard	Maximum Bus Width	Maximum Clock Rate Supported (MHz)	Maximum Data Rate Supported (Mbps)
DDR SDRAM	SSTL-2 class I (2)	72	167	333 (1)
	SSTL-2 class II (2)	72	133	267 (1)
DDR2 SDRAM	SSTL-18 class I (2)	72	167	333 (1)
	SSTL-18 class II (3)	72	125	250 (1)
QDRII SRAM (4)	1.8-V HSTL class I (2)	36	167	667 (1)
	1.8-V HSTL class II (3)	36	100	400 (1)

Notes to Table 9–1:

- (1) The data rate is for designs using the clock delay control circuitry.
- (2) These I/O standards are supported on all the I/O banks of the Cyclone II device.
- (3) These I/O standards are supported only on the I/O banks on the top and bottom of the Cyclone II device.
- (4) For maximum performance, Altera recommends using the 1.8-V HSTL I/O standard because of higher I/O drive strength. QDRII SRAM devices also support the 1.5-V HSTL I/O standard.

Cyclone II devices support the data strobe or read clock signal (DQS) used in DDR SDRAM with the clock delay control circuitry that can shift the incoming DQS signals to center them within the data window. To achieve DDR operation, the DDR input and output registers are implemented using the internal logic element (LE) registers. You should use the `alt_dqs` and `alt_dq` megafunctions in the Quartus® II software to implement the DDR registers used for DQS and DQ signals, respectively.

DDR Memory Interface Pins

Cyclone II devices use data (DQ), data strobe (DQS), and clock pins to interface with external memory. Figure 9–6 shows the DQ and DQS pins in the $\times 8/\times 9$ mode.

Figure 9–6. Cyclone II Device DQ & DQS Groups in $\times 8/\times 9$ Mode Notes (1), (3)

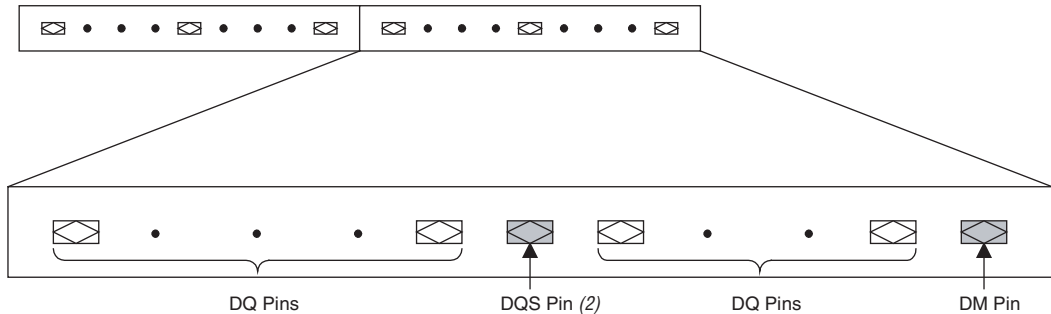

Notes to Figure 9–6:

- (1) Each DQ group consists of a DQS pin, a DM pin, and up to nine DQ pins.
- (2) For the QDRII memory interface, other DQS pins implement the CQn pins. These pins are denoted by DQS/CQn# in the pin table.
- (3) This is an idealized pin layout. For the actual pin layout, refer to the pin tables in the *PCB Layout Guidelines* section of the *Cyclone II Device Handbook, Volume 1*.

Data & Data Strobe Pins

Cyclone II data pins for the DDR memory interfaces are called DQ pins. Cyclone II devices can use either bidirectional data strobes or unidirectional read clocks. Depending on the external memory interface, either the memory device's read data strobes or read clocks feed the DQS pins.

In Cyclone II devices, all the I/O banks support DDR and DDR2 SDRAM and QDRII SRAM memory at up to 167 MHz. All the I/O banks support DQS signals with the DQ bus modes of $\times 8/\times 9$ and $\times 16/\times 18$. Cyclone II devices can support either bidirectional data strobes or unidirectional read clocks.

In $\times 8$ and $\times 16$ modes, one DQS pin drives up to 8 or 16 DQ pins, respectively, within the group. In the $\times 9$ and $\times 18$ modes, a pair of DQS pins (CQ and CQ#) drives up to 9 or 18 DQ pins within the group to support one or two parity bits and the corresponding data bits. If the parity bits or any data bits are not used, the extra DQ pins can be used as regular user I/O pins. The $\times 9$ and $\times 18$ modes are used to support the QDR II memory interface. Table 9–2 shows the number of DQS/DQ groups supported in each Cyclone II density/package combination.

Device	Package	Number of $\times 8$ Groups	Number of $\times 9$ Groups (5)	Number of $\times 16$ Groups	Number of $\times 18$ Groups (5)
EP2C5	144-pin TQFP (2)	3	3	0	0
	208-pin PQFP	7 (3)	4	3	3
EP2C8	144-pin TQFP (2)	3	3	0	0
	208-pin PQFP	7 (3)	4	3	3
	256-pin FineLine BGA®	8 (3)	4	4	4
EP2C20	256-pin FineLine BGA	8	4	4	4
	484-pin FineLine BGA	16 (4)	8	8	8
EP2C35	484-pin FineLine BGA	16 (4)	8	8	8
	672-pin FineLine BGA	20 (4)	8	8	8
EP2C50	484-pin FineLine BGA	16 (4)	8	8	8
	672-pin FineLine BGA	20 (4)	8	8	8
EP2C70	672-pin FineLine BGA	20 (4)	8	8	8
	896-pin FineLine BGA	20 (4)	8	8	8

Notes to Table 9–2:

- (1) Numbers are preliminary.
- (2) EP2C5 and EP2C8 devices in the 144-pin TQFP package do not have any DQ pin groups in I/O bank 1.
- (3) Because of available clock resources, only a total of 6 DQ/DQS groups can be implemented.
- (4) Because of available clock resources, only a total of 14 DQ/DQS groups can be implemented.
- (5) The $\times 9$ DQS/DQ groups are also used as $\times 8$ DQS/DQ groups. The $\times 18$ DQS/DQ groups are also used as $\times 16$ DQS/DQ groups.

The DQS pins are listed in the Cyclone II pin tables as DQS [1 . . 0] T, DQS [1 . . 0] B, DQS [1 . . 0] L, and DQS [1 . . 0] R for the EP2C5 and EP2C8 devices and DQS [5 . . 0] T, DQS [5 . . 0] B, DQS [3 . . 0] L, and DQS [3 . . 0] R for the larger devices. The T denotes pins on the top of the device, the B denotes pins on the bottom of the device, the L denotes pins on the left of the device, and the R denotes pins on the right of the device. The corresponding DQ pins are marked as DQ [5 . . 0] T [8 . . 0], where [5 . . 0] indicates which DQS group the pins belong to.

In the Cyclone II pinouts, the DQ groups with 9 DQ pins are also used in the $\times 8$ mode with the corresponding DQS pins, leaving the unused DQ pin available as a regular I/O pin. The DQ groups that have 18 DQ pins are also used in the $\times 16$ mode with the corresponding DQS pins, leaving the two unused DQ pins available as regular I/O pins. For example, DQ1T [8 . . 0] can be used in the $\times 8$ mode, provided it is used with DQS1T. The remaining unused DQ pin, DQ1T8, is available as a regular I/O pin.

When not used as DQ or DQS pins, these pins are available as regular I/O pins. Table 9–3 shows the number of DQS pins supported in each I/O bank in each Cyclone II device density.

Device	Top I/O Bank	Bottom I/O Bank	Left I/O Bank	Right I/O Bank
EP2C5, EP2C8	DQS [1 . . 0] T	DQS [1 . . 0] B	DQS [1 . . 0] L	DQS [1 . . 0] R
EP2C20, EP2C35, EP2C50, EP2C70	DQS [5 . . 0] B	DQS [5 . . 0] T	DQS [3 . . 0] L	DQS [3 . . 0] R

Note to Table 9–3:

(1) Numbers are preliminary.

The DQ pin numbering is based on $\times 8/\times 9$ mode. There are up to 8 DQS/DQ groups in $\times 8$ mode or 4 DQS/DQ groups in $\times 9$ mode in I/O banks for EP2C5 and EP2C8. For the larger devices, there are up to 20 DQS/DQ groups in $\times 8$ mode or 8 DQS/DQ groups in $\times 9$ mode. There are up to 20 DQS/DQ groups in the $\times 8$ mode available in the larger Cyclone II devices, but because of the available clock resources in the Cyclone II devices, only 16 DQS/DQ groups can be utilized for the external memory interface. Although there is a total of 16 global clock buses available for routing DQS signals, 2 of them are already used for routing the -90° write clock and the system clock to the external memory devices. This reduces the global clock resources to 14 global clock buses for routing DQS signals. Incoming DQS signals are all routed to the clock control block, and are then routed to the global clock bus to clock the DDR LE registers. For EP2C5 and EP2C8 devices, the DQS signals are routed directly to the clock control block. For the larger Cyclone II devices, the corner DQS signals are multiplexed before they are routed to the clock control block. When you use the corner DQS pins for DDR implementation, there is a degradation in the performance of the memory interface. The clock control block is used to select from a number of input clock sources, in this case either PLL clock outputs or DQS pins, to drive onto the global clock bus. Figure 9–7 shows the corner DQS signal mappings for EP2C20 through EP2C70 devices.

Figure 9–7. Corner DQS Signal Mapping for EP2C20–EP2C70 Devices

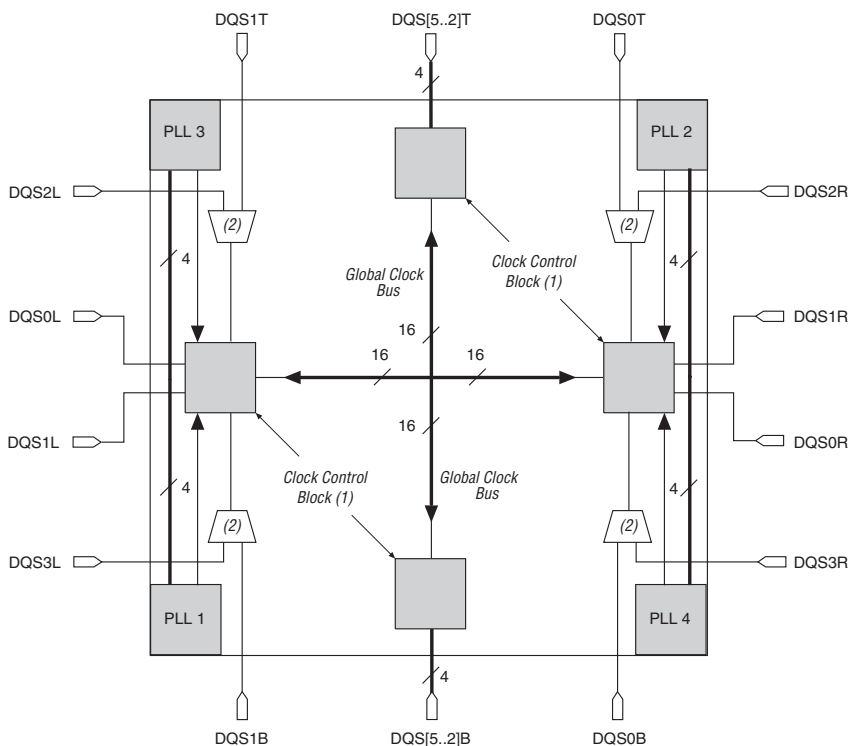

Notes to Figure 9–7:

- (1) There are four clock control blocks on each side.
- (2) Only one of the corner DQS pins in each corner can feed the clock control block at a time. The other DQS pins can be used as general purpose I/O pins.

For example, to implement a 72-bit wide SDRAM memory interface in Cyclone II devices, use 5 DQS/DQ groups in the top I/O bank and 4 DQS/DQ groups in the bottom I/O bank, or vice-versa. In this case, if DQS0T or DQS1T is used for the fifth DQS signal, the DQS2R or DQS2L pins become regular I/O pins and are unavailable for DQS signals in memory interface. For detailed information about the global clock network, refer to the *Global Clock Network & Phase Locked Loops* section in the *Cyclone II Architecture* chapter of the *Cyclone II Device Handbook*.

You must configure the DQ and DQS pins as bidirectional DDR pins on all the I/O banks of the device. Use the `altdq` and `altdqs` megafunctions to configure the DQ and DQS paths, respectively. If you only want to use the DQ or DQS pins as inputs, for instance in the QDRII memory interface where DQ and DQS are unidirectional read data and read clock, set the output enable of the DQ or DQS pins to ground. For further information, please refer to the section “QDRII SRAM” on page 9–4 of this handbook.

Clock, Command & Address Pins

You can use any of the user I/O pins on all the I/O banks (that support the external memory’s I/O standard) of the device to generate clocks and command and address signals to the memory device.

Parity, DM & ECC Pins

You can use any of the DQ pins for the parity pins in Cyclone II devices. Cyclone II devices support parity in the $\times 8/\times 9$ and $\times 16/\times 18$ modes. There is one parity bit available per 8 bits of data pins.

The data mask (DM) pins are required when writing to DDR SDRAM and DDR2 SDRAM devices. A low signal on the DM pin indicates that the write is valid. If the DM signal is high, the memory masks the DQ signals. In Cyclone II devices, the DM pins are pre-assigned in the device pin outs, and these are the preferred pins. Each group of DQS and DQ signals requires a DM pin. Similar to the DQ output signals, the DM signals are clocked by the -90° shifted clock.

Some DDR SDRAM and DDR2 SDRAM devices support error correction coding (ECC) or parity. Parity bit checking is a way to detect errors, but it has no correction capabilities. ECC can detect and automatically correct errors in data transmission. In 72-bit DDR SDRAM, there are 8 ECC pins on top of the 64 data pins. Connect the DDR and DDR2 SDRAM ECC pins to a Cyclone II device’s DQS/DQ group. The memory controller needs extra logic to encode and decode the ECC data.

Phase Lock Loop (PLL)

When using the Cyclone II I/O banks to interface with the DDR memory, at least one PLL with two outputs is needed to generate the system clock and the write clock. The system clock generates the DQS write signals, commands, and addresses. The write clock shifts by -90° from the system clock and generates the DQ signals during writes.

Clock Delay Control

Clock delay control circuit on each DQS pin allows a phase shift that center-aligns the incoming DQS signals within the data window of their corresponding DQ data signals. The phase-shifted DQS signals drive the global clock network. This global DQS signal then clocks the DQ signals on internal LE registers. The clock delay control circuitry is used during the read operations where the DQS signals are acting as input clocks or strobes.

Figure 9–8 illustrates DDR SDRAM interfacing from the I/O pins through the dedicated circuitry to the logic array.

Figure 9–8. DDR SDRAM Interfacing

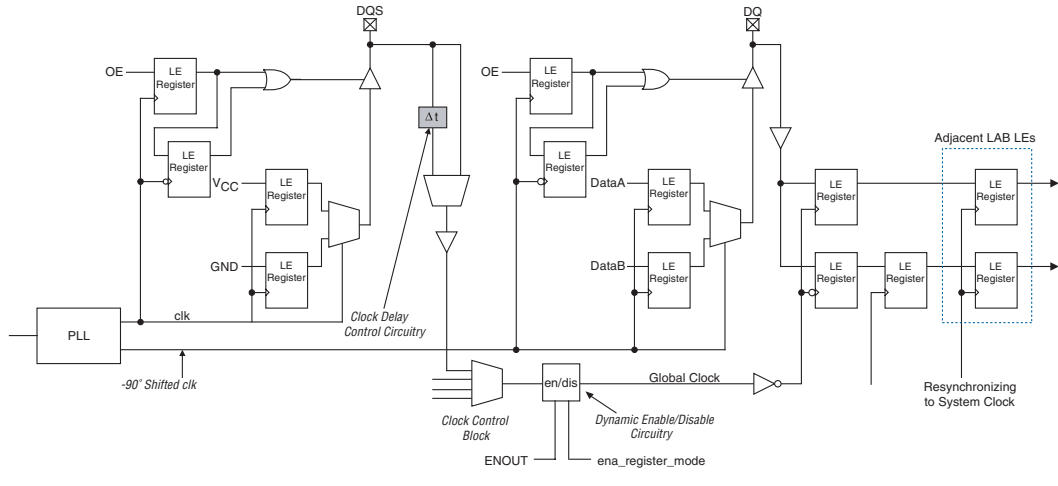

Figure 9–1 on page 9–3 shows an example where the DQS signal is shifted by 90°. The DQS signal goes through the 90° shift delay set by the clock delay control circuitry and global clock routing delay from the clock delay control circuitry to the DQ LE registers. The DQ signals only go through routing delays from the DQ pin to the DQ LE registers. The delay from DQS pin to the DQ LE register does not necessarily match the delay from the DQ pin to the DQ LE register. Therefore, you must adjust the clock delay control circuitry to compensate for this difference in delays.

DQS Postamble

For external memory interfaces that use a bidirectional read strobe, such as DDR and DDR2 SDRAM, the DQS signal is low before going to or coming from the high-impedance state (see [Figure 9-1](#)). The state where DQS is low just after high-impedance is called the preamble and the state where DQS is low just before it goes to high-impedance is called the postamble. There are preamble and postamble specifications for both read and write operations in DDR and DDR2 SDRAM. If the Cyclone II device or the DDR/DDR2 SDRAM device does not drive the DQ and DQS pins, the signals go to a high-impedance state. Because a pull-up resistor terminates both DQ and DQS to V_{TT} (1.25 V for SSTL-2 and 0.9 V for SSTL-18), the effective voltage on the high-impedance line is either 1.25 V or 0.9 V. According to the JEDEC JESD8-9 specification for SSTL-2 I/O standard and the JESD8-15A specification for SSTL-18 I/O standard, this is an indeterminate logic level, and the input buffer can interpret this as either a logic high or logic low. If there is any noise on the DQS line, the input buffer may interpret that noise as actual strobe edges.

The DQS postamble circuitry ensures data is not lost when there is noise on the DQS line at the end of a read postamble time. The DQS postamble circuitry is a dynamic enable/disable circuit that resides after the clock control block (see [Figure 9-8](#)). During configuration of the `alt_dqs` megafunction, when the DQS postamble circuitry is enabled, the `ena_register_mode` bit is set to route the `ENOUT` signal directly to control the output of the global clock, as indicated by the highlighted path in [Figure 9-9](#).

Figure 9-9. Dynamic Enable/Disable Circuitry

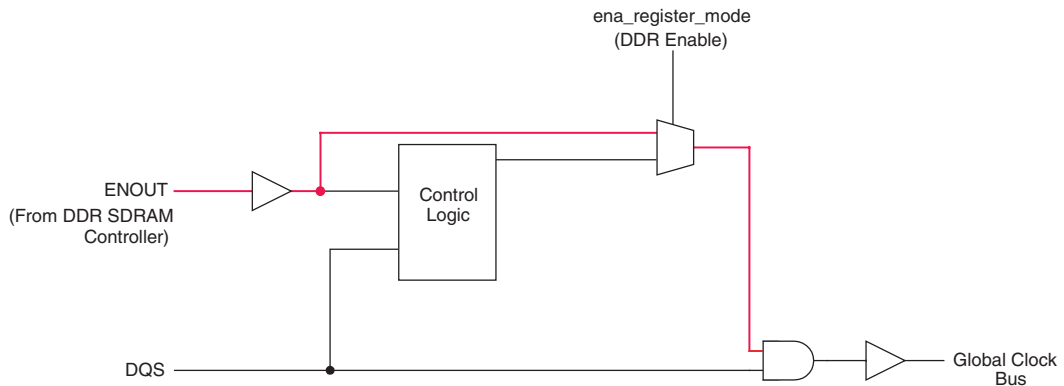

Note to [Figure 9-9](#):

- (1) The device uses the red path during the configuration of the `alt_dqs` megafunction, when the DQS postamble circuitry is enabled.

Upon sensing the last DQS falling edge, the DDR or DDR2 SDRAM controller sends out the ENOUT signal to disable the DQS signal going to the global clock bus. This ensures that any glitches on the DQS input signals at the end of the read postamble time do not affect the DQ LE registers (see [Figure 9–10](#)).

Figure 9–10. Dynamic Enable/Disable Circuitry Control Timing Waveform

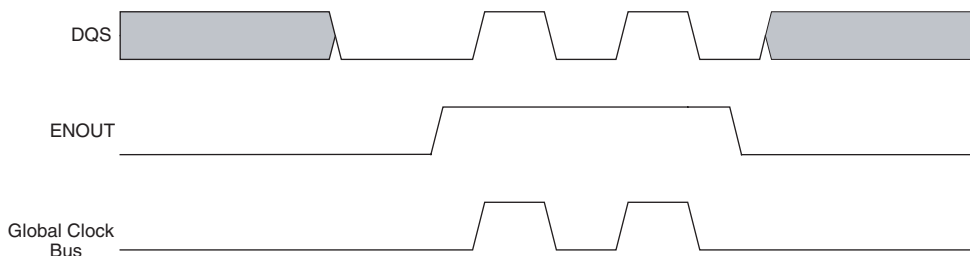

The shifted DQS signal then goes to the global clock bus to clock the LE input registers of the DQ pins. It can also go into the logic array for resynchronization purposes to interface with memory interfaces that use continuously running read clocks.

DDR Input Registers

In Cyclone II devices, the DDR input registers are implemented with five internal LE registers located in the logic array block (LAB) adjacent to the DDR input pin (see [Figure 9–11](#)). The DDR data is fed to the first two registers, input register A_T and input register B_T . Input register B_T captures the DDR data present during the rising edge of the clock. Input register A_T captures the DDR data present during the falling edge of the clock. Register C_T aligns the data before it is transferred to the resynchronization registers.

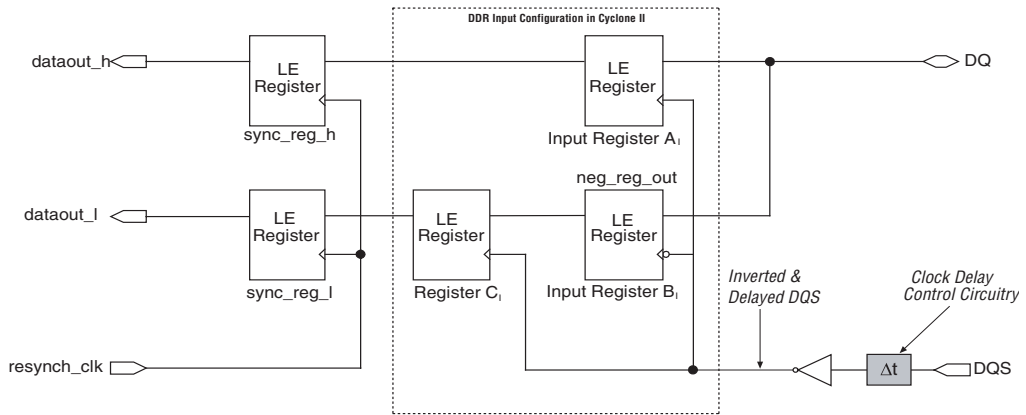
Figure 9–11. DDR Input Implementation

Registers `sync_reg_h` and `sync_reg_l` synchronize the two data streams to the rising edge of the resynchronization clock. [Figure 9–12](#) shows examples of functional waveforms from a double data rate input implementation.

Figure 9–12. DDR Input Functional Waveforms

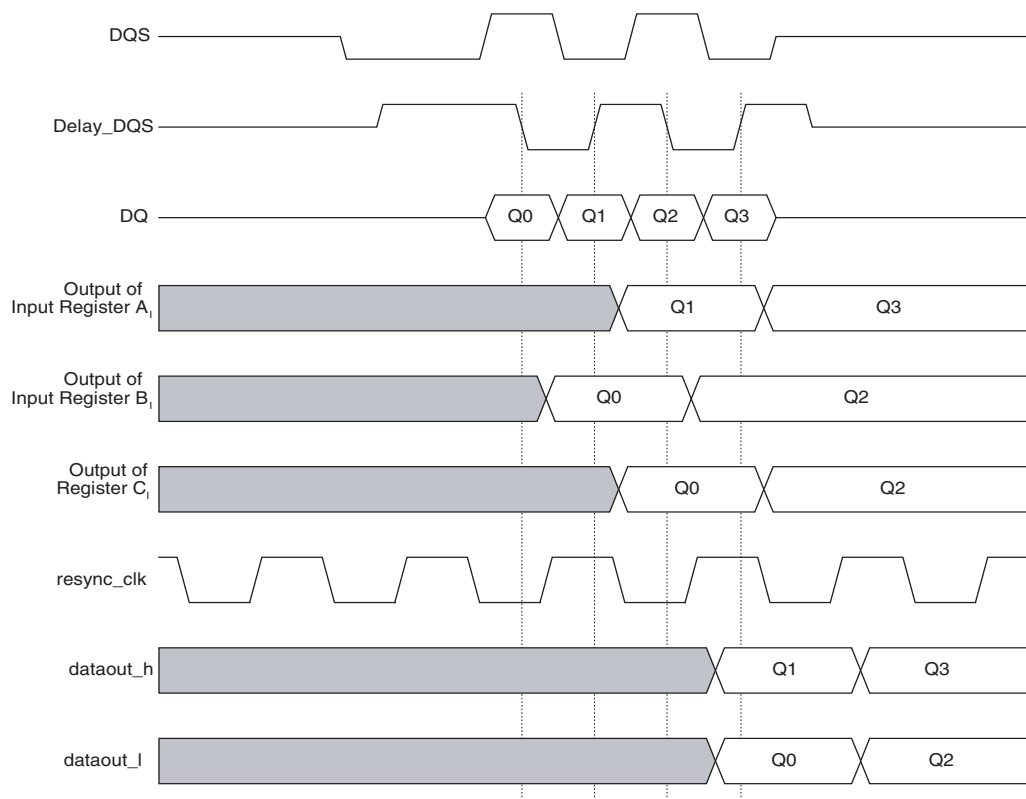

The Cyclone II DDR input registers require you to invert the incoming DQS signal to ensure proper data transfer. The `altddq` megafunction automatically adds the inverter on the clock port of the DQ signals. As shown in Figure 9–11, the inverted DQS signal's rising edge clocks register A_I, its falling edge clocks register B_I, and register C_I aligns the data clocked by register B_I with register A_I on the inverted DQS signal's rising edge. In a DDR memory read operation, the last data coincides with the falling edge of DQS signal. If you do not invert the DQS pin, you will not get this last data because the register does not latch until the next rising edge of the DQS signal.

Figure 9–13 shows waveforms of the circuit shown in Figure 9–11. The first set of waveforms in Figure 9–13 shows the edge-aligned relationship between the DQ and DQS signals at the Cyclone II device pins. The second set of waveforms in Figure 9–13 shows what happens if the shifted DQS signal is not inverted. In this case, the last data, Q_n , does not get latched into the logic array as DQS goes to tri-state after the read postamble time. The third set of waveforms in Figure 9–13 shows a proper read operation with the DQS signal inverted after the 90° shift. The last data, Q_n , does get latched. In this case the outputs of register A_I and register C_I , which correspond to `dataout_h` and `dataout_l` ports, are now switched because of the DQS inversion. Register A_I , register B_I , and register C_I refer to the nomenclature in Figure 9–11 on page 9–17.

Figure 9–13. DQ Captures With Noninverted & Inverted Shifted DQS

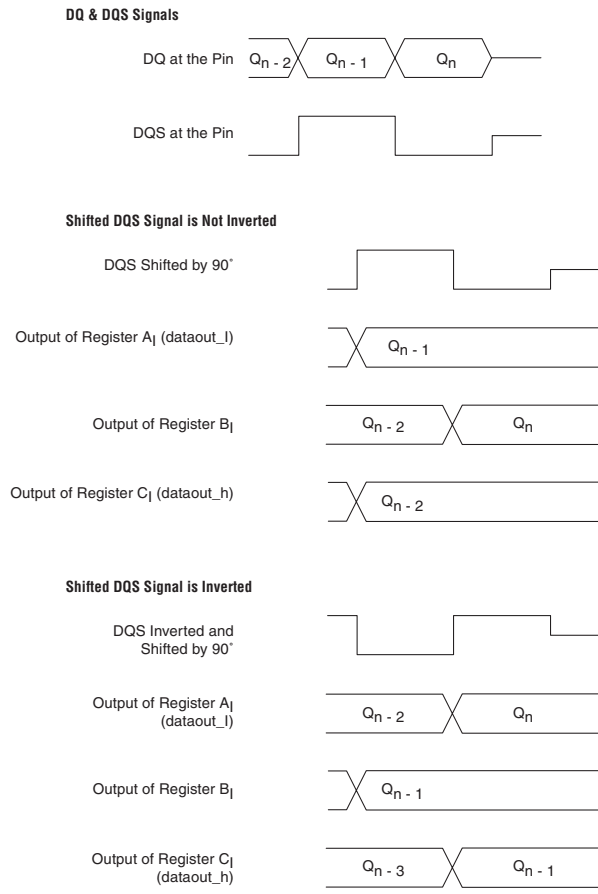

DDR Output Registers

Figure 9–14 shows a schematic representation of DDR output implemented in a Cyclone II device. The DDR output logic is implemented using LEs in the LAB adjacent to the output pin. Two registers synchronize two serial data streams. The registered outputs are then multiplexed by the common clock to drive the DDR output pin at two times the data rate.

Figure 9–14. DDR Output Implementation for DDR Memory Interfaces

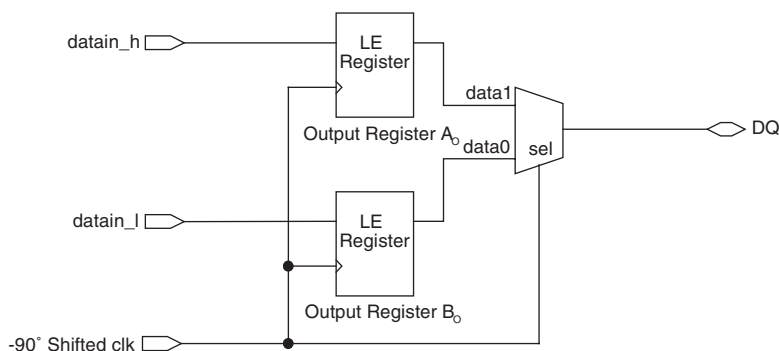

While the clock signal is logic-high, the output from output register `A0` is driven onto the DDR output pin. While the clock signal is logic-low, the output from output register `B0` is driven onto the DDR output pin. The DDR output pin can be any available user I/O pin. Use the `altdq` and `altdqs` megafunctions to implement this output logic. This automatically provides the required tight placement and routing constraints on the LE registers and the output multiplexer to prevent large glitches from appearing on the DDR output pin.

Figure 9–15 shows examples of functional waveforms from a DDR output implementation.

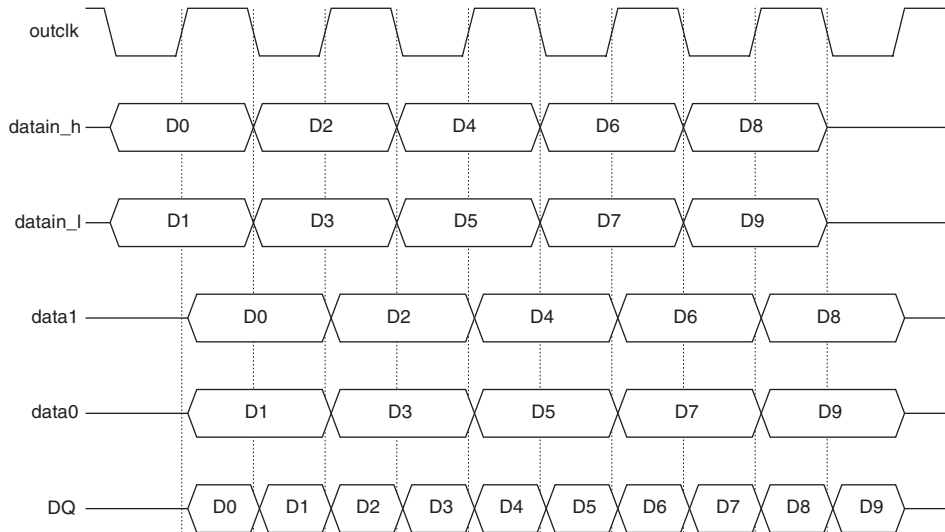
Figure 9–15. DDR Output Waveforms

Bidirectional DDR Registers

Figure 9–16 shows a bidirectional DDR interface constructed using the DDR input and DDR output examples described in the previous two sections. As with the DDR input and DDR output examples, the bidirectional DDR pin can be any available user I/O pin. The registers that implement DDR bidirectional logic are LEs in the LAB adjacent to that pin. The tri-state buffer controls when the device drives data onto the bidirectional DDR pin.

Figure 9–16. Bidirectional DDR Implementation for DDR Memory Interfaces *Note (1)*

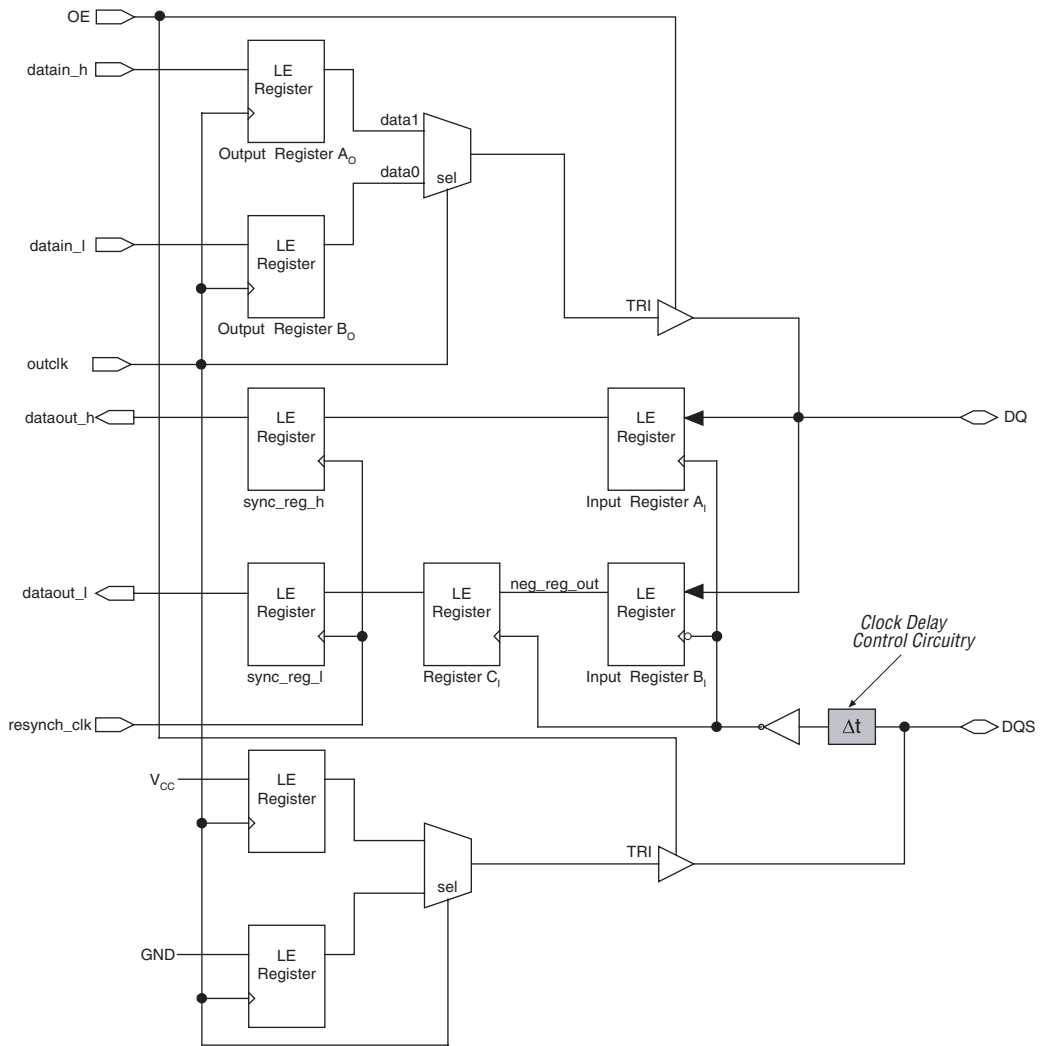

Note to Figure 9–16:

(1) You can use the `altdq` and `altdqs` megafunctions to generate the DQ and DQS signals.

Figure 9–17 shows example waveforms from a bidirectional DDR implementation.

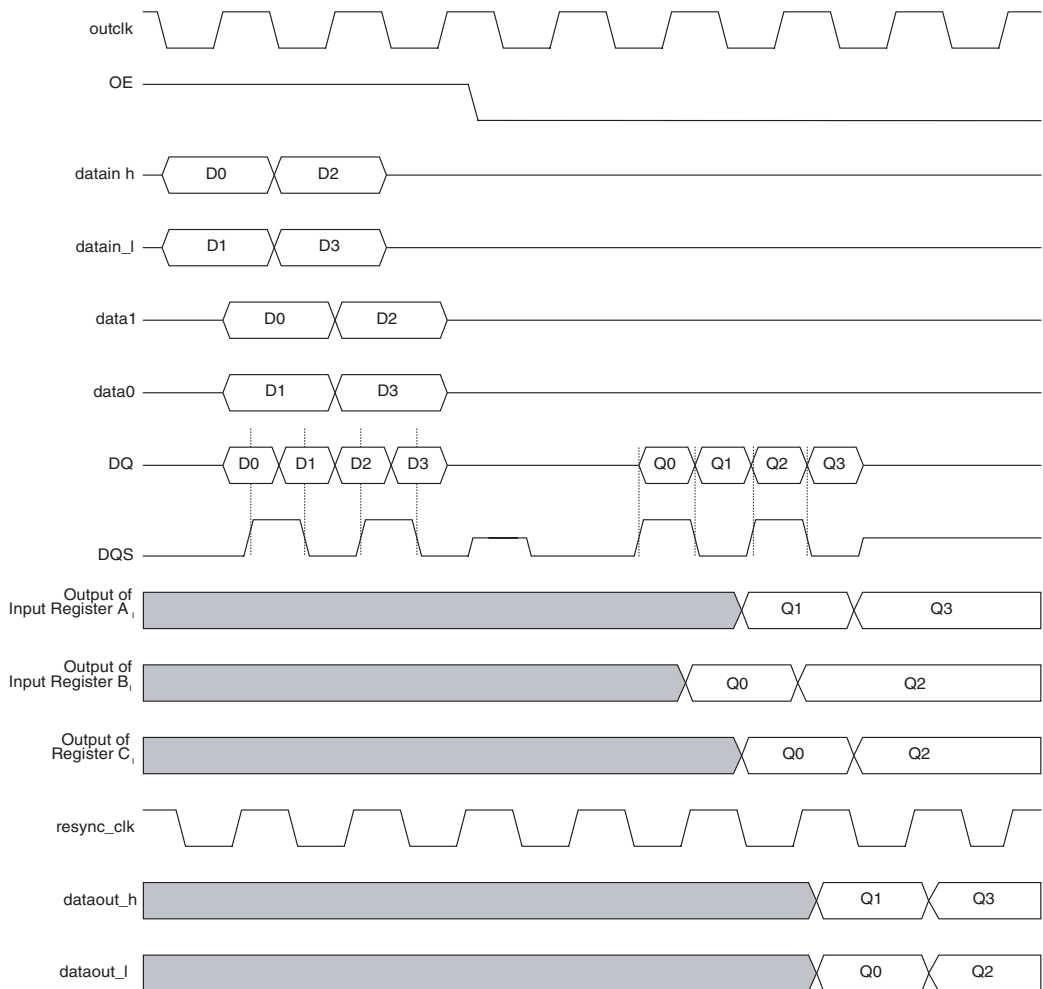
Figure 9–17. DDR Bidirectional Waveforms

Conclusion

Cyclone II devices support SDR SDRAM, DDR SDRAM, DDR2 SDRAM, and QDR II SRAM external memories. Cyclone II devices feature high-speed interfaces that transfer data between external memory devices at up to 167 MHz/333 Mbps for DDR and DDR2 SDRAM devices and 167 MHz/667 Mbps for QDR II SRAM devices. The clock delay control circuitry allows you to fine tune the phase shift for the input clocks or strobes to properly align clock edges as needed to capture data.

This section provides information on Cyclone™ II single-ended, voltage referenced, and differential I/O standards.

This section includes the following chapters:

- Chapter 10, Selectable I/O Standards in Cyclone II Devices
- Chapter 11, High-Speed Differential Interfaces in Cyclone II Devices

Revision History

The table below shows the revision history for Chapters 10 and 11.

Chapter(s)	Date / Version	Changes Made
10	November 2004, v1.1	Updated Table 10–7.
	June 2004, v1.0	Added document to the Cyclone II Device Handbook.
11	November 2004, v1.1	<ul style="list-style-type: none"> ● Updated Table 11–1. ● Updated Figures 11–4, 11–5, 11–7, and 11–8.
	June 2004, v1.0	Added document to the Cyclone II Device Handbook.

Introduction

The proliferation of I/O standards and the need for improved I/O performance have made it critical that low-cost devices have flexible I/O capabilities. Selectable I/O capabilities such as SSTL-18, SSTL-2, and LVDS compatibility allow Cyclone™ II devices to connect to other devices on the same printed circuit board (PCB) that may require different operating and I/O voltages. With these aspects of implementation easily manipulated using the Altera® Quartus® II software, the Cyclone II device family enables system designers to use low cost FPGAs while keeping pace with increasing design complexity.

This chapter is a guide to understanding the input and output capabilities of the Cyclone II devices, including:

- Supported I/O standards
- Cyclone II I/O banks
- Programmable current drive strength
- I/O termination
- Pad placement and DC guidelines



For information on hot socketing, see the *Hot Socketing, ESD & Power-On Reset* chapter in Volume 1 of the *Cyclone II Device Handbook*.

Supported I/O Standards

Cyclone II devices support the I/O standards shown in [Table 10-1](#).



See the *DC Characteristics & Timing Specifications* chapter in Volume 1 of the *Cyclone II Device Handbook*, for more details on the I/O standards discussed in this section, including target data rates and voltage values for each I/O standard.



See the *External Memory Interfaces in Cyclone II Devices* chapter in Volume 1 of the *Cyclone II Device Handbook* for information on the I/O standards supported for external memory applications.

Table 10–1. Cyclone II Supported I/O Standards & Constraints (Part 1 of 2)

I/O Standard	Type	V _{CCIO} Level		Top & Bottom I/O Pins		Side I/O Pins		
		Input	Output	CLK, DQS	User I/O Pins	CLK, DQS	PLL_OUT	User I/O Pins
3.3-V LVTTTL and LVCMOS	Single ended	3.3 V / 2.5 V	3.3 V	✓	✓	✓	✓	✓
2.5-V LVTTTL and LVCMOS	Single ended	3.3 V / 2.5 V	2.5 V	✓	✓	✓	✓	✓
1.8-V LVTTTL and LVCMOS	Single ended	1.8 V / 1.5 V	1.8 V	✓	✓	✓	✓	✓
1.5-V LVCMOS	Single ended	1.8 V / 1.5 V	1.5 V	✓	✓	✓	✓	✓
SSTL-2 class I	Voltage referenced	2.5 V	2.5 V	✓	✓	✓	✓	✓
SSTL-2 class II	Voltage referenced	2.5 V	2.5 V	✓	✓	✓	✓	✓
SSTL-18 class I	Voltage referenced	1.8 V	1.8 V	✓	✓	✓	✓	✓
SSTL-18 class II	Voltage referenced	1.8 V	1.8 V	✓	✓	(1)	(1)	(1)
HSTL-18 class I	Voltage referenced	1.8 V	1.8 V	✓	✓	✓	✓	✓
HSTL-18 class II	Voltage referenced	1.8 V	1.8 V	✓	✓	(1)	(1)	(1)
HSTL-15 class I	Voltage referenced	1.5 V	1.5 V	✓	✓	✓	✓	✓
HSTL-15 class II	Voltage referenced	1.5 V	1.5 V	✓	✓	(1)	(1)	(1)
PCI and PCI-X (2)	Single ended	3.3 V	3.3 V			✓	✓	✓
Differential SSTL-2 class I or class II	Pseudo differential (3)	(4)	2.5 V				✓	
		2.5 V	(4)	✓ (5)		✓ (5)		
Differential SSTL-18 class I or class II	Pseudo differential (3)	(4)	1.8 V				✓ (6)	
		1.8 V	(4)	✓ (5)		✓ (5)		

Table 10–1. Cyclone II Supported I/O Standards & Constraints (Part 2 of 2)

I/O Standard	Type	V _{CCIO} Level		Top & Bottom I/O Pins		Side I/O Pins		
		Input	Output	CLK, DQS	User I/O Pins	CLK, DQS	PLL_OUT	User I/O Pins
Differential HSTL-15 class I or class II	Pseudo differential (3)	(4)	1.5 V				✓ (6)	
		1.5 V	(4)	✓ (5)		✓ (5)		
Differential HSTL-18 class I or class II	Pseudo differential (3)	(4)	1.8 V				✓ (6)	
		1.8 V	(4)	✓ (5)		✓ (5)		
LVDS	Differential	2.5 V	2.5 V	✓	✓	✓	✓	✓
RSDS and mini-LVDS (7)	Differential	(4)	2.5 V		✓		✓	✓
LVPECL (8)	Differential	3.3 V/ 2.5 V/ 1.8 V/ 1.5 V	(4)		✓		✓	

Notes to Table 10–1:

- (1) These pins support SSTL-18 class II and 1.8- and 1.5-V HSTL class II inputs.
- (2) PCI-X does not meet the IV curve requirement at the linear region. PCI-clamp diode is not available on top and bottom I/O pins.
- (3) Pseudo-differential HSTL and SSTL outputs use two single-ended outputs with the second output programmed as inverted. Pseudo-differential HSTL and SSTL inputs treat differential inputs as two single-ended HSTL and SSTL inputs and only decode one of them.
- (4) This I/O standard is not supported on these I/O pins.
- (5) This I/O standard is only supported on the dedicated clock pins.
- (6) PLL_OUT does not support differential SSTL-18 class II and differential 1.8 and 1.5-V HSTL class II.
- (7) mini-LVDS and RSDS are only supported on output pins.
- (8) LVPECL is only supported on clock inputs.

3.3-V LVTTTL (EIA/JEDEC Standard JESD8-B)

The 3.3-V LVTTTL I/O standard is a general-purpose, single-ended standard used for 3.3-V applications. The LVTTTL standard defines the DC interface parameters for digital circuits operating from a 3.0-/3.3-V power supply and driving or being driven by LVTTTL-compatible devices.

The LVTTTL input standard specifies a wider input voltage range of $-0.3\text{ V} \leq V_I \leq 3.9\text{ V}$. Altera recommends an input voltage range of $-0.5\text{ V} \leq V_I \leq 4.1\text{ V}$.

3.3-V LVCMOS (EIA/JEDEC Standard JESD8-B)

The 3.3-V LVCMOS I/O standard is a general-purpose, single-ended standard used for 3.3-V applications. The LVCMOS standard defines the DC interface parameters for digital circuits operating from a 3.0- or 3.3-V power supply and driving or being driven by LVCMOS-compatible devices.

The LVCMOS standard specifies the same input voltage requirements as LVTTTL ($-0.3\text{ V} \leq V_I \leq 9\text{ V}$). The output buffer drives to the rail to meet the minimum high-level output voltage requirements. The 3.3-V I/O standard does not require input reference voltages or board terminations. Cyclone II devices support both input and output levels specified by the 3.3-V LVCMOS I/O standard.

3.3-V (PCI Special Interest Group [SIG] PCI Local Bus Specification Revision 3.0)

The PCI local bus specification is used for applications that interface to the PCI local bus, which provides a processor-independent data path between highly integrated peripheral controller components, peripheral add-in boards, and processor/memory systems. The conventional PCI specification revision 3.0 defines the PCI hardware environment including the protocol, electrical, mechanical, and configuration specifications for the PCI devices and expansion boards. This standard requires a 3.3-V V_{CCIO} . The 3.3-V PCI standard does not require input reference voltages or board terminations.

The side (left and right) I/O banks on all Cyclone II devices are fully compliant with the *3.3V PCI Local Bus Specification Revision 3.0* and meet 32-bit/66 MHz operating frequency and timing requirements.

Table 10–2 lists the specific Cyclone II devices that support 64- and 32-bit PCI at 66 MHz.

<i>Table 10–2. Cyclone II 66-MHz PCI Support (Part 1 of 2)</i>			
Device	Package	-6 & -7 Speed Grades	
		64 Bits	32 Bits
EP2C5	144-pin TQFP		
	208-pin PQFP		✓
EP2C8	144-pin TQFP		
	208-pin PQFP		✓
	256-pin FineLine BGA®		✓

Table 10–2. Cyclone II 66-MHz PCI Support (Part 2 of 2)

Device	Package	-6 & -7 Speed Grades	
		64 Bits	32 Bits
EP2C20	256-pin FineLine BGA		✓
	484-pin FineLine BGA	✓	✓
EP2C35	484-pin FineLine BGA	✓	✓
	672-pin FineLine BGA	✓	✓
EP2C50	484-pin FineLine BGA	✓	✓
	672-pin FineLine BGA	✓	✓
EP2C70	672-pin FineLine BGA	✓	✓
	896-pin FineLine BGA	✓	✓

Table 10–3 lists the specific Cyclone II devices that support 64-bit and 32-bit PCI at 33 MHz.

Table 10–3. Cyclone II 33-MHz PCI Support

Device	Package	-6, -7 & -8 Speed Grades	
		64 Bits	32 Bits
EP2C5	144-pin TQFP		
	208-pin PQFP		✓
EP2C8	144-pin TQFP		
	208-pin PQFP		✓
	256-pin FineLine BGA		✓
EP2C20	256-pin FineLine BGA		✓
	484-pin FineLine BGA	✓	✓
EP2C35	484-pin FineLine BGA	✓	✓
	672-pin FineLine BGA	✓	✓
EP2C50	484-pin FineLine BGA	✓	✓
	672-pin FineLine BGA	✓	✓
EP2C70	672-pin FineLine BGA	✓	✓
	896-pin FineLine BGA	✓	✓

3.3-V PCI-X

The 3.3-V PCI-X I/O standard is formulated under PCI-X Local Bus Specification Revision 1.0 developed by the PCI SIG.

The PCI-X 1.0 standard is used for applications that interface to the PCI local bus. The standard enables the design of systems and devices that operate at clock speeds up to 133 MHz, or 1 gigabit per second (Gbps) for a 64-bit bus. The PCI-X 1.0 protocol enhancements enable devices to operate much more efficiently, providing more usable bandwidth at any clock frequency. By using the PCI-X 1.0 standard, devices can be designed to meet PCI-X 1.0 requirements and operate as conventional 33- and 66-MHz PCI devices when installed in those systems. This standard requires 3.3-V V_{CCIO} . Cyclone II devices are fully compliant with the 3.3-V PCI-X Specification Revision 1.0a and meet the 133 MHz operating frequency and timing requirements. The 3.3-V PCI-X standard does not require input reference voltages or board terminations. Cyclone II devices support both input and output levels operation for horizontal I/O banks.

2.5-V LVTTTL Normal & Wide Voltage Ranges (EIA/JEDEC Standard EIA/JESD8-5)

The 2.5-V I/O standard is used for 2.5-V LVTTTL applications. This standard defines the DC interface parameters for high-speed, low-voltage, non-terminated digital circuits driving or being driven by other 2.5-V devices. The input and output voltage requirements are:

- The 2.5-V normal and wide range input standards specify an input voltage range of $-0.3\text{ V} \leq V_1 \leq 3.0\text{ V}$.
- The normal range minimum high-level output voltage requirement (V_{OH}) is 2.1 V.
- The wide range minimum V_{OH} is $V_{CCIO} - 0.2\text{ V}$.

The 2.5-V standard does not require input reference voltages or board terminations. Cyclone II devices support input and output levels for both 2.5-V LVTTTL ranges.

2.5-V LVC MOS Normal & Wide Voltage Ranges (EIA/JEDEC Standard EIA/JESD8-5)

The 2.5-V I/O standard is used for 2.5-V LVC MOS applications. This standard defines the DC interface parameters for high-speed, low-voltage, non-terminated digital circuits driving or being driven by other 2.5-V parts. The input and output voltage ranges are:

- The 2.5-V normal and wide range input standards specify an input voltage range of $-0.3 \text{ V} \leq V_I \leq 3.0 \text{ V}$.
- The normal range minimum V_{OH} requirement is 2.1 V.
- The wide range minimum V_{OH} requirement is $V_{CCIO} - 0.2 \text{ V}$.

The 2.5-V standard does not require input reference voltages or board terminations. Cyclone II devices support input and output levels for both 2.5-V LVC MOS ranges.

SSTL-2 Class I & II (EIA/JEDEC Standard JESD8-9A)

The SSTL-2 I/O standard is a 2.5-V memory bus standard used for applications such as high-speed double data rate (DDR) SDRAM interfaces. This standard defines the input and output specifications for devices that operate in the SSTL-2 logic switching range of 0.0 to 2.5 V. This standard improves operations in conditions where a bus must be isolated from large stubs. The SSTL-2 standard specifies an input voltage range of $-0.3 \text{ V} \leq V_I \leq V_{CCIO} + 0.3 \text{ V}$. SSTL-2 requires a V_{REF} value of 1.25 V and a V_{TT} value of 1.25 V connected to the termination resistors (see Figures 10-1 and 10-2).

Figure 10-1. SSTL-2 Class I Termination

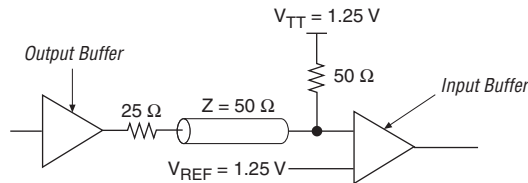
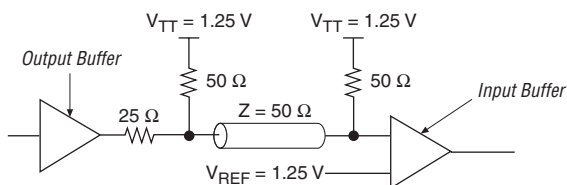

Figure 10–2. SSTL-2 Class II Termination

Cyclone II devices support both input and output SSTL-2 class I and II levels.

Pseudo-Differential SSTL-2

The differential SSTL-2 I/O standard (EIA/JEDEC standard JESD8-9A) is a 2.5-V standard used for applications such as high-speed DDR SDRAM clock interfaces. This standard supports differential signals in systems using the SSTL-2 standard and supplements the SSTL-2 standard for differential clocks. The differential SSTL-2 standard specifies an input voltage range of $-0.3 \text{ V} \leq V_I \leq V_{CCIO} + 0.3 \text{ V}$. The differential SSTL-2 standard does not require an input reference voltage. See [Figures 10–3](#) and [10–4](#) for details on differential SSTL-2 terminations.

Cyclone II devices do not support true differential SSTL-2 standards. Cyclone II devices support pseudo-differential SSTL-2 outputs for PLL_OUT pins and pseudo-differential SSTL-2 inputs for clock pins. Pseudo-differential inputs require an input reference voltage as opposed to the true differential inputs. See [Table 10–1 on page 10–2](#) for information about pseudo-differential SSTL.

Figure 10–3. SSTL-2 Class I Differential Termination

Figure 10–4. SSTL-2 Class II Differential Termination

1.8-V LVTTTL Normal & Wide Voltage Ranges (EIA/JEDEC Standard EIA/JESD8-7)

The 1.8-V I/O standard is used for 1.8-V LVTTTL applications. This standard defines the DC interface parameters for high-speed, low-voltage, non-terminated digital circuits driving or being driven by other 1.8-V parts. The input and output voltage ranges are:

- The 1.8-V normal and wide range input standards specify an input voltage range of $-0.3\text{ V} \leq V_I \leq 2.25\text{ V}$.
- The normal range minimum V_{OH} requirement is $V_{CCIO} - 0.45\text{ V}$.
- The wide range minimum V_{OH} requirement is $V_{CCIO} - 0.2\text{ V}$.

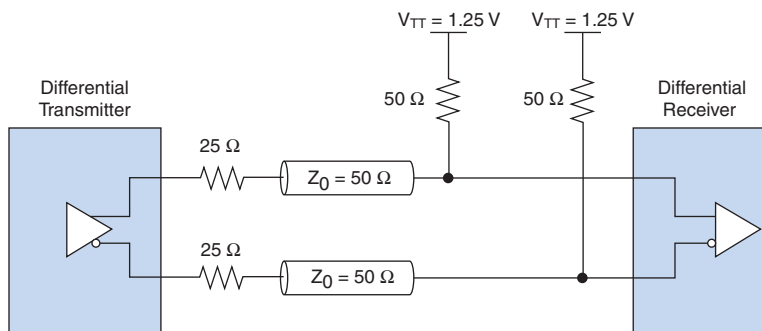
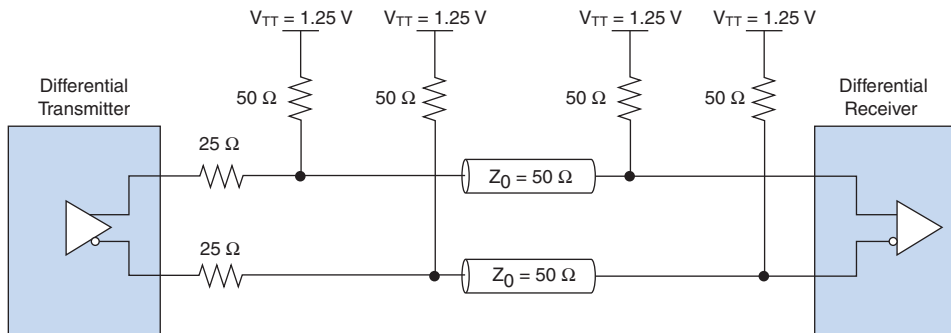
The 1.8-V standard does not require input reference voltages or board terminations. Cyclone II devices support input and output levels for both normal and wide 1.8-V LVTTTL ranges.

1.8-V LVCMOS Normal & Wide Voltage Ranges (EIA/JEDEC Standard EIA/JESD8-7)

The 1.8-V I/O standard is used for 1.8-V LVCMOS applications. This standard defines the DC interface parameters for high-speed, low-voltage, non-terminated digital circuits driving or being driven by other 1.8-V parts. The input and output voltage ranges are:

- The 1.8-V normal and wide range input standards specify an input voltage range of $-0.3\text{ V} \leq V_I \leq 2.25\text{ V}$.
- The normal range minimum V_{OH} requirement is $V_{CCIO} - 0.45\text{ V}$.
- The wide range minimum V_{OH} requirement is $V_{CCIO} - 0.2\text{ V}$.

The 1.8-V standard does not require input reference voltages or board terminations. Cyclone II devices support input and output levels for both normal and wide 1.8-V LVCMOS ranges.

SSTL-18 Class I & II

The 1.8-V SSTL-18 standard is formulated under JEDEC Standard, JESD815: Stub Series Terminated Logic for 1.8V (SSTL-18).

The SSTL-18 I/O standard is a 1.8-V memory bus standard used for applications such as high-speed DDR2 SDRAM interfaces. This standard is similar to SSTL-2 and defines input and output specifications for devices that are designed to operate in the SSTL-18 logic switching range 0.0 to 1.8 V. SSTL-18 requires a 0.9-V V_{REF} and a 0.9-V V_{TT} with the termination resistors connected to both. There are no class definitions for the SSTL-18 standard in the JEDEC specification. The specification of this I/O standard is based on an environment that consists of both series and parallel terminating resistors. Altera provides solutions to two derived applications in JEDEC specification and names them class I and class II to be consistent with other SSTL standards. Figures 10–5 and 10–6 show SSTL-18 class I and II termination, respectively. Cyclone II devices support both input and output levels.

Figure 10–5. 1.8-V SSTL Class I Termination

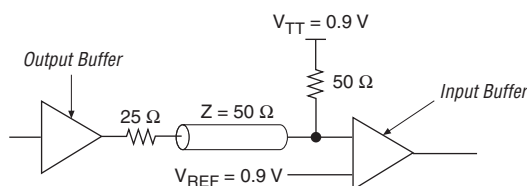
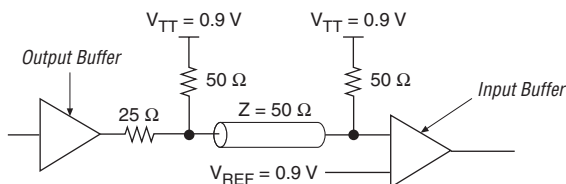

Figure 10–6. 1.8-V SSTL Class II Termination



1.8-V HSTL Class I & II

The HSTL standard is a technology independent I/O standard developed by JEDEC to provide voltage scalability. It is used for applications designed to operate in the 0.0- to 1.8-V HSTL logic switching range such as quad data rate (QDR) memory clock interfaces.

Although JEDEC specifies a maximum V_{CCIO} value of 1.6 V, there are various memory chip vendors with HSTL standards that require a V_{CCIO} of 1.8 V. Cyclone II devices support interfaces with V_{CCIO} of 1.8 V for HSTL. Figures 10-7 and 10-8 show the nominal V_{REF} and V_{TT} required to track the higher value of V_{CCIO} . The value of V_{REF} is selected to provide optimum noise margin in the system. Cyclone II devices support both input and output levels of operation.

Figure 10-7. 1.8-V HSTL Class I Termination

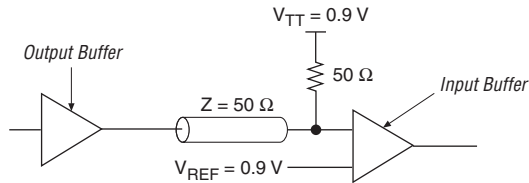
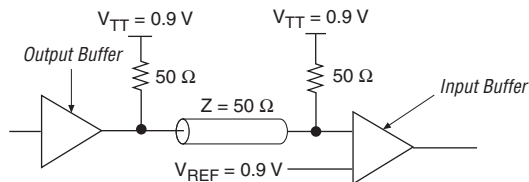

Figure 10-8. 1.8-V HSTL Class II Termination



Pseudo-Differential SSTL-18 Class I & Differential SSTL-18 Class II

The 1.8-V differential SSTL-18 standard is formulated under JEDEC Standard, JESD8-15: Stub Series Terminated Logic for 1.8V (SSTL-18).

The differential SSTL-18 I/O standard is a 1.8-V standard used for applications such as high-speed DDR2 SDRAM interfaces. This standard supports differential signals in systems using the SSTL-18 standard and supplements the SSTL-18 standard for differential clocks. See [Figures 10–9 and 10–10](#) for details on differential SSTL-18 termination.

Cyclone II devices do not support true differential SSTL-18 standards. Cyclone II devices support pseudo-differential SSTL-18 outputs for PLL_OUT pins and pseudo-differential SSTL-18 inputs for clock pins. Pseudo-differential inputs require an input reference voltage as opposed to the true differential inputs. See [Table 10–1 on page 10–2](#) for information about pseudo-differential SSTL.

Figure 10–9. Differential SSTL-18 Class I Termination

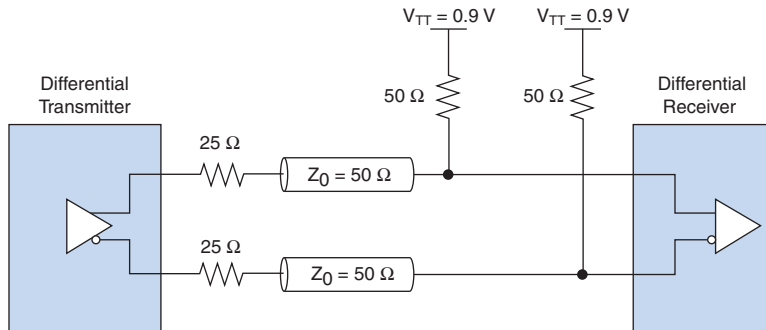
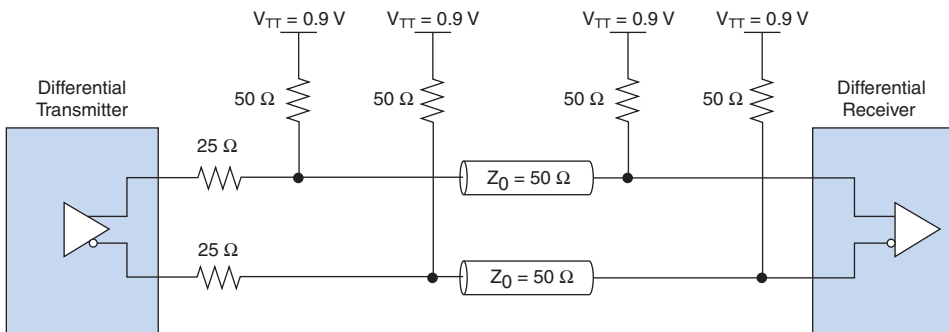

Figure 10–10. Differential SSTL-18 Class II Termination



1.8-V Pseudo-Differential HSTL Class I & II

The 1.8-V differential HSTL specification is the same as the 1.8-V single-ended HSTL specification. It is used for applications designed to operate in the 0.0 to 1.8-V HSTL logic switching range such as QDR memory clock interfaces. Cyclone II devices support both input and output levels. See [Figures 10–11 and 10–12](#) for details on 1.8-V differential HSTL termination.

Cyclone II devices do not support true 1.8-V differential HSTL standards. Cyclone II devices support pseudo-differential HSTL outputs for PLL_OUT pins and pseudo-differential HSTL inputs for clock pins. Pseudo-differential inputs require an input reference voltage as opposed to the true differential inputs. See [Table 10–1 on page 10–2](#) for information about pseudo-differential HSTL.

Figure 10–11. 1.8-V Differential HSTL Class I Termination

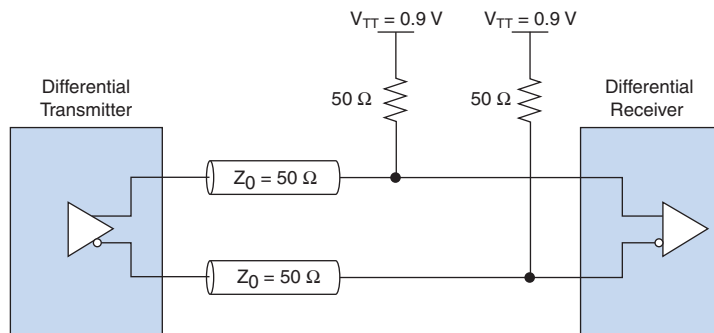
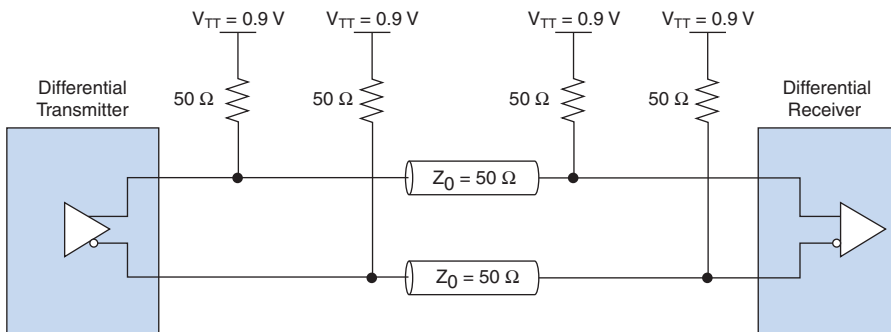

Figure 10–12. 1.8-V Differential HSTL Class II Termination



1.5-V LVC MOS Normal & Wide Voltage Ranges (EIA/JEDEC Standard JESD8-11)

The 1.5-V I/O standard is used for 1.5-V applications. This standard defines the DC interface parameters for high-speed, low-voltage, non-terminated digital circuits driving or being driven by other 1.5-V devices. The input and output voltage ranges are:

- The 1.5-V normal and wide range input standards specify an input voltage range of $-0.3 \text{ V} \leq V_I \leq 1.9 \text{ V}$.
- The normal range minimum V_{OH} requirement is 1.05 V.
- The wide range minimum V_{OH} requirement is $V_{CCIO} - 0.2 \text{ V}$.

The 1.5-V standard does not require input reference voltages or board terminations. Cyclone II devices support input and output levels for both normal and wide 1.5-V LVC MOS ranges.

1.5-V HSTL Class I & II

The 1.5-V HSTL standard is formulated under EIA/JEDEC Standard, EIA/JESD8-6: A 1.5V Output Buffer Supply Voltage Based Interface Standard for Digital Integrated Circuits.

The 1.5-V HSTL I/O standard is used for applications designed to operate in the 0.0- to 1.5-V HSTL logic nominal switching range. This standard defines single-ended input and output specifications for all HSTL-compliant digital integrated circuits. The 1.5-V HSTL I/O standard in Cyclone II devices is compatible with the 1.8-V HSTL I/O standard in APEX™ 20KE, APEX 20KC, Stratix® II, Stratix GX, Stratix, and in Cyclone II devices themselves because the input and output voltage thresholds are compatible. See Figures 10–13 and 10–14. Cyclone II devices support both input and output levels with V_{REF} and V_{TT} .

Figure 10–13. 1.5-V HSTL Class I Termination

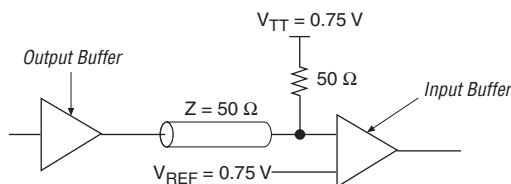
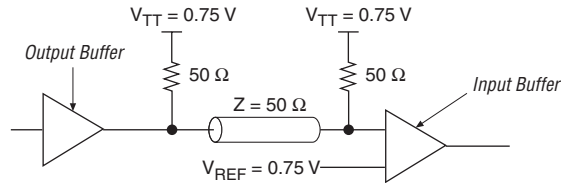

Figure 10–14. 1.5-V HSTL Class II Termination

1.5-V Pseudo-Differential HSTL Class I & II

The 1.5-V differential HSTL standard is formulated under EIA/JEDEC Standard, EIA/JESD8-6: A 1.5V Output Buffer Supply Voltage Based Interface Standard for Digital Integrated Circuits.

The 1.5-V differential HSTL specification is the same as the 1.5-V single-ended HSTL specification. It is used for applications designed to operate in the 0.0- to 1.5-V HSTL logic switching range, such as QDR memory clock interfaces. Cyclone II devices support both input and output levels. See [Figures 10–15 and 10–16](#) for details on the 1.5-V differential HSTL termination.

Cyclone II devices do not support true 1.5-V differential HSTL standards. Cyclone II devices support pseudo-differential HSTL outputs for PLL_OUT pins and pseudo-differential HSTL inputs for clock pins. Pseudo-differential inputs require an input reference voltage as opposed to the true differential inputs. See [Table 10–1 on page 10–2](#) for information about pseudo-differential HSTL.

Figure 10–15. 1.5-V Differential HSTL Class I Termination

Figure 10–16. 1.5-V Differential HSTL Class II Termination

LVDS, RSDS & mini-LVDS

The LVDS standard is formulated under ANSI/TIA/EIA Standard, ANSI/TIA/EIA-644: Electrical Characteristics of Low Voltage Differential Signaling Interface Circuits.

The LVDS I/O standard is a differential high-speed, low-voltage swing, low-power, general-purpose I/O interface standard. This standard is used in applications requiring high-bandwidth data transfer, backplane drivers, and clock distribution. The ANSI/TIA/EIA-644 standard specifies LVDS transmitters and receivers must be capable of operating at maximum data signaling rates of 655 megabits per second (Mbps). However, devices can operate at slower speeds if needed. Cyclone II devices are capable of running at a maximum data rate of 805 Mbps for input and 622 Mbps for output and still meet the ANSI/TIA/EIA-644 standard, with the following exceptions:

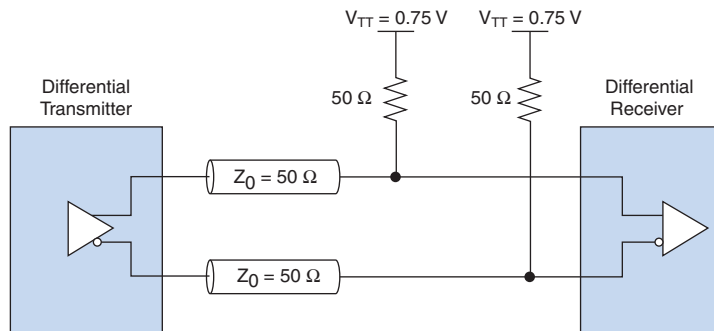
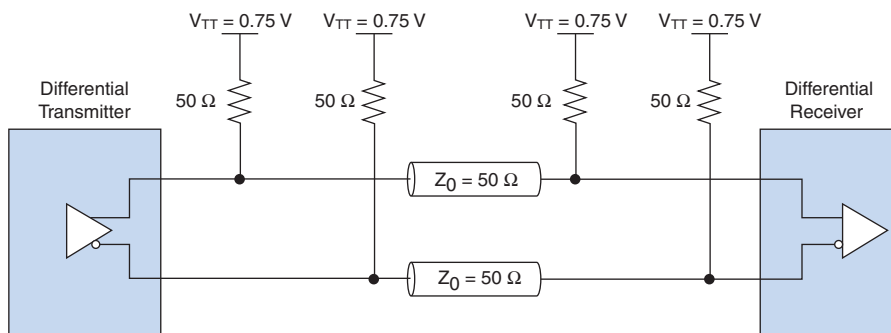
- The maximum differential output voltage (V_{OD}) is increased to 600 mV.
- The input voltage range is from 0 to 1.85 V for data rates less than 700 Mbps.
- The input voltage range is reduced to 1.0 to 1.6 V for data rates above 700 Mbps.

Because of the low voltage swing of the LVDS I/O standard, the electromagnetic interference (EMI) effects are much smaller than complementary metal-oxide semiconductor (CMOS), transistor-to-transistor logic (TTL), and positive (or pseudo) emitter coupled logic (PECL). This low EMI makes LVDS ideal for applications with low EMI requirements or noise immunity requirements. The LVDS standard does not require an input reference voltage. However, it does require a

termination resistor of 90 to 110 Ω between the two signals at the input buffer. Cyclone II devices support true differential LVDS inputs and outputs.



LVDS outputs on Cyclone II need external resistor network to work properly. See the *High Speed Differential Interfaces in Cyclone II Devices* chapter in Volume 1 of the *Cyclone II Device Handbook* for more information.

For reduced swing differential signaling (RSDS), V_{OD} ranges from 100 to 600 mV. For mini-LVDS, V_{OD} ranges from 300 to 600 mV. The differential termination resistor value ranges from 95 to 105 Ω for both RSDS and mini-LVDS. Cyclone II devices support RSDS/mini-LVDS outputs only.

Differential LVPECL

The low voltage positive (or pseudo) emitter coupled logic (LVPECL) standard is a differential interface standard requiring a 3.3-V V_{CCIO} . The standard is used in applications involving video graphics, telecommunications, data communications, and clock distribution. The high-speed, low-voltage swing LVPECL I/O standard uses a positive power supply and is similar to LVDS. However, LVPECL has a larger differential output voltage swing than LVDS. The LVPECL standard does not require an input reference voltage, but it does require an external 100- Ω termination resistor between the two signals at the input buffer. [Figures 10–17](#) and [10–18](#) show two alternate termination schemes for LVPECL. LVPECL input standard is supported at the clock input pins on Cyclone II devices. LVPECL output standard is not supported.

Figure 10–17. LVPECL DC Coupled Termination

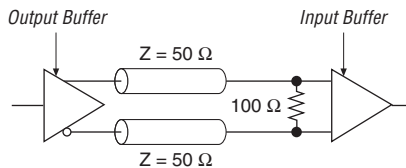
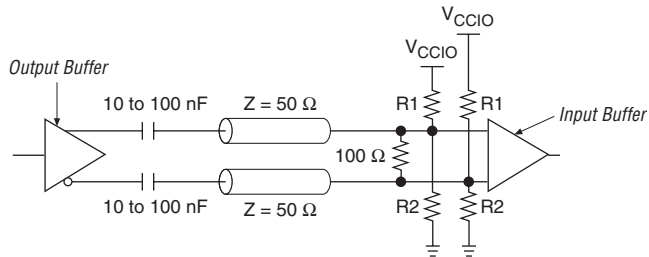

Figure 10–18. LVPECL AC Coupled Termination

Cyclone II I/O Banks

The I/O pins on Cyclone II devices are grouped together into I/O banks, and each bank has a separate power bus. This permits designers to select the preferred I/O standard for a given bank enabling tremendous flexibility in the Cyclone II device's I/O support.

EP2C5 and EP2C8 devices support four I/O banks. EP2C20, EP2C35, EP2C50, and EP2C70 devices support eight I/O banks. Each device I/O pin is associated with one of these specific, numbered I/O banks (see [Figures 10–19](#) and [10–20](#)). To accommodate voltage-referenced I/O standards, each Cyclone II I/O bank has separate V_{REF} bus. Each bank in EP2C5, EP2C8, EP2C20, EP2C35, and EP2C50 devices supports two V_{REF} pins and each bank in EP2C70 devices supports four V_{REF} pins. In the event these pins are not used as V_{REF} pins, they may be used as regular I/O pins. However, they are expected to have slightly higher pin capacitance than other user I/O pins when used with regular user I/O pins.

Figure 10–19. EP2C5 & EP2C8 Device I/O Banks Notes (1), (2)

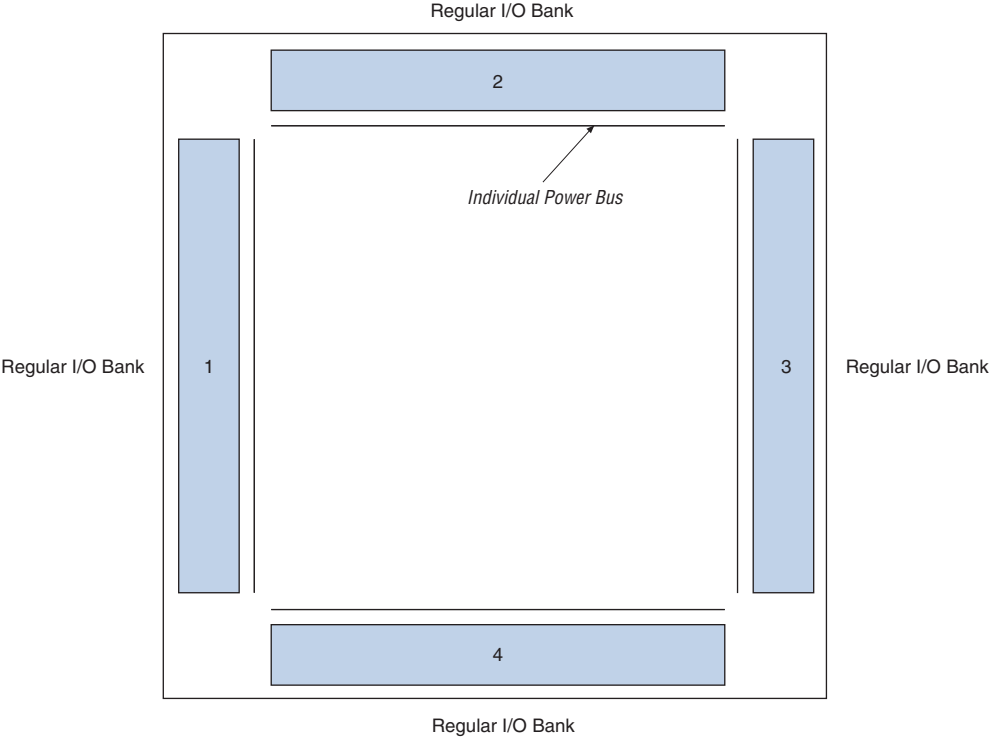

Notes to Figure 10–19:

- (1) This is a top view of the silicon die.
- (2) This is a graphic representation only. See the pin list and the Quartus II software for exact pin locations.

Figure 10–20. EP2C20, EP2C35, EP2C50 & EP2C70 Device I/O Banks Notes (1), (2)

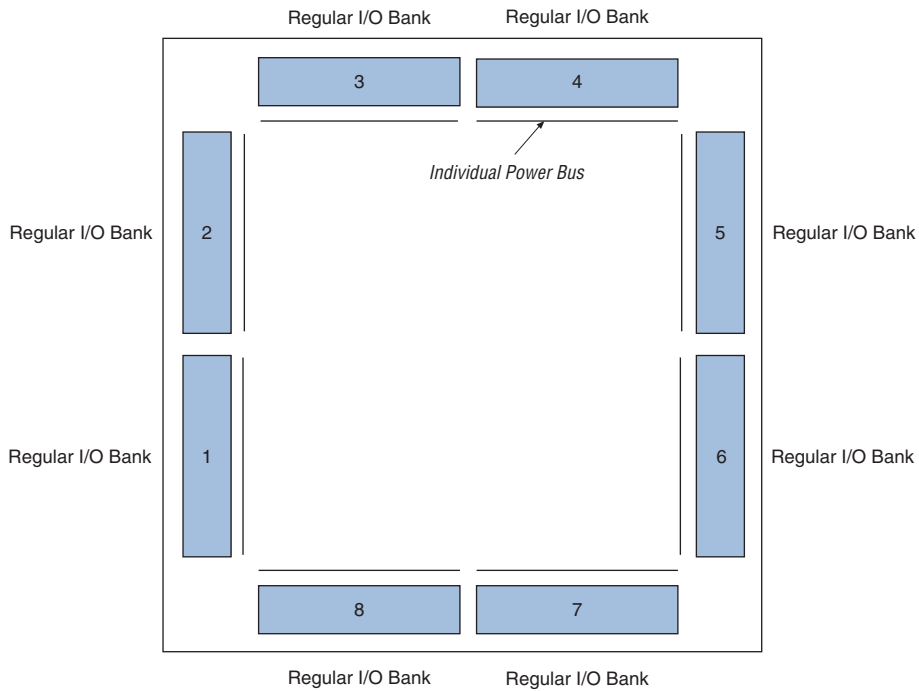

Notes to Figure 10–20:

- (1) This is a top view of the silicon die.
 - (2) This is a graphic representation only. See the pin list and the Quartus II software for exact pin locations.
-

Additionally, each Cyclone II I/O bank has its own V_{CCIO} pins. Any single I/O bank can only support one V_{CCIO} setting from among 1.5, 1.8, 2.5 or 3.3 V. Although there can only be one V_{CCIO} voltage per I/O bank, Cyclone II devices permit additional input signaling capabilities, as shown in [Table 10–4](#).

Table 10–4. Acceptable Input Levels for LVTTTL & LVCMOS

Bank V_{CCIO} (V)	Acceptable Input Levels (V)			
	3.3	2.5	1.8	1.5
3.3	✓	✓ (1)		
2.5	✓	✓		
1.8	✓ (2)	✓ (2)	✓	✓ (1)
1.5	✓ (2)	✓ (2)	✓	✓

Notes to Table 10–4:

- (1) Because the input level will not drive to the rail, the input buffer does not completely shut off, and the I/O current will be slightly higher than the default value.
- (2) These input values overdrive the input buffer, so the pin leakage current will be slightly higher than the default value.

Any number of supported single-ended or differential standards can be simultaneously supported in a single I/O bank as long as they use compatible V_{CCIO} levels for input and output pins. For example, an I/O bank with a 2.5-V V_{CCIO} setting can support 2.5-V LVTTTL inputs and outputs, 2.5-V LVDS-compatible inputs and outputs, and 3.3-V LVCMOS inputs only.

Voltage-referenced standards can be supported in an I/O bank using any number of single-ended or differential standards as long as they use the same V_{REF} and a compatible V_{CCIO} value. For example, if you choose to implement both SSTL-2 and SSTL-18 in your Cyclone II device, I/O pins using these standards—because they require different V_{REF} values—must be in different banks from each other. However, the same I/O bank can support SSTL-2 and 2.5-V LVCMOS with the V_{CCIO} set to 2.5 V and the V_{REF} set to 1.25 V.



See “[Pad Placement & DC Guidelines](#)” on page 10–26 for more information.

[Table 10–5](#) shows I/O standards supported when a pin is used as a regular I/O pin in the I/O banks of Cyclone II devices.

I/O Standard	I/O Banks for EP2C20, EP2C35, EP2C50 & EP2C70 Devices								I/O Banks for EP2C5 & EP2C8 Devices			
	1	2	3	4	5	6	7	8	1	2	3	4
LVTTTL	✓	✓	✓	✓	✓	✓	✓	✓	✓	✓	✓	✓
LVC MOS	✓	✓	✓	✓	✓	✓	✓	✓	✓	✓	✓	✓
2.5 V	✓	✓	✓	✓	✓	✓	✓	✓	✓	✓	✓	✓
1.8 V	✓	✓	✓	✓	✓	✓	✓	✓	✓	✓	✓	✓
1.5 V	✓	✓	✓	✓	✓	✓	✓	✓	✓	✓	✓	✓
3.3-V PCI	✓	✓			✓	✓			✓		✓	
3.3-V PCI-X	✓	✓			✓	✓			✓		✓	
SSTL-2 class I	✓	✓	✓	✓	✓	✓	✓	✓	✓	✓	✓	✓
SSTL-2 class II	✓	✓	✓	✓	✓	✓	✓	✓	✓	✓	✓	✓
SSTL-18 class I	✓	✓	✓	✓	✓	✓	✓	✓	✓	✓	✓	✓
SSTL-18 class II	(1)	(1)	✓	✓	(1)	(1)	✓	✓	(1)	✓	(1)	✓
1.8-V HSTL class I	✓	✓	✓	✓	✓	✓	✓	✓	✓	✓	✓	✓
1.8-V HSTL class II	(1)	(1)	✓	✓	(1)	(1)	✓	✓	(1)	✓	(1)	✓
1.5-V HSTL class I	✓	✓	✓	✓	✓	✓	✓	✓	✓	✓	✓	✓
1.5-V HSTL class II	(1)	(1)	✓	✓	(1)	(1)	✓	✓	(1)	✓	(1)	✓
Pseudo-differential SSTL-2	(2)	(2)	(2)	(2)	(2)	(2)	(2)	(2)	(2)	(2)	(2)	(2)
Pseudo-differential SSTL-18	(2)	(2)	(2)	(2)	(2)	(2)	(2)	(2)	(2)	(2)	(2)	(2)
1.8-V pseudo-differential HSTL	(2)	(2)	(2)	(2)	(2)	(2)	(2)	(2)	(2)	(2)	(2)	(2)
1.5-V pseudo-differential HSTL	(2)	(2)	(2)	(2)	(2)	(2)	(2)	(2)	(2)	(2)	(2)	(2)
LVDS	✓	✓	✓	✓	✓	✓	✓	✓	✓	✓	✓	✓
RSDS and mini-LVDS	(3)	(3)	(3)	(3)	(3)	(3)	(3)	(3)	(3)	(3)	(3)	(3)
Differential LVPECL	(4)	(4)	(4)	(4)	(4)	(4)	(4)	(4)	(4)	(4)	(4)	(4)

Notes to Table 10–5:

- (1) These I/O banks support SSTL-18 class II and 1.8- and 1.5-V HSTL class II inputs.
- (2) Pseudo-differential I/O standards are only supported for clock inputs and dedicated PLL_OUT outputs. See Table 10–1 for more information.
- (3) This I/O standard is only supported for outputs.
- (4) This I/O standard is only supported for the clock inputs.

Programmable Current Drive Strength

The Cyclone II device I/O standards support various output current drive settings as shown in Table 10–6. These programmable drive-strength settings are a valuable tool in helping decrease the effects of simultaneously switching outputs (SSO) in conjunction with reducing system noise. The supported settings ensure that the device driver meets the specifications for I_{OH} and I_{OL} of the corresponding I/O standard.

I/O Standard	I_{OH}/I_{OL} Current Strength Setting (mA)	
	Top & Bottom I/O Pins	Side I/O Pins
LVTTTL (3.3 V)	4	4
	8	8
	12	12
	16	16
	20	20
	24	24
LVCMOS (3.3 V)	4	4
	8	8
	12	12
	16	
	20	
	24	
LVTTTL and LVCMOS (2.5 V)	4	4
	8	8
	12	
	16	
LVTTTL and LVCMOS (1.8 V)	2	2
	4	4
	6	6
	8	8
	10	10
	12	12
LVCMOS (1.5 V)	2	2
	4	4
	6	6
	8	

Table 10–6. Programmable Drive Strength (Part 2 of 2)		
I/O Standard	I_{OH}/I_{OL} Current Strength Setting (mA)	
	Top & Bottom I/O Pins	Side I/O Pins
SSTL-2 class I	8	8
	12	12
SSTL-2 class II	16	16
	20	
	24	
SSTL-18 class I	4	4
	6	6
	8	8
	10	10
	12	
SSTL-18 class II	8	N/A
	16	
	18	
HSTL-18 class I	4	4
	6	6
	8	8
	10	10
	12	12
HSTL-18 class II	16	N/A
	18	
	20	
HSTL-15 class I	4	4
	6	6
	8	8
	10	
	12	
HSTL-15 class II	16	N/A

These drive-strength settings are programmable on a per-pin basis using the Quartus II software.

I/O Termination

The majority of the Cyclone II I/O standards are single-ended, non-voltage-referenced I/O standards and, as such, the following I/O standards do not specify a recommended termination scheme:

- 3.3-V LVTTTL and LVCMOS
- 2.5-V LVTTTL and LVCMOS
- 1.8-V LVTTTL and LVCMOS
- 1.5-V LVCMOS
- 3.3-V PCI and PCI-X

Voltage-Referenced I/O Standard Termination

Voltage-referenced I/O standards require both an input reference voltage, V_{REF} , and a termination voltage, V_{TT} . The reference voltage of the receiving device tracks the termination voltage of the transmitting device.



For more information on termination for voltage-referenced I/O standards, see [“Supported I/O Standards” on page 10–1](#).

Differential I/O Standard Termination

Differential I/O standards typically require a termination resistor between the two signals at the receiver. The termination resistor must match the differential load impedance of the bus.

Cyclone II devices support differential I/O standards LVDS, RSDS, and mini-LVDS, and differential LVPECL.



For more information on termination for differential I/O standards, see [“Supported I/O Standards” on page 10–1](#).

I/O Driver Impedance Matching (R_S) & Series Termination (R_S)

Cyclone II devices support driver impedance matching to the impedance of the transmission line, typically 25 or 50 Ω . When used with the output drivers, on-chip termination (OCT) sets the output driver impedance to 25 or 50 Ω by choosing the driver strength. Once matching impedance is selected, driver current can not be changed. Table 10-7 provides a list of output standards that support impedance matching.

Table 10-7. Selectable I/O Drivers with Impedance Matching & Series Termination

I/O Standard	Target R_S (Ω)
3.3-V LVTTTL/CMOS	25 (1)
2.5-V LVTTTL/CMOS	50 (1)
1.8-V LVTTTL/CMOS	50 (1)
SSTL-2 class I	50 (1)
SSTL-18 class I	50 (1)

Note to Table 10-7:

- (1) These R_S values are nominal values. Actual impedance will vary across process, voltage, and temperature conditions. Tolerance is pending characterization.

Pad Placement & DC Guidelines

This section provides pad placement guidelines for the programmable I/O standards supported by Cyclone II devices and includes essential information for designing systems using the devices' selectable I/O capabilities. This section also discusses the DC limitations and guidelines.

Quartus II software provides user controlled restriction relaxation options for some placement constraints. When a default restriction is relaxed by a user, the Quartus II fitter generates warnings.



For more information about how Quartus II software checks I/O restrictions, see the *I/O Assignment Planning & Analysis* chapter in the *Quartus II Handbook*.

Differential Pad Placement Guidelines

To maintain an acceptable noise level on the V_{CCIO} supply, there are restrictions on placement of single-ended I/O pads in relation to differential pads. Use the following guidelines for placing single-ended pads with respect to differential pads and for differential output pads placement in Cyclone II devices.

For the LVDS I/O standard:

- Single-ended inputs can be no closer than four pads away from an LVDS I/O pad.
- Single-ended outputs can be no closer than five pads away from an LVDS I/O pad.
- Maximum of four 155-MHz LVDS output channels per V_{CCIO} and ground pair.
- Maximum of three 311-MHz LVDS output channels per V_{CCIO} and ground pair.

The Quartus II software only checks the first two cases.

For the RSDS and mini-LVDS I/O standards:

- Single-ended inputs can be no closer than four pads away from an RSDS and mini-LVDS output pad.
- Single-ended outputs can be no closer than five pads away from an RSDS and mini-LVDS output pad.
- Maximum of three 85-MHz RSDS and mini-LVDS output channels per V_{CCIO} and ground pair.

The Quartus II software only checks the first two cases.

V_{REF} Pad Placement Guidelines

To maintain an acceptable noise level on the V_{CCIO} supply and to prevent output switching noise from shifting the V_{REF} rail, there are restrictions on the placement of single-ended voltage referenced I/Os with respect to V_{REF} pads and V_{CCIO} and ground pairs. Use the following guidelines for placing single-ended pads in Cyclone II devices.

The Quartus II software automatically does all the calculations in this section.

Input Pads

Each V_{REF} pad supports up to 15 input pads on each side of the V_{REF} pad for FineLine BGA devices. Each V_{REF} pad supports up to 10 input pads on each side of the V_{REF} pad for quad flat pack (QFP) devices. This is irrespective of V_{CCIO} and ground pairs, and is guaranteed by the Cyclone II architecture.

Output Pads

When a voltage referenced input or bidirectional pad does not exist in a bank, there is no limit to the number of output pads that can be implemented in that bank. When a voltage referenced input exists, each VCCIO and ground pair supports nine outputs for Fineline BGA packages or five outputs for QFP packages. Any non-SSTL and non-HSTL output can be no closer than two pads away from a V_{REF} pad to maintain acceptable noise levels. Any SSTL and HSTL output, except for pintable defined DQ and DQS outputs, can be no closer than two pads away from a V_{REF} pad.



See “[DDR & QDR Pads](#)” on page 10–31 for details about guidelines for DQ and DQS pads placement.

Bidirectional Pads

Bidirectional pads must satisfy input and output guidelines simultaneously.



See “[DDR & QDR Pads](#)” on page 10–31 for details about guidelines for DQ and DQS pads placement.

If the bidirectional pads are all controlled by the same output enable (OE) and there are no other outputs or voltage referenced inputs in the bank, then there is no case where there is a voltage referenced input is active at the same time as an output. Therefore, the output limitation does not apply. However, since the bidirectional pads are linked to the same OE, all the bidirectional pads will act as inputs at the same time. Therefore, the input limitation of 30 input pads (15 on each side of the V_{REF} pad) for FineLine BGA packages and 20 input pads (10 on each side of the V_{REF} pad) for QFP packages will apply.

If the bidirectional pads are all controlled by different OEs, and there are no other outputs or voltage referenced inputs in the bank, then there may be a case where one group of bidirectional pads is acting as inputs while another group is acting as outputs. In such cases, apply the formulas shown in [Table 10–8](#).

Table 10–8. Input-Only Bidirectional Pad Limitation Formulas	
Package Type	Formula
FineLine BGA	(Total number of bidirectional pads) – (Total number of pads from the smallest group of pads controlled by an OE) ≤ 9 (per VCCIO and ground pair)
QFP	(Total number of bidirectional pads) – (Total number of pads from the smallest group of pads controlled by an OE) ≤ 5 (per VCCIO and ground pair).

Consider a FineLine BGA package with four bidirectional pads controlled by the first OE, four bidirectional pads controlled by the second OE, and two bidirectional pads controlled by the third OE. If the first and second OEs are active and the third OE is inactive, there are 10 bidirectional pads, but it is safely allowable because there would be 8 or fewer outputs per VCCIO/GND pair.

When at least one additional voltage referenced input and no other outputs exist in the same V_{REF} bank, the bidirectional pad limitation applies in addition to the input and output limitations. See the following equations:

$$\text{Total number of bidirectional pads} + \text{total number of input pads} \leq 30$$

(15 on each side of your V_{REF} pad) for Fineline BGA packages

$$\text{Total number of bidirectional pads} + \text{total number of input pads} \leq 20$$

(10 on each side of your V_{REF} pad) for QFP packages

After applying the equation above, apply one of the equations in [Table 10–9](#), depending on the package type.

Table 10–9. Bidirectional Pad Limitation Formulas (Where V_{REF} Inputs Exist)	
Package Type	Formula
FineLine BGA	(Total number of bidirectional pads) ≤ 9 (per VCCIO and ground pair)
QFP	(Total number of bidirectional pads) ≤ 5 (per VCCIO and ground pair)

When at least one additional output exists but no voltage referenced inputs exist, apply the appropriate formula from [Table 10–10](#).

Table 10–10. Bidirectional Pad Limitation Formulas (Where V_{REF} Outputs Exist)	
Package Type	Formula
FineLine BGA	(Total number of bidirectional pads) + (Total number of additional output pads) – (Total number of pads from the smallest group of pads controlled by an OE) ≤ 9 (per V_{CCIO} and ground pair)
QFP	(Total number of bidirectional pads) + (Total number of additional output pads) – (Total number of pads from the smallest group of pads controlled by an OE) ≤ 5 (per V_{CCIO} and ground pair)

When additional voltage referenced inputs and other outputs exist in the same V_{REF} bank, the bidirectional pad limitation must again simultaneously adhere to the input and output limitations. As such, the following rules apply:

Total number of bidirectional pads + total number of input pads ≤ 30
(15 on each side of your V_{REF} pad) for FineLine BGA packages

Total number of bidirectional pads + total number of input pads ≤ 20
(10 on each side of your V_{REF} pad) for QFP packages

After applying the equation above, apply one of the equations in [Table 10–11](#), depending on the package type.

Table 10–11. Bidirectional Pad Limitation Formulas (Multiple V_{REF} Inputs & Outputs)	
Package Type	Formula
FineLine BGA	(Total number of bidirectional pads) + (Total number of output pads) ≤ 9 (per V_{CCIO}/GND pair)
QFP	Total number of bidirectional pads + Total number of output pads ≤ 5 (per V_{CCIO}/GND pair)

Each I/O bank can only be set to a single V_{CCIO} voltage level and a single V_{REF} voltage level at a given time. Pins of different I/O standards can share the bank if they have compatible V_{CCIO} values (see [Table 10–4](#) for more details) and compatible V_{REF} voltage levels.

DDR & QDR Pads

For dedicated DQ and DQS pads on a DDR interface, DQ pads have to be on the same power bank as DQS pads. With the DDR and DDR2 memory interfaces, a VCCIO and ground pair can have a maximum of five DQ pads.

For a QDR interface, D is the QDR output and Q is the QDR input. D pads and Q pads have to be on the same power bank as CQ. With the QDR and QDRII memory interfaces, a VCCIO and ground pair can have a maximum of five D and Q pads.

By default, the Quartus II software assigns D and Q pads as regular I/O pins. If you do not specify the function of a D or Q pad in the Quartus II software, the software will set them as regular I/O pins. If this occurs, Cyclone II QDR and QDRII performance is not guaranteed.

DC Guidelines

There is a current limit of 240 mA per eight consecutive output top and bottom pins per power pair, as shown by the following equation:

$$\sum_{pin}^{pin+7} I_{PIN} < 240\text{mA per power pair}$$

There is a current limit of 240 mA per 12 consecutive output side (left and right) pins per power pair, as shown by the following equation:

$$\sum_{pin}^{pin+11} I_{PIN} < 240\text{mA per power pair}$$

In all cases listed above, the Quartus II software generates an error message for illegally placed pads.

Table 10–12 shows the I/O standard DC current specification.

I/O Standard	I _{PIN} (mA)	
	Top & Bottom Banks	Side Banks
LVTTL	(1)	(1)
LVC MOS	(1)	(1)
2.5 V	(1)	(1)
1.8 V	(1)	(1)
1.5 V	(1)	(1)
3.3-V PCI	Not supported	1.5
3.3-V PCI-X	Not supported	1.5
SSTL-2 class I	12 (2)	12 (2)
SSTL-2 class II	24 (2)	20 (2)
SSTL-18 class I	12 (2)	12 (2)
SSTL-18 class II	8 (2)	Not supported
1.8-V HSTL class I	12 (2)	12 (2)
1.8-V HSTL class II	20 (2)	Not supported
1.5-V HSTL class I	12 (2)	10 (2)
1.5-V HSTL class II	18 (2)	Not supported
Differential SSTL-2 class I (3)	8.1 (4)	
Differential SSTL-2 class II (3)	16.4 (4)	
Differential SSTL-18 class I (3)	6.7 (4)	
Differential SSTL-18 class II (3)	13.4 (4)	
1.8-V differential HSTL class I (3)	8 (4)	
1.8-V differential HSTL class II (3)	16 (4)	
1.5-V differential HSTL class I (3)	8 (4)	

Table 10–12. Cyclone II I/O Standard DC Current Specification (Preliminary) (Part 2 of 2)

I/O Standard	I _{PIN} (mA)	
	Top & Bottom Banks	Side Banks
1.5-V differential HSTL class II (3)	16 (4)	
LVDS, RSDS and mini-LVDS	12	12

Notes to Table 10–12:

- (1) The DC power specification of each I/O standard depends on the current sourcing and sinking capabilities of the I/O buffer programmed with that standard, as well as the load being driven. LVTTTL and LVCMOS, and 2.5-, 1.8-, and 1.5-V outputs are not included in the static power calculations because they normally do not have resistor loads in real applications. The voltage swing is rail-to-rail with capacitive load only. There is no DC current in the system.
- (2) This I_{PIN} value represents the DC current specification for the default current strength of the I/O standard. The I_{PIN} varies with programmable drive strength and is the same as the drive strength as set in Quartus II software. See the *Cyclone II Architecture* chapter in Volume 1 of the *Cyclone II Device Handbook* for more information on the programmable drive strength feature of voltage referenced I/O standards.
- (3) The current value obtained for differential HSTL and differential SSTL standards is per pin and not per differential pair, as opposed to the per-pair current value of LVDS standard.
- (4) This I/O standard is only supported for clock input pins and PLL_OUT pins.

Table 10–12 only shows the limit on the static power consumed by an I/O standard. The amount of total power used at any moment could be much higher, and is based on the switching activities.

Conclusion

Cyclone II device I/O capabilities enable system designers to keep pace with increasing design complexity utilizing a low-cost FPGA device family. Support for I/O standards including SSTL and LVDS compatibility allow Cyclone II devices to fit into a wide variety of applications. The Quartus II software makes it easy to use these I/O standards in Cyclone II device designs. After design compilation, the software also provides clear, visual representations of pads and pins and the selected I/O standards. Taking advantage of the support of these I/O standards in Cyclone II devices will allow you to lower your design costs without compromising design flexibility or complexity.

More Information

For more information on Cyclone II devices, see the following resources:

- *Section I, Cyclone II Device Family Data Sheet of the Cyclone II Device Handbook*
- *AN 75: High-Speed Board Designs*

References

For more information on the I/O standards referred to in this document, see the following sources:

- Stub Series Terminated Logic for 2.5-V (SSTL-2), JESD8-9A, Electronic Industries Association, December 2000.
- 1.5-V +/- 0.1-V (Normal Range) and 0.9-V - 1.6-V (Wide Range) Power Supply Voltage and Interface Standard for Non-terminated Digital Integrated Circuits, JESD8-11, Electronic Industries Association, October 2000.
- 1.8-V +/- 0.15-V (Normal Range) and 1.2-V - 1.95-V (Wide Range) Power Supply Voltage and Interface Standard for Non-terminated Digital Integrated Circuits, JESD8-7, Electronic Industries Association, February 1997.
- 2.5-V +/- 0.2-V (Normal Range) and 1.8-V to 2.7-V (Wide Range) Power Supply Voltage and Interface Standard for Non-terminated Digital Integrated Circuits, JESD8-5, Electronic Industries Association, October 1995.
- Interface Standard for Nominal 3-V/ 3.3-V Supply Digital Integrated Circuits, JESD8-B, Electronic Industries Association, September 1999.
- PCI Local Bus Specification, Revision 2.2, PCI Special Interest Group, December 1998.
- Electrical Characteristics of Low Voltage Differential Signaling (LVDS) Interface Circuits, ANSI/TIA/EIA-644, American National Standards Institute/Telecommunications Industry/Electronic Industries Association, October 1995.

Introduction

From high-speed backplane applications to high-end switch boxes, low-voltage differential signaling (LVDS) is the technology of choice. LVDS is a low-voltage differential signaling standard, allowing higher noise immunity than single-ended I/O technologies. Its low-voltage swing allows for high-speed data transfers, low power consumption, and reduced electromagnetic interference (EMI). LVDS I/O signaling is a data interface standard defined in the TIA/EIA-644 and IEEE Std. 1596.3 specifications.

The reduced swing differential signaling (RSDS) and mini-LVDS standards are derivatives of the LVDS standard. The RSDS and mini-LVDS I/O standards are similar in electrical characteristics to LVDS, but have a smaller voltage swing and therefore provide increased power benefits and reduced EMI. National Semiconductor Corporation and Texas Instruments introduced the RSDS and mini-LVDS specifications, respectively. Currently many designers use these specifications for flat panel display links between the controller and the drivers that drive display column drivers. Cyclone™ II devices support the RSDS and mini-LVDS I/O standards at speeds up to 170 megabits per second (Mbps) at the transmitter. For RSDS and mini-LVDS, the maximum internal clock frequency is 85 MHz.

Altera® Cyclone II devices can transmit and receive data through LVDS signals at a data rate of up to 622 Mbps and 805 Mbps, respectively. For the LVDS transmitter and receiver, the Cyclone II device's input and output pins support serialization and deserialization through internal logic.

This chapter describes how to use Cyclone II I/O pins for differential signaling and contains the following topics:

- Cyclone II high-speed I/O banks
- Cyclone II high-speed I/O interface
- LVDS, RSDS, mini-LVDS, LVPECL, differential HSTL, and differential SSTL I/O standards support in Cyclone II devices
- High-speed I/O timing in Cyclone II devices
- Design guidelines

Cyclone II High-Speed I/O Banks

Cyclone II device I/O banks are shown in Figures 11–1 and 11–2. The EP2C5 and EP2C8 devices offer four I/O banks and EP2C20, EP2C35, EP2C50, and EP2C70 devices offer eight I/O banks. A subset of pins in each I/O bank (on both rows and columns) support the high-speed I/O interface. Cyclone II pin tables list the pins that support the high-speed I/O interface.

Figure 11–1. I/O Banks in EP2C5 & EP2C8 Devices

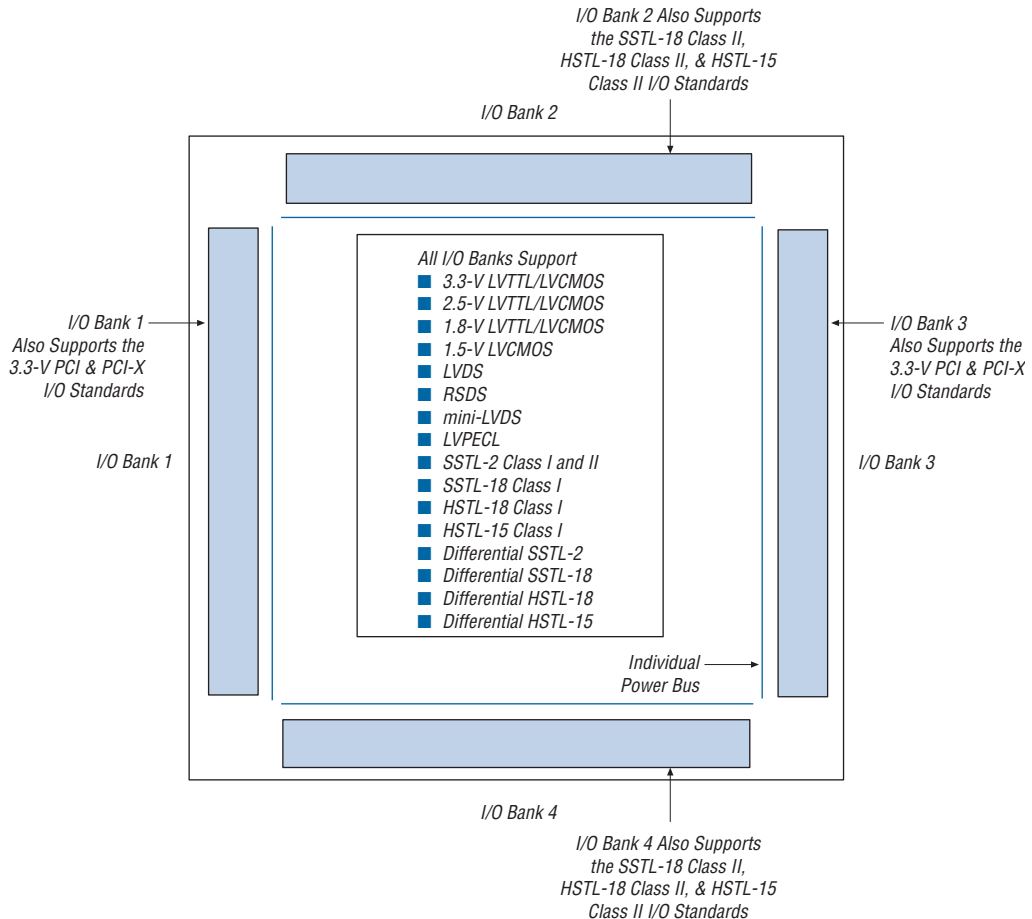
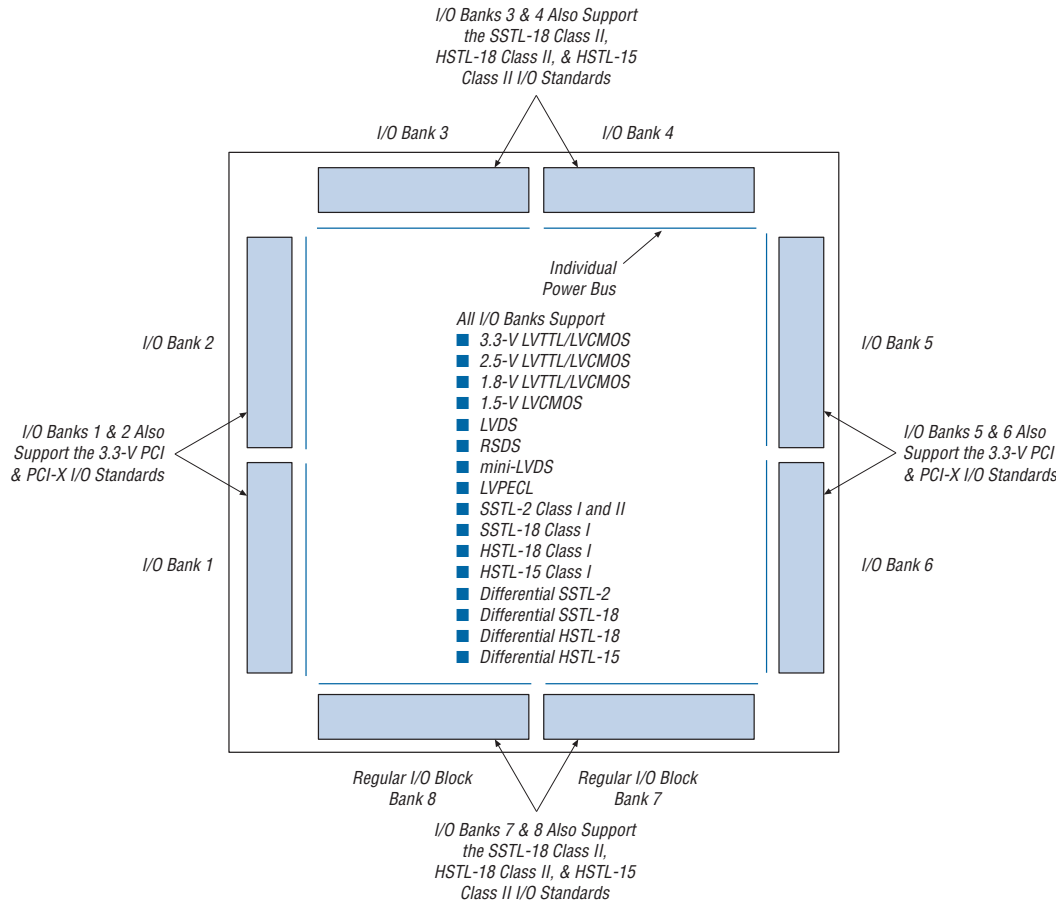

Figure 11–2. I/O Banks in EP2C20, EP2C35, EP2C50 & EP2C70 Devices



Cyclone II High-Speed I/O Interface

Cyclone II devices provide a multi-protocol interface that allows communication between a variety of I/O standards, including LVDS, LVPECL, RSDS, mini-LVDS, differential HSTL, and differential SSTL. This feature makes the Cyclone II device family ideal for applications that require multiple I/O standards, such as protocol translation.

You can use I/O pins and internal logic to implement a high-speed I/O receiver and transmitter in Cyclone II devices. Cyclone II devices do not contain dedicated serialization or deserialization circuitry. Therefore, shift registers, internal global phase-locked loops (PLLs), and I/O cells are used to perform serial-to-parallel conversions on incoming data and parallel-to-serial conversion on outgoing data.

I/O Standards Support

This section provides information on the I/O standards that Cyclone II devices support.

LVDS Standard Support in Cyclone II Devices

The LVDS I/O standard is a high-speed, low-voltage swing, low power, and general purpose I/O interface standard. The Cyclone II device meets the ANSI/TIA/EIA-644 standard, with the following exceptions:

- The maximum V_{OD} is increased to 600 mV.
- The input voltage range is reduced to a minimum of 0.5 V and a maximum of 1.85 V for data rates less than 700 Mbps. The input voltage range is reduced to a minimum of 1.0 V and a maximum of 1.6 V for data rates above 700 Mbps.

I/O banks on all four sides of the Cyclone II device support LVDS channels. See the pin tables on the Altera web site for the number of LVDS channels supported throughout different family members. Cyclone II LVDS receivers (input) support a data rate of up to 805 Mbps while LVDS transmitters (output) support up to 622 Mbps. The maximum internal clock frequency for a receiver is 402.5 MHz. The maximum clock frequency for a transmitter is 311 MHz. The maximum data rate of 805 Mbps is only achieved when DDIO registers are used. The LVDS standard does not require an input reference voltage; however, it does require a 100- Ω termination resistor between the two signals at the input buffer. [Table 11-1](#) shows LVDS I/O specifications.

Table 11-1. LVDS I/O Specifications (Part 1 of 2)

Symbol	Parameter	Condition	Min	Typ	Max	Units
V_{CCINT}	Supply voltage		1.15	1.2	1.25	V
V_{CCIO}	I/O supply voltage		2.375	2.5	2.625	V
V_{OD}	Differential output voltage	$R_L = 100 \Omega$	247		600	mv
ΔV_{OD}	Change in V_{OD} between H and L	$R_L = 100 \Omega$			50	mv
V_{OS}	Output offset voltage	$R_L = 100 \Omega$	1.125	1.25	1.375	V

Table 11–1. LVDS I/O Specifications (Part 2 of 2)

Symbol	Parameter	Condition	Min	Typ	Max	Units
ΔV_{OS}	Change in V_{OS} between H and L	$R_L = 100 \Omega$			50	mv
V_{IN}	Receiver input voltage range	Data rate ≤ 700 Mbps	0.5		1.85	V
		Data rate > 700 Mbps	1.0		1.6	V
R_L	Receiver differential input resistor		90	100	110	Ω

LVDS Receiver & Transmitter

Figure 11–3 shows a simple point-to-point LVDS application where the source of the data is an LVDS transmitter. These LVDS signals are typically transmitted over a pair of printed circuit board (PCB) traces, but a combination of a PCB trace, connectors, and cables is a common application setup.

Figure 11–3. Typical LVDS Application

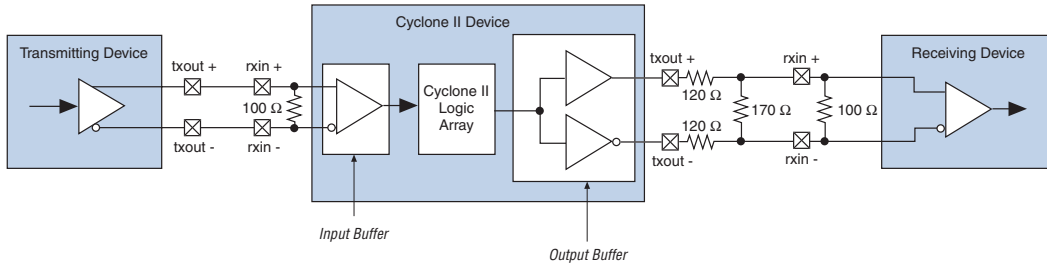

Figures 11–4 and 11–5 show the signaling levels for LVDS receiver inputs and transmitter outputs, respectively.

Figure 11–4. Receiver Input Waveforms for the LVDS Differential I/O Standard

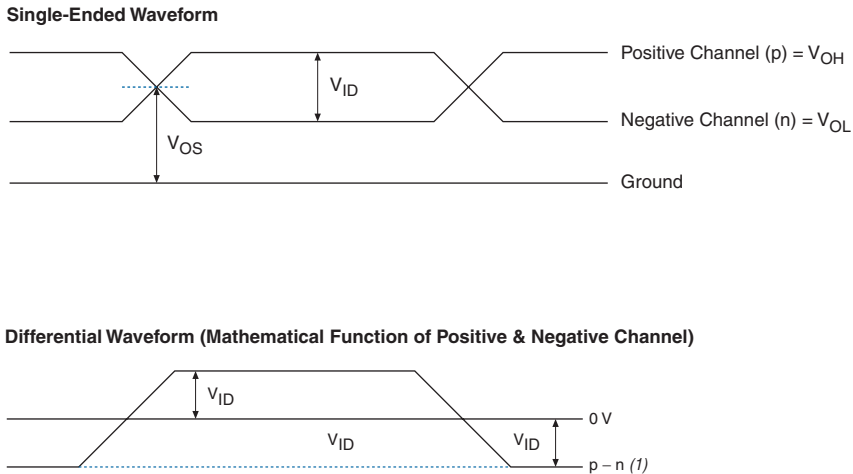

Note to Figure 11–4:

- (1) The $p - n$ waveform is a function of the positive channel (p) and the negative channel (n).

Figure 11–5. Transmitter Output Waveform for the LVDS Differential I/O Standard

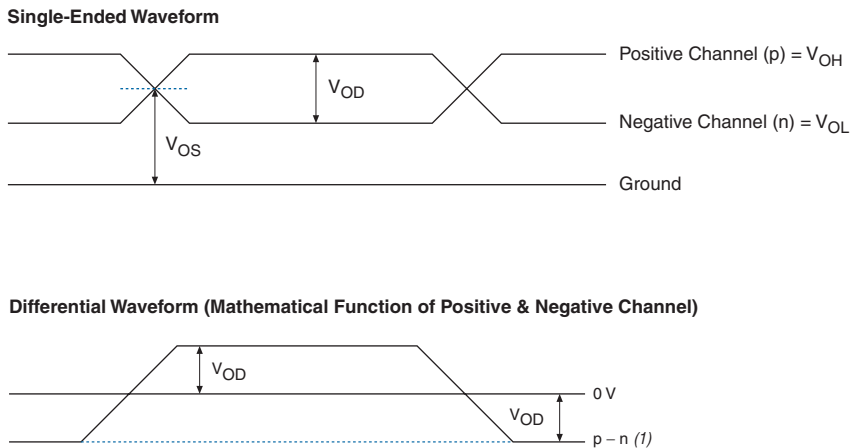

Note to Figure 11–5:

- (1) The $p - n$ waveform is a function of the positive channel (p) and the negative channel (n).

RSDS I/O Standard Support in Cyclone II Devices

The RSDS specification is used in chip-to-chip applications between the timing controller and the column drivers on display panels. Cyclone II devices meet the National Semiconductor Corporation RSDS Interface Specification and support the RSDS output standard. Table 11-2 shows the RSDS electrical characteristics for Cyclone II devices.

Symbol	Parameter	Condition	Min	Typ	Max	Unit
V_{CCIO}	Output supply voltage		2.375	2.5	2.625	V
V_{OD} (1)	Differential output voltage	$R_L = 100 \Omega$	100	200	600	mv
V_{OS} (2)	Output offset voltage	$R_L = 100 \Omega$	0.5	1.2	1.5	V
T_r/T_f	Transition time	$C_{load} = 5 \text{ pF}$		500		ps

Notes to Table 11-2:

- (1) $V_{OD} = V_{OH} - V_{OL}$.
 (2) $V_{OS} = (V_{OH} + V_{OL}) / 2$.

Figure 11-6 shows the RSDS transmitter output signal waveforms.

Figure 11-6. Transmitter Output Signal Level Waveforms for RSDS

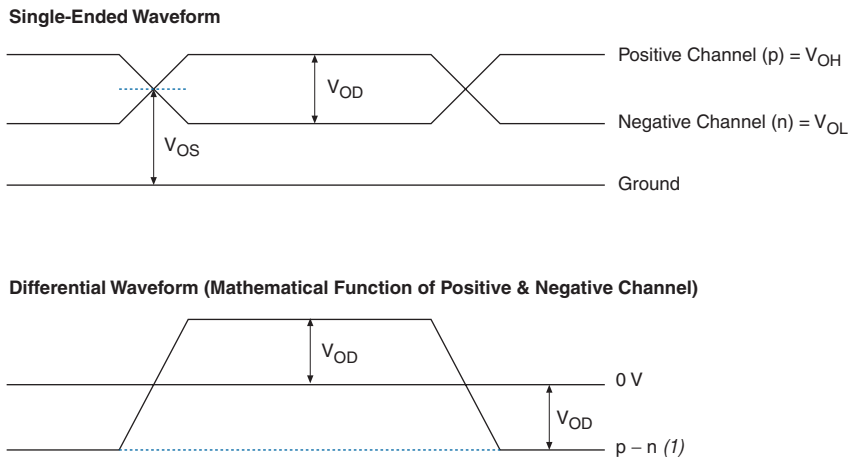

Note to Figure 11-6:

- (1) The $p - n$ waveform is a function of the positive channel (p) and the negative channel (n).

Designing with RSDS

Cyclone II devices support the RSDS output standard using the LVDS I/O buffer types. For transmitters, the LVDS output buffer can be used with the external resistor network shown in Figure 11-7.

Figure 11-7. RSDS Resistor Network Note (1)

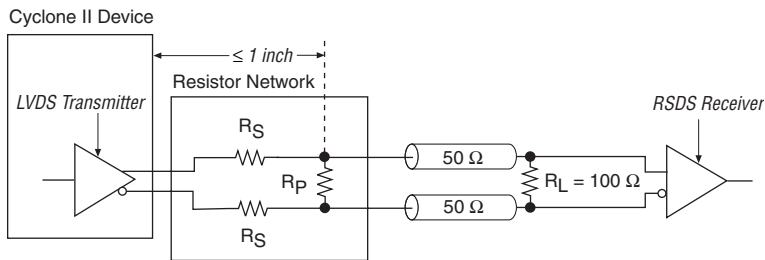

Note to Figure 11-7:

(1) Actual R_S and R_P values are pending on device characterization.



For more information on the RSDS I/O standard, see the RSDS specification from the National Semiconductor web site (www.national.com).

A resistor network is required to attenuate the LVDS output voltage swing to meet the RSDS specifications. The resistor network values can be modified to reduce power or improve the noise margin. The resistor values chosen should satisfy the following equation:

$$\frac{R_S \times \frac{R_P}{2}}{R_S + \frac{R_P}{2}} = 50 \Omega$$

Additional simulations using the IBIS models should be performed to validate that custom resistor values meet the RSDS requirements.

RSDS Software Support

When designing for the RSDS I/O standard, assign the LVDS I/O standard to the I/O pins intended for RSDS in the Quartus® II software. Contact Altera Applications for reference designs.

mini-LVDS Standard Support in Cyclone II Devices

The mini-LVDS specification defines its use in chip-to-chip applications between the timing controller and the column drivers on display panels. Cyclone II devices meet the Texas Instruments mini-LVDS Interface Specification and support the mini-LVDS output standard. Table 11-3 shows the mini-LVDS electrical characteristics for Cyclone II devices.

Table 11-3. mini-LVDS Electrical Characteristics for Cyclone II Devices

Symbol	Parameters	Condition	Min	Typ	Max	Units
V_{CCIO}	Output supply voltage		2.375	2.5	2.625	V
V_{OD} (1)	Differential output voltage	$R_L = 100 \Omega$	300		600	mV
V_{OS} (2)	Output offset voltage	$R_L = 100 \Omega$	1	1.2	1.4	mV
T_r / T_f	Transition time	20 to 80%			500	ps

Notes to Table 11-3:

- (1) $V_{OD} = V_{OH} - V_{OL}$.
- (2) $V_{OS} = (V_{OH} + V_{OL}) / 2$.

Figure 11-8 shows the mini-LVDS receiver and transmitter signal waveforms.

Figure 11-8. Transmitter Output Signal Level Waveforms for mini-LVDS

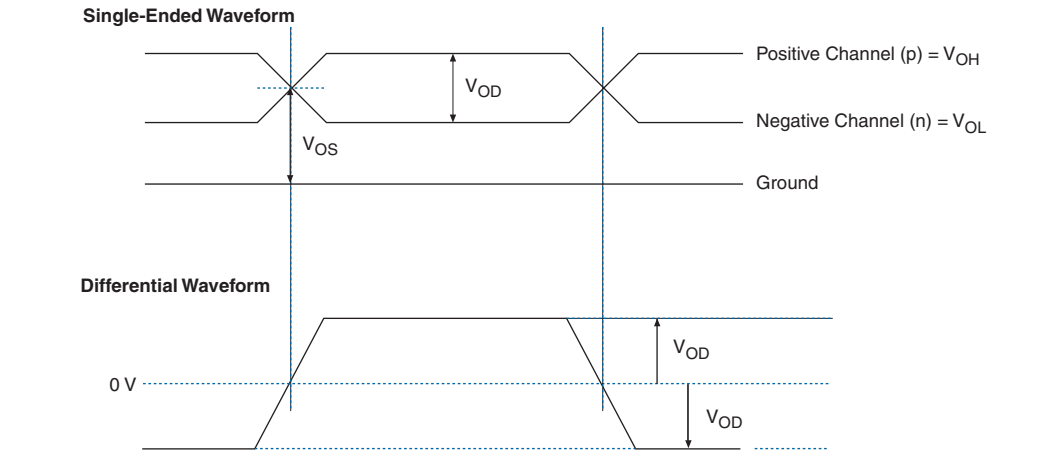

Designing with mini-LVDS

Similar to RSDS, Cyclone II devices support the mini-LVDS output standard using the LVDS I/O buffer types. For transmitters, the LVDS output buffer can be used with the external resistor network shown in [Figure 11-9](#). The resistor values chosen should satisfy the equation on page 11-8.

Figure 11-9. mini-LVDS Resistor Network

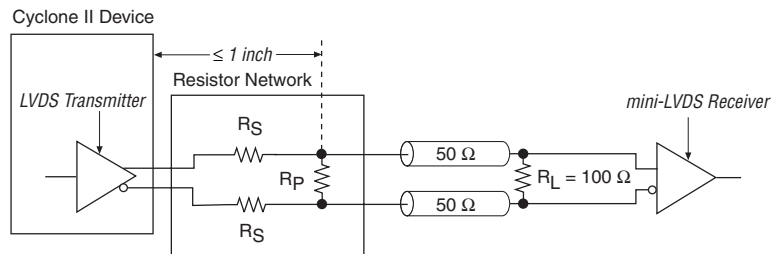

Note to Figure 11-9:

- (1) R_S and R_P values are pending on silicon characterization.

mini-LVDS Software Support

When designing for the mini-LVDS I/O standard, assign the LVDS I/O standard to the I/O pins intended for mini-LVDS in the Quartus II software. Contact Altera Applications for reference designs.

LVPECL Support in Cyclone II

The LVPECL I/O standard is a differential interface standard requiring a 3.3-V V_{CCIO} and is used in applications involving video graphics, telecommunications, data communications, and clock distribution. The high-speed, low-voltage swing LVPECL I/O standard uses a positive power supply and is similar to LVDS. However, LVPECL has a larger differential output voltage swing than LVDS. Cyclone II devices support the LVPECL input standard at the clock input pins only. Table 11-4 shows the LVPECL electrical characteristics for Cyclone II devices. Figure 11-10 shows the LVPECL I/O interface.

Symbol	Parameters	Condition	Min	Typ	Max	Units
V_{CCIO}	Output supply voltage		3.135	3.3	3.465	V
V_{IH}	Input high voltage		2,100		2,880	mV
V_{IL}	Input low voltage		0		2,200	mV
V_{ID}	Differential input voltage	Peak to peak	100	600	950	mV

Figure 11-10. LVPECL I/O Interface

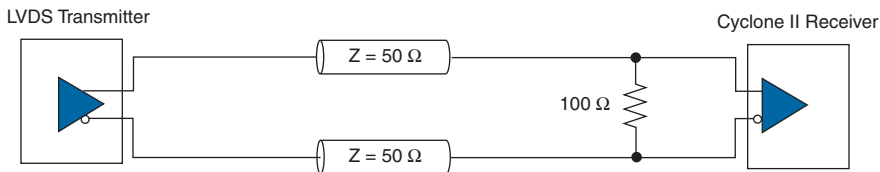

Differential SSTL Support in Cyclone II Devices

The differential SSTL I/O standard is a memory bus standard used for applications such as high-speed double data rate (DDR) SDRAM interfaces. The differential SSTL I/O standard is similar to voltage referenced SSTL and requires two differential inputs with an external termination voltage (V_{TT}) of $0.5 \times V_{CCIO}$ to which termination resistors are connected. A 2.5-V output source voltage is required for differential SSTL-2, while a 1.8-V output source voltage is required for differential SSTL-18. The differential SSTL output standard is only supported at PLLCLKOUT pins using two single-ended SSTL output buffers programmed to have opposite polarity.

The differential SSTL input standard is supported at the global clock (GCLK) pins only, treating differential inputs as two single-ended SSTL, and only decoding one of them.



For SSTL signaling characteristics, see the *DC Characteristics & Timing Specification* chapter and the *Selectable I/O Standards in Cyclone II Devices* chapter in Volume 1 of the *Cyclone II Device Handbook*.

Figures 11–11 and 11–12 show the differential SSTL class I and II interfaces, respectively.

Figure 11–11. Differential SSTL Class I Interface

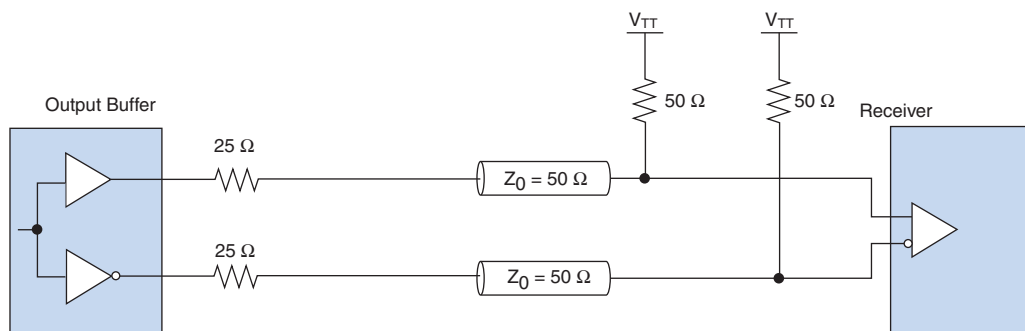
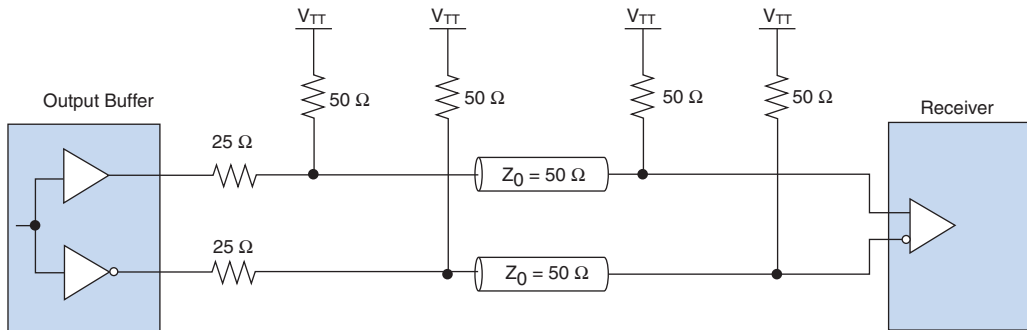

Figure 11–12. Differential SSTL Class II Interface

Differential HSTL Support in Cyclone II Devices

The differential HSTL AC and DC specifications are the same as the HSTL single-ended specifications. The differential HSTL I/O standard is available on the GCLK pins only, treating differential inputs as two single-ended HSTL, and only decoding one of them. The differential HSTL output I/O standard is only supported at the PLLCLKOUT pins using two single-ended HSTL output buffers with the second output programmed as inverted. The standard requires two differential inputs with an external termination voltage (V_{TT}) of $0.5 \times V_{CCIO}$ to which termination resistors are connected.



For the HSTL signaling characteristics, see the *DC Characteristics & Timing Specifications* chapter and the *Selectable I/O Standards in Cyclone II Devices* chapter in Volume 1 of the *Cyclone II Device Handbook*.

Figures 11–13 and 11–14 show differential HSTL class I and II interfaces, respectively.

Figure 11–13. Differential HSTL Class I Interface

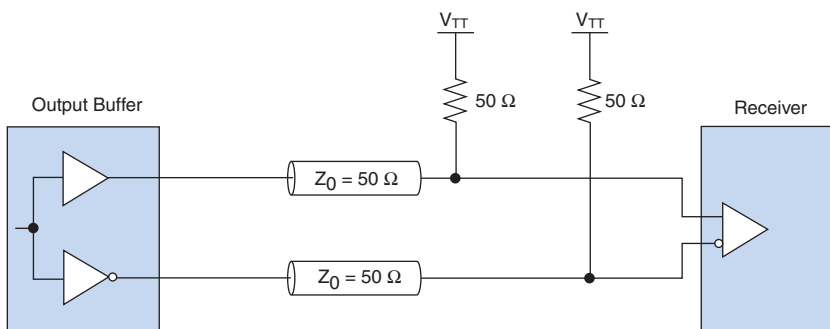
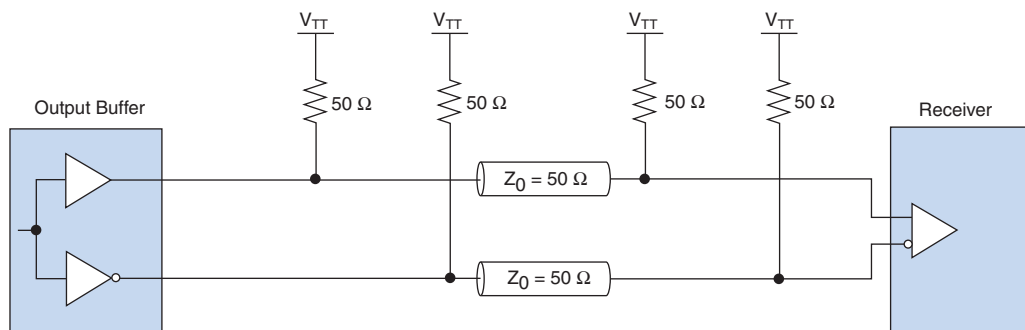

Figure 11–14. Differential HSTL Class II Interface



High-Speed I/O Timing in Cyclone II Devices

This section discusses the timing budget, waveforms, and specifications for source-synchronous signaling in Cyclone II devices. LVDS, LVPECL, RSDS, and mini-LVDS I/O standards enable high-speed data transmission. Timing for these high-speed signals is based on skew between the data and the clock signals.

High-speed differential data transmission requires timing parameters provided by integrated circuit (IC) vendors and requires consideration of board skew, cable skew, and clock jitter. This section provides details on high-speed I/O standards timing parameters in Cyclone II devices.

Table 11-5 defines the parameters of the timing diagram shown in Figure 11-15. Figure 11-16 shows the Cyclone II high-speed I/O timing budget.

Table 11-5. High-Speed I/O Timing Definitions		
Parameter	Symbol	Description
Transmitter channel-to-channel skew	TCCS	The timing difference between the fastest and slowest output edges, including t_{CO} variation and clock skew. The clock is included in the TCCS measurement.
Sampling window	SW	The period of time during which the data must be valid in order for you to capture it correctly. The setup and hold times determine the ideal strobe position within the sampling window. $T_{SW} = T_{SU} + T_{hd} + \text{PLL jitter}$.
Receiver input skew margin	RSKM	RSKM is defined by the total margin left after accounting for the sampling window and TCCS. The RSKM equation is: $RSKM = (TUI - SW - TCCS) / 2$.
Input jitter tolerance (peak-to-peak)		Allowed input jitter on the input clock to the PLL that is tolerable while maintaining PLL lock.
Output jitter (peak-to-peak)		Peak-to-peak output jitter from the PLL.

Figure 11-15. High-Speed I/O Timing Diagram

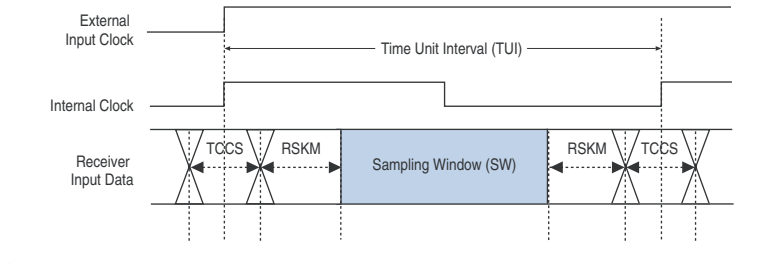
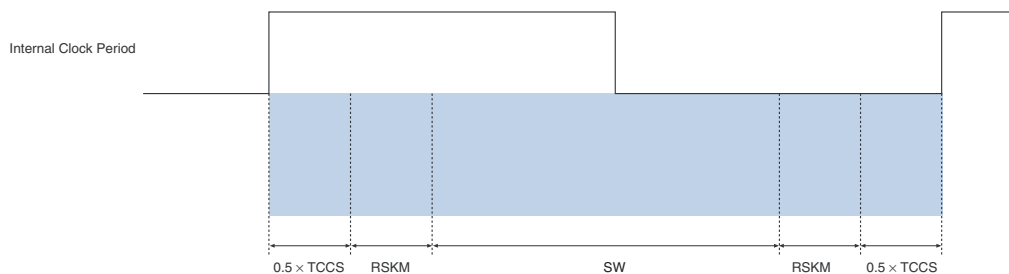

Figure 11–16. Cyclone II High-Speed I/O Timing Budget *Note (1)*



Note to Figure 11–16:

(1) The equation for the high-speed I/O timing budget is: $\text{Period} = 0.5/TCCS + RSKM + SW + RSKM + 0.5/TCCS$.

Design Guidelines

This section provides guidelines for designing with Cyclone II devices.

Differential Pad Placement Guidelines

To maintain an acceptable noise level on the V_{CCIO} supply, there are restrictions on placement of single-ended I/O pins in relation to differential pads.



See the guidelines in the *Selectable I/O Standards in Cyclone II Devices* chapter in Volume 1 of the *Cyclone II Device Handbook* for placing single-ended pads with respect to differential pads in Cyclone II devices.

Board Design Considerations

This section explains how to get the optimal performance from the Cyclone II I/O interface and ensure first-time success in implementing a functional design with optimal signal quality. The critical issues of controlled impedance of traces and connectors, differential routing, and termination techniques must be considered to get the best performance from the IC. The Cyclone II device generates signals that travel over the media at frequencies as high as 805 Mbps. Use the following general guidelines for improved signal quality:

- Base board designs on controlled differential impedance. Calculate and compare all parameters such as trace width, trace thickness, and the distance between two differential traces.

- Maintain equal distance between traces in LVDS pairs, as much as possible. Routing the pair of traces close to each other will maximize the common-mode rejection ratio (CMRR).
- Longer traces have more inductance and capacitance. These traces should be as short as possible to limit signal integrity issues.
- Place termination resistors as close to receiver input pins as possible.
- Use surface mount components.
- Avoid 90° or 45° corners.
- Use high-performance connectors.
- Design backplane and card traces so that trace impedance matches the connector's and/or the termination's impedance.
- Keep equal number of vias for both signal traces.
- Create equal trace lengths to avoid skew between signals. Unequal trace lengths result in misplaced crossing points and decrease system margins as the channel-to-channel skew (TCCS) value increases.
- Limit vias because they cause discontinuities.
- Use the common bypass capacitor values such as 0.001, 0.01, and 0.1 μF to decouple the high-speed PLL power and ground planes.
- Keep switching transistor-to-transistor logic (TTL) signals away from differential signals to avoid possible noise coupling.
- Do not route TTL clock signals to areas under or above the differential signals.
- Analyze system-level signals.

For PCB layout guidelines, see *AN 224: High-Speed Board Layout Guidelines*.

Conclusion

Cyclone II differential I/O capabilities enable you to keep pace with increasing design complexity. Support for I/O standards including LVDS, LVPECL, RSDS, mini-LVDS, differential SSTL and differential HSTL allows Cyclone II devices to fit into a wide variety of applications. Taking advantage of these I/O capabilities and Cyclone II pricing allows you to lower your design costs while remaining on the cutting edge of technology.

This section provides information for design and optimization of digital signal processing (DSP) functions and arithmetic operations using the embedded multiplier blocks.

This section includes the following chapter:

- [Chapter 12, Embedded Multipliers in Cyclone II Devices](#)

Revision History

The table below shows the revision history for [Chapter 12](#).

Chapter(s)	Date / Version	Changes Made
12	June 2004, v1.0	Added document to the Cyclone II Device Handbook.

Introduction

Cyclone™ II devices have embedded multiplier blocks optimized for multiplier-intensive low-cost digital signal processing (DSP) applications. These embedded multipliers combined with the flexibility of programmable logic devices (PLDs), provide designers with the ability to efficiently implement various cost sensitive DSP functions easily. Consumer-based application systems such as digital television (DTV) and home entertainment systems typically require a cost effective solution for implementing multipliers to perform signal processing functions like finite impulse response (FIR) filters, fast Fourier transform (FFT) functions, and discrete cosine transform (DCT) functions.

Along with the embedded multipliers, the M4K memory blocks in Cyclone II devices also support various soft multiplier implementations. These, in combination with the embedded multipliers increase the available number of multipliers in Cyclone II devices and provide the user with a wide variety of implementation options and flexibility when designing their systems.



See the Cyclone II Device Family Data Sheet section in Volume 1 of the *Cyclone II Device Handbook* for more information on Cyclone II devices.

Embedded Multiplier Block Overview

Each Cyclone II device has one to three columns of embedded multipliers that implement multiplication functions. [Figure 12–1](#) shows one of the embedded multiplier columns with the surrounding LABs. Each embedded multiplier can be configured to support one 18×18 multiplier or two 9×9 multipliers.

Figure 12–1. Embedded Multipliers Arranged in Columns with Adjacent LABs

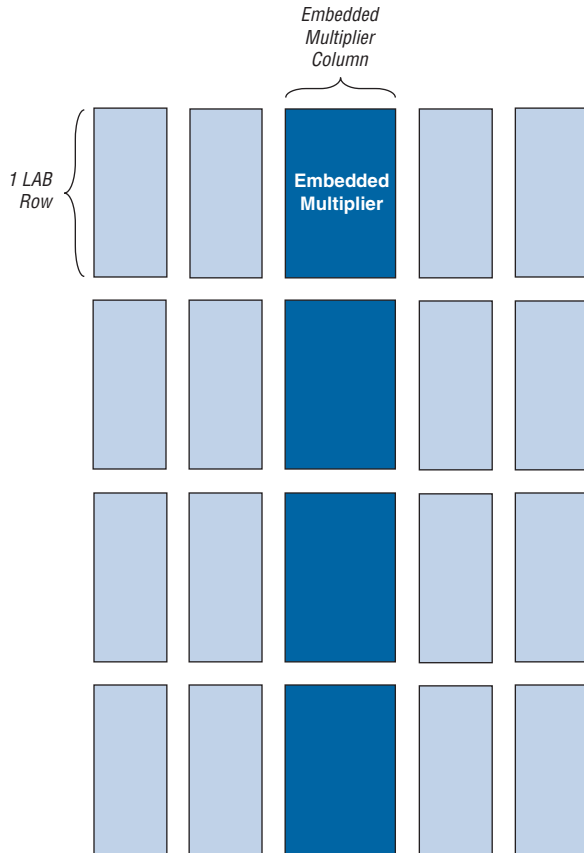

The number of embedded multipliers per column and the number of columns available increases with device density. Table 12–1 shows the number of embedded multipliers in each Cyclone II device and the multipliers that you can implement.

Table 12–1. Number of Embedded Multipliers in Cyclone II Devices (Part 1 of 2)			
Device	Embedded Multipliers	9 × 9 Multipliers (1)	18 × 18 Multipliers (1)
EP2C5	13	26	13
EP2C8	18	36	18

Table 12–1. Number of Embedded Multipliers in Cyclone II Devices (Part 2 of 2)

Device	Embedded Multipliers	9 × 9 Multipliers (1)	18 × 18 Multipliers (1)
EP2C20	26	52	26
EP2C35	35	70	35
EP2C50	86	172	86
EP2C70	150	300	150

Note to Table 12–1:

- (1) Each device has either the number of 9 × 9 or 18 × 18 multipliers shown. The total number of multipliers for each device is not the sum of all the multipliers.

In addition to the embedded multipliers, you can also implement soft multipliers using Cyclone II M4K memory blocks. The availability of soft multipliers increases the number of multipliers available within the device. Table 12–2 shows the total number of multipliers available in Cyclone II devices using embedded multipliers and soft multipliers.

Table 12–2. Number of Multipliers in Cyclone II Devices

Device	Embedded Multipliers (18 × 18)	Soft Multipliers (16 × 16) (1)	Total Multipliers (2)
EP2C5	13	26	39
EP2C8	18	36	54
EP2C20	26	52	78
EP2C35	35	105	140
EP2C50	86	129	215
EP2C70	150	250	400

Notes to Table 12–2:

- (1) Soft multipliers are implemented in sum of multiplication mode. The M4K memory blocks are configured with 18-bit data widths to support 16-bit coefficients. The sum of the coefficients requires 18 bits of resolution to account for overflow.
- (2) The total number of multipliers may vary according to the multiplier mode used.

See the *Cyclone II Memory Blocks* chapter in Volume 1 of the *Cyclone II Device Handbook* for more information on Cyclone II M4K memory blocks.



Refer to AN 306: *Techniques for Implementing Multipliers in FPGA Devices* for more information on soft multipliers.

Architecture

Each embedded multiplier consists of the following elements:

- Multiplier stage
- Input and output registers
- Input and output interfaces

Figure 12-2 shows the multiplier block architecture.

Figure 12-2. Multiplier Block Architecture

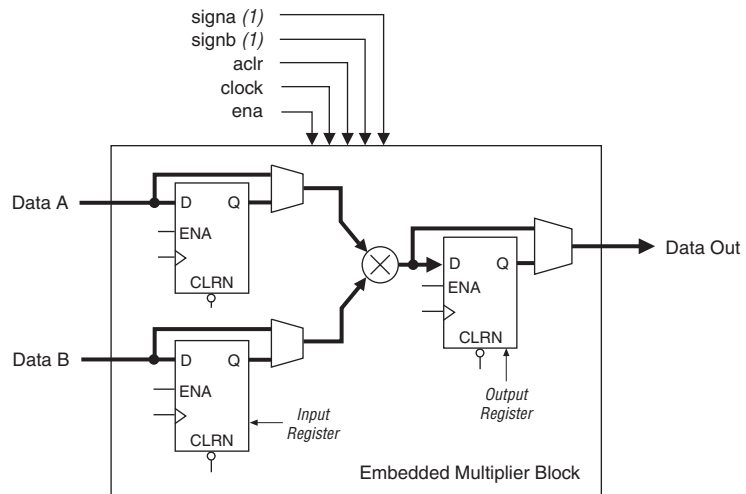

Note to Figure 12-2:

- (1) If necessary, you can send these signals through one register to match the data signal path.

Input Registers

You can send each multiplier input signal into an input register or directly into the multiplier in 9- or 18-bit sections depending on the operational mode of the multiplier. You can send each multiplier input signal through a register independently of each other (e.g., you can send the multiplier's data A signal through a register and send the data B signal directly to the multiplier). The following control signals are available to each register within the embedded multiplier:

- clock
- clock enable
- asynchronous clear

All input and output registers within a single embedded multiplier are fed by the same clock, clock enable, or asynchronous clear signal.

Multiplier Stage

The multiplier stage supports 9×9 or 18×18 multipliers as well as other smaller multipliers in between these configurations. See “Operational Modes” on page 12–6 for details. Depending on the data width or operational mode of the multiplier, a single embedded multiplier can perform one or two multiplications in parallel.

Each multiplier operand can be a unique signed or unsigned number. Two signals, `signa` and `signb`, control whether a multiplier’s input is a signed or unsigned value. If the `signa` signal is high, the data A operand is a signed number, and if the `signa` signal is low, the data A operand is an unsigned number. Table 12–3 shows the sign of the multiplication result for the various operand sign representations. The result of the multiplication is signed if any one of the operands is a signed value.

Table 12–3. Multiplier Sign Representation

Data A		Data B		Result
signa Value	Logic Level	signb Value	Logic Level	
Unsigned	Low	Unsigned	Low	Unsigned
Unsigned	Low	Signed	High	Signed
Signed	High	Unsigned	Low	Signed
Signed	High	Signed	High	Signed

There is only one `signa` and one `signb` signal for each embedded multiplier. The `signa` and `signb` signals can be changed dynamically to modify the sign representation of the input operands at run time. You can send the `signa` and `signb` signals through a dedicated input register. The multiplier offers full precision regardless of the sign representation.



When the `signa` and `signb` signals are unused, the Quartus® II software sets the multiplier to perform unsigned multiplication by default.

Output Registers

You can choose to register the embedded multiplier output using the output registers in 18- or 36-bit sections depending on the operational mode of the multiplier. The following control signals are available to each output register within the embedded multiplier:

- clock
- clock enable
- asynchronous clear

All input and output registers within a single embedded multiplier are fed by the same clock, clock enable, or asynchronous clear signal.



See the *Cyclone II Architecture* chapter in Volume 1 of the *Cyclone II Device Handbook* for more information on the embedded multiplier routing and interface.

Operational Modes

The embedded multiplier can be used in one of two operational modes, depending on the application needs:

- One 18-bit multiplier
- Up to two 9-bit independent multipliers

The Quartus II software includes megafunctions used to control the mode of operation of the multipliers. After you have made the appropriate parameter settings using the megafunction's MegaWizard® Plug-In Manager, the Quartus II software automatically configures the embedded multiplier.



The Cyclone II embedded multipliers can also be used to implement multiplier adder and multiplier accumulator functions where the multiplier portion of the function is implemented using embedded multipliers and the adder or accumulator function is implemented in logic elements (LEs).



For more information on megafunction and Quartus II support for Cyclone II embedded multipliers, see the [“Software Support”](#) section.

18-Bit Multipliers

Each embedded multiplier can be configured to support a single 18×18 multiplier for input widths from 10- to 18-bits. [Figure 12-3](#) shows the embedded multiplier configured to support an 18-bit multiplier.

Figure 12-3. 18-Bit Multiplier Mode

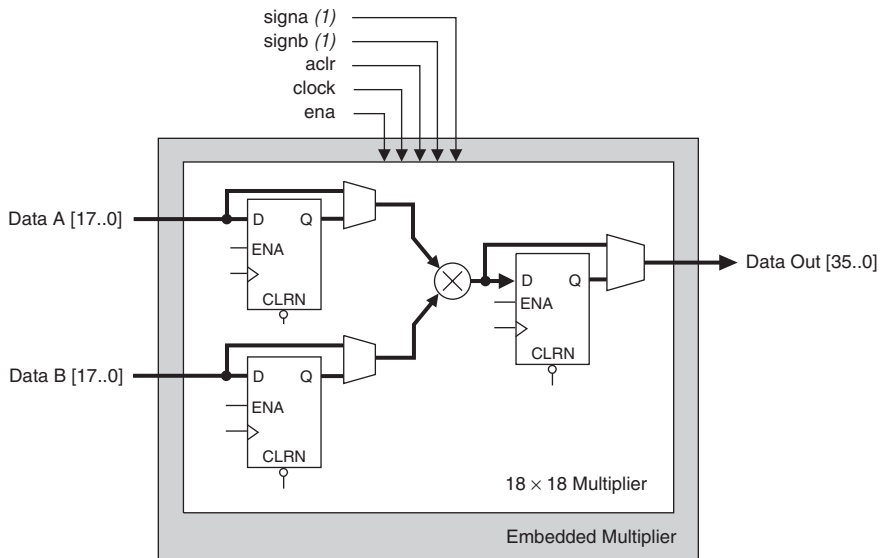

Note to Figure 12-3:

- (1) If necessary, you can send these signals through one register to match the data signal path.

All 18-bit multiplier inputs and results can be independently sent through registers. The multiplier inputs can accept signed integers, unsigned integers or a combination of both. Additionally, you can change the *signa* and *signb* signals dynamically and can send these signals through dedicated input registers.

9-Bit Multipliers

Each embedded multiplier can also be configured to support two 9×9 independent multipliers for input widths up to 9-bits. Figure 12-4 shows the embedded multiplier configured to support two 9-bit multipliers.

Software Support

Altera provides two methods for implementing multipliers in your design using embedded multiplier resources: instantiation and inference. Both methods use the following three Quartus II megafunctions:

- `lpm_mult`
- `altmult_add`
- `altmult_accum`

You can instantiate the megafunctions in the Quartus II software to use the embedded multipliers. You can use the `lpm_mult` and `altmult_add` megafunctions to implement multipliers. Additionally, you can use the `altmult_add` megafunctions to implement multiplier-adders where the embedded multiplier is used to implement the multiply function and the adder function is implemented in LEs. The `altmult_accum` megafunction implements multiply accumulate functions where the embedded multiplier implements the multiplier and the accumulator function is implemented in LEs.



See Quartus II On-Line Help for instructions on using the megafunctions and the MegaWizard Plug-In Manager.

You can also infer the megafunctions by creating an HDL design and synthesize it using Quartus II Native Synthesis or a third-party synthesis tool like LeonardoSpectrum™ or Synplify that recognizes and infers the appropriate multiplier megafunction. Using either method, the Quartus II software maps the multiplier functionality to the embedded multipliers during compilation.



See the Synthesis section in Volume 1 of the *Quartus II Development Software Handbook* for more information.

Conclusion

The Cyclone II device embedded multipliers are optimized to support multiplier-intensive DSP applications such as FIR filters, FFT functions and encoders. These embedded multipliers can be configured to implement multipliers of various bit widths up to 18-bits to suit a particular application resulting in efficient resource utilization and improved performance and data throughput. The Quartus II software, together with the LeonardoSpectrum and Synplify software provide a complete and easy-to-use flow for implementing multiplier functions using embedded multipliers.

This section provides configuration information for all of the supported configuration schemes for Cyclone™ II devices. These configuration schemes use either a microprocessor, configuration device, or download cable. There is detailed information on how to design with Altera® configuration devices. The last chapter provides information on JTAG support in Cyclone II devices.

This section includes the following chapters:

- [Chapter 13, Configuring Cyclone II Devices](#)
- [Chapter 14, IEEE 1149.1 \(JTAG\) Boundary-Scan Testing for Cyclone II Devices](#)

Revision History

The table below shows the revision history for [Chapters 13](#) and [14](#).

Chapter(s)	Date / Version	Changes Made
13	November 2004, v1.1	<ul style="list-style-type: none"> ● Updated “Configuration Stage” section in “Single Device AS Configuration” section. ● Updated “Initialization Stage” section in “Single Device AS Configuration” section. ● Updated Figure 13–8. ● Updated “Initialization Stage” section in “Single Device PS Configuration Using a MAX II Device as an External Host” section. ● Updated Table 13–7. ● Updated “Single Device PS Configuration Using a Configuration Device” section. ● Updated “Initialization Stage” section in “Single Device PS Configuration Using a Configuration Device” section. ● Updated Figure 13–18. ● Updated “Single Device JTAG Configuration” section.
	June 2004, v1.0	Added document to the Cyclone II Device Handbook.
14	June 2004, v1.0	Added document to the Cyclone II Device Handbook.

Introduction

Cyclone™ II devices use SRAM cells to store configuration data. Since SRAM memory is volatile, configuration data must be downloaded to Cyclone II devices each time the device powers up. You can use the active serial (AS) configuration scheme, which can operate at a DCLK frequency up to 40 MHz, to configure Cyclone II devices. You can also use the passive serial (PS) and Joint Test Action Group (JTAG)-based configuration schemes to configure Cyclone II devices. Additionally, Cyclone II devices can receive a compressed configuration bitstream and decompress this data on-the-fly, reducing storage requirements and configuration time.

This chapter explains the Cyclone II configuration features and describes how to configure Cyclone II devices using the supported configuration schemes. This chapter also includes configuration pin descriptions and the Cyclone II configuration file format.



For more information on setting device configuration options or creating configuration files, see the *Software Settings* chapter in the *Configuration Handbook*.

Cyclone II Configuration Overview

You can use the AS, PS, and JTAG configuration schemes to configure Cyclone II devices. You can select which configuration scheme to use by driving the Cyclone II device MSEL pins either high or low as shown in [Table 13-1](#). The MSEL pins are powered by the V_{CCIO} power supply of the bank they reside in. During power-on reset (POR) and reconfiguration, the MSEL pins have to be at LVTTTL V_{IL} or V_{IH} levels to be considered a logic low or logic high, respectively. Therefore, to avoid any problems with detecting an incorrect configuration scheme, you should connect the MSEL [] pins to the V_{CCIO} of the I/O bank they reside in and GND without any pull-up or pull-down resistors. The MSEL [] pins should not be driven by a microprocessor or another device.

Table 13–1. Cyclone II Configuration Schemes

Configuration Scheme	MSEL1	MSELO
AS (20 MHz) (1)	0	0
PS	0	1
Fast AS (40 MHz) (1)	1	0
JTAG-based Configuration (2)	(3)	(3)

Notes to Table 13–1:

- (1) Only the EPCS16 and EPCS64 devices support a DCLK up to 40 MHz. Other EPCS devices support a DCLK up to 20 MHz. See the *Serial Configuration Devices Data Sheet* for more information.
- (2) JTAG-based configuration takes precedence over other configuration schemes, which means MSEL pin settings are ignored.
- (3) Do not leave the MSEL pins floating; connect them to V_{CCIO} or ground. These pins support the non-JTAG configuration scheme used in production. If you are only using JTAG configuration, you should connect the MSEL pins to ground.

You can download configuration data to Cyclone II FPGAs with the AS, PS, or JTAG interfaces using the options in [Table 13–2](#).

Table 13–2. Cyclone II Device Configuration Schemes

Configuration Scheme	Description
AS configuration	Configuration using serial configuration devices (EPCS1, EPCS4, EPCS16 or EPCS64 devices)
PS configuration	Configuration using enhanced configuration devices (EPC4, EPC8, and EPC16 devices), EPC2 and EPC1 configuration devices, an intelligent host (microprocessor), or a download cable
JTAG-based configuration	Configuration via JTAG pins using a download cable, an intelligent host (microprocessor), or the Jam™ Standard Test and Programming Language (STAPL)

Configuration File Format

Table 13–3 shows the approximate uncompressed configuration file sizes for Cyclone II devices. To calculate the amount of storage space required for multiple device configurations, add the file size of each device together.

Device	Data Size (Bits)	Data Size (Bytes)
EP2C5	1,265,792	152,998
EP2C8	1,983,536	247,974
EP2C20	3,892,496	486,562
EP2C35	6,858,656	857,332
EP2C50	9,963,392	1,245,424
EP2C70	14,319,216	1,789,902

Note to Table 13–3:

(1) These values are preliminary.

Use the data in Table 13–3 only to estimate the file size before design compilation. Different configuration file formats, such as a Hexadecimal (.hex) or Tabular Text File (.ttf) format, will have different file sizes. However, for any specific version of the Quartus® II software, any design targeted for the same device will have the same uncompressed configuration file size. If compression is used, the file size can vary after each compilation since the compression ratio is dependent on the design.

Configuration Data Compression

Cyclone II devices support configuration data decompression, which saves configuration memory space and time. This feature allows you to store compressed configuration data in configuration devices or other memory and transmit this compressed bitstream to Cyclone II devices. During configuration, the Cyclone II device decompresses the bitstream in real time and programs its SRAM cells.



Preliminary data indicates that compression reduces configuration bitstream size by 35 to 55%.

Cyclone II devices support decompression in the AS and PS configuration schemes. Decompression is not supported in JTAG-based configuration.

Although they both use the same compression algorithm, the decompression feature supported by Cyclone II devices is different from the decompression feature in enhanced configuration devices (EPC16, EPC8, and EPC4 devices). The data decompression feature in the enhanced configuration devices allows them to store compressed data and decompress the bitstream before transmitting it to the target devices.

In PS mode, you should use the Cyclone II decompression feature since sending compressed configuration data reduces configuration time. You should not use both the Cyclone II device and the enhanced configuration device decompression features simultaneously. The compression algorithm is not intended to be recursive and could expand the configuration file instead of compressing it further.

You should use the Cyclone II decompression feature during AS configuration if you need to save configuration memory space in the serial configuration device.

When you enable compression, the Quartus II software generates configuration files with compressed configuration data. This compressed file reduces the storage requirements in the configuration device or flash, and decreases the time needed to transmit the bitstream to the Cyclone II device. The time required by a Cyclone II device to decompress a configuration file is less than the time needed to transmit the configuration data to the FPGA.

There are two methods to enable compression for Cyclone II bitstreams: before design compilation (in the Compiler Settings menu) and after design compilation (in the **Convert Programming Files** window).

To enable compression in the project's compiler settings, select **Device** under the Assignments menu to bring up the settings window. After selecting your Cyclone II device open the **Device & Pin Options** window, and in the **General settings** tab enable the check box for **Generate compressed bitstreams** (see [Figure 13-1](#)).

Figure 13–1. Enabling Compression for Cyclone II Bitstreams in Compiler Settings

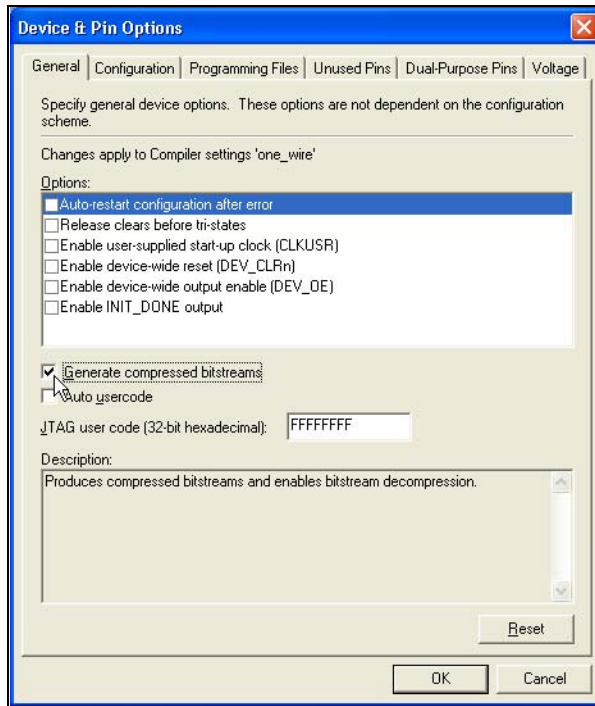

You can also use the following steps to enable compression when creating programming files from the Convert Programming Files window.

1. Click **Convert Programming Files** (File menu).
2. Select the Programming File type. Only Programmer Object Files (.pof), SRAM HEXOUT, RBF, or TTF files support compression.
3. For POFs, select a configuration device.
4. Select **Add File** and add a Cyclone II SRAM Object File(s) (.sof).
5. Select the name of the file you added to the SOF Data area and click on **Properties**.
6. Check the **Compression** check box.

When multiple Cyclone II devices are cascaded, the compression feature can be selectively enabled for each device in the chain. Figure 13–2 depicts a chain of two Cyclone II devices. The first Cyclone II device has compression enabled and therefore receives a compressed bitstream from the configuration device. The second Cyclone II device has the compression feature disabled and receives uncompressed data.

Figure 13–2. Compressed & Uncompressed Configuration Data in a Programming File

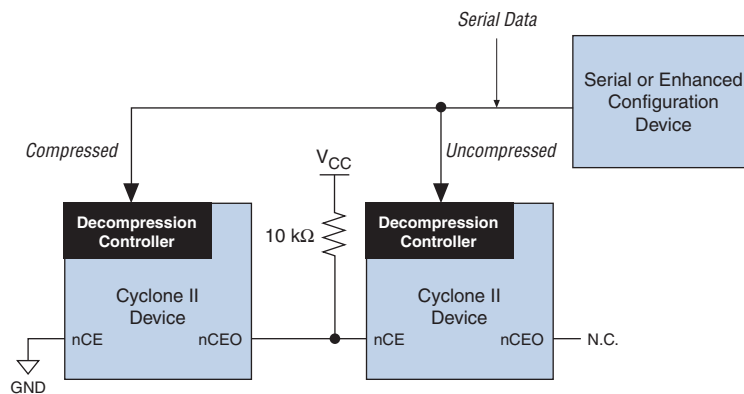

You can generate programming files (for example, POF files) for this setup in the Quartus II software.

Active Serial Configuration (Serial Configuration Devices)

In the AS configuration scheme, Cyclone II devices are configured using a serial configuration device. These configuration devices are low-cost devices with non-volatile memory that feature a simple, four-pin interface and a small form factor. These features make serial configuration devices an ideal low-cost configuration solution.



For more information on serial configuration devices, see the *Serial Configuration Devices Data Sheet* in the Configuration Handbook.

Serial configuration devices provide a serial interface to access configuration data. During device configuration, Cyclone II devices read configuration data via the serial interface, decompress data if necessary, and configure their SRAM cells. The FPGA controls the configuration interface in the AS configuration scheme, while the external host (e.g., the configuration device or microprocessor) controls the interface in the PS configuration scheme.



The Cyclone II decompression feature is available when configuring your Cyclone II device using AS mode.

Table 13–4 shows the MSEL pin settings when using the AS configuration scheme.

Configuration Scheme	MSEL1	MSEL0
AS (20 MHz) (1)	0	0
Fast AS (40 MHz) (1)	1	0

Note to Table 13–4:

- (1) The EPCS16 and EPCS64 supported a DCLK up to 40 MHz. Other EPCS devices support a DCLK up to 20 MHz. See the *Serial Configuration Devices Data Sheet* for more information.

Single Device AS Configuration

Serial configuration devices have a four-pin interface: serial clock input (DCLK), serial data output (DATA), AS data input (ASDI), and an active-low chip select (\overline{nCS}). This four-pin interface connects to Cyclone II device pins, as shown in Figure 13–3.

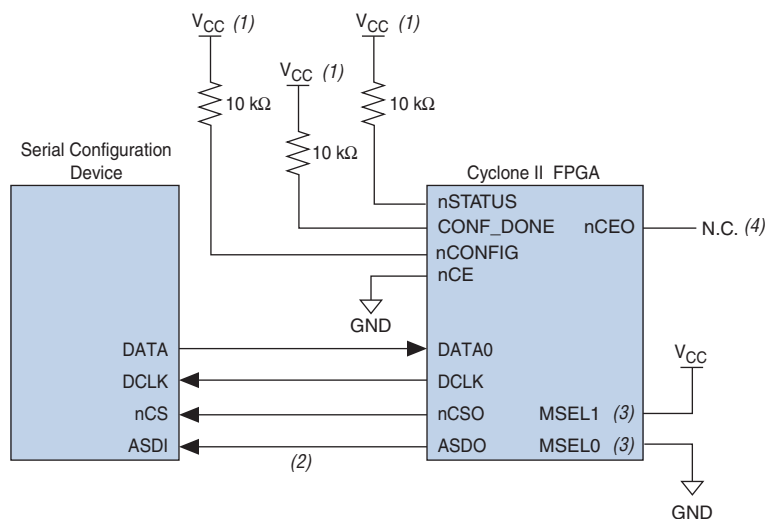
Figure 13–3. Single Device AS Configuration**Notes to Figure 13–3:**

- (1) Connect the pull-up resistors to a 3.3-V supply.
- (2) Cyclone II devices use the ASDO to ASDI path to control the configuration device.
- (3) If your design uses an EPCS4 or an EPCS1 device, set the MSEL[1..0] pins to 00. See [Table 13–4](#) for more details.
- (4) The nCEO pin can be left unconnected or used as a user I/O pin when it does not feed another device's nCE pin.

Upon power-up, the Cyclone II device goes through a POR. During POR, the device will reset, hold nSTATUS and CONF_DONE low, and tri-state all user I/O pins. After POR, which typically lasts 100 ms, the Cyclone II device releases nSTATUS and enters configuration mode when the external 10-kΩ resistor pulls the nSTATUS pin high. Once the FPGA successfully exits POR, all user I/O pins continue to be tri-stated. Cyclone II devices have weak pull-up resistors on the user I/O pins which are on before and during configuration.



The value of the weak pull-up resistors on the I/O pins that are on before and during configuration are available in the *DC Characteristics & Timing Specifications* chapter of the *Cyclone II Device Handbook*.

The configuration cycle consists of the reset, configuration, and initialization stages.

Reset Stage

When `nCONFIG` or `nSTATUS` are low, the device is in reset. After POR, the Cyclone II device releases `nSTATUS`. An external 10-k Ω pull-up resistor pulls the `nSTATUS` signal high, and the Cyclone II device enters configuration mode.



V_{CCINT} and V_{CCIO} of the banks where the configuration and JTAG pins reside need to be fully powered to the appropriate voltage levels in order to begin the configuration process.

Configuration Stage

The serial clock (DCLK) generated by the Cyclone II device controls the entire configuration cycle and provides the timing for the serial interface. Cyclone II devices use an internal oscillator to generate DCLK. Using the `MSEL []` pins, you can select either a 20- or 40-MHz oscillator. Although you can select either 20- or 40-MHz oscillator when designing with EPCS16 and EPCS64 serial configuration devices, the 40-MHz oscillator provides faster configuration times. There is some variation in the internal oscillator frequency because of the process, temperature, and voltage conditions in Cyclone II devices. The internal oscillator is designed such that its maximum frequency is guaranteed to meet EPCS device specifications.



Only the EPCS16 and EPCS64 configuration devices support a DCLK up to 40 MHz. Other serial configuration devices support a DCLK up to 20 MHz. See the *Serial Configuration Devices Data Sheet* for more information.

Table 13–5 shows the AS DCLK output frequencies.

Table 13–5. AS DCLK Output Frequency <i>Note (1)</i>				
Oscillator Selected	Minimum	Typical	Maximum	Units
40 MHz (2)	20	26	40	MHz
20 MHz	10	13	20	MHz

Notes to Table 13–5:

- (1) These values are preliminary.
- (2) The EPCS16 and EPCS64 devices support a DCLK clock up to 40 MHz. Other serial configuration devices support a DCLK clock up to 20 MHz. See the *Serial Configuration Devices Data Sheet* for more information.

The serial configuration device latches input/control signals on the rising edge of DCLK and drives out configuration data on the falling edge. Cyclone II devices drive out control signals on the falling edge of DCLK and latch configuration data on the rising edge of DCLK.

In configuration mode, the Cyclone II device enables the serial configuration device by driving its nCSO output pin low, which connects to the chip select (nCS) pin of the configuration device. The Cyclone II device uses the serial clock (DCLK) and serial data output (ASDO) pins to send operation commands and/or read address signals to the serial configuration device. The configuration device then provides data on its serial data output (DATA) pin, which connects to the DATA0 input of the Cyclone II device.

After the Cyclone II device receives all the configuration bits, it releases the open-drain CONF_DONE pin, which is then pulled high by an external 10-k Ω resistor. Also, the Cyclone II device stops driving the DCLK signal. Initialization begins only after the CONF_DONE signal reaches a logic high level. All AS configuration pins (DATA0, DCLK, nCSO, and ASDO) have weak internal pull-up resistors which are always active. Therefore, after configuration, these pins will be driven high.

Initialization Stage

In Cyclone II devices, the initialization clock source is either the Cyclone II 10-MHz (typical) internal oscillator (separate from the AS internal oscillator) or the optional CLKUSR pin. The internal oscillator is the default clock source for initialization. If the internal oscillator is used, the Cyclone II device will provide itself with enough clock cycles for proper initialization. The advantage of using the internal oscillator is you do not need to send additional clock cycles from an external source to the CLKUSR pin during the initialization stage. Additionally, you can use the CLKUSR pin as a user I/O pin.

If you want to delay the initialization of the device, you can use the CLKUSR pin option. Using the CLKUSR pin allows you to control when your device enters user mode. The device can be delayed from entering user mode for an indefinite amount of time. When you enable the **User Supplied Start-Up Clock** option, the CLKUSR pin is the initialization clock source. Supplying a clock on CLKUSR will not affect the configuration process. After all configuration data has been accepted and CONF_DONE goes high, Cyclone II devices require 299 clock cycles to initialize properly and support a CLKUSR f_{MAX} of 100 MHz.

Cyclone II devices offer an optional `INIT_DONE` pin which signals the end of initialization and the start of user mode with a low-to-high transition. The **Enable `INIT_DONE` output** option is available in the Quartus II software from the **General** tab of the **Device & Pin Options** window. If you use the `INIT_DONE` pin, an external 10-k Ω pull-up resistor is required to pull the signal high when `nCONFIG` is low and during the beginning of configuration. Once the optional bit to enable `INIT_DONE` is programmed into the device (during the first frame of configuration data), the `INIT_DONE` pin will go low. When initialization is complete, the `INIT_DONE` pin will be released and pulled high. This low-to-high transition signals that the FPGA has entered user mode. If you do not use the `INIT_DONE` pin, the initialization period will be complete after `CONF_DONE` goes high and 299 clock cycles are sent to the `CLKUSR` pin or after the time t_{CF2UM} (see Table 13–8) if the Cyclone II device uses the internal oscillator.

User Mode

When initialization is complete, the FPGA enters user mode. In user mode, the user I/O pins will no longer have weak pull-up resistors and will function as assigned in your design.

When the Cyclone II device is in user mode, you can initiate reconfiguration by pulling the `nCONFIG` signal low. The `nCONFIG` signal should be low for at least 40 μ s. When `nCONFIG` is pulled low, the Cyclone II device is reset and enters the reset stage. The Cyclone II device also pulls `nSTATUS` and `CONF_DONE` low and all I/O pins are tri-stated. Once `nCONFIG` returns to a logic high level and `nSTATUS` is released by the Cyclone II device, reconfiguration begins.

Error During Configuration

If an error occurs during configuration, the Cyclone II device drives the `nSTATUS` signal low to indicate a data frame error, and the `CONF_DONE` signal will stay low. If you enable the **Auto-restart configuration after error** option in the Quartus II software from the **General** tab of the **Device & Pin Options** dialog box, the Cyclone II device resets the serial configuration device by pulsing `nCSO`, releases `nSTATUS` after a reset time-out period (about 40 μ s), and retries configuration. If the **Auto-restart configuration after error** option is turned off, the external system must monitor `nSTATUS` for errors and then pull `nCONFIG` low for at least 40 μ s to restart configuration.



If you use the optional `CLKUSR` pin and the `nCONFIG` pin is pulled low to restart configuration during device initialization, ensure `CLKUSR` continues to toggle during the time `nSTATUS` is low (a maximum of 40 μ s).



For more information on configuration issues, see the *Debugging Configuration Problems* chapter of the *Configuration Handbook* and the FPGA Configuration Troubleshooter on the Altera web site (www.altera.com).

Multiple Device AS Configuration

You can configure multiple Cyclone II devices using a single serial configuration device. You can cascade multiple Cyclone II devices using the chip-enable (`nCE`) and chip-enable-out (`nCEO`) pins. Connect the `nCE` pin of the first device in the chain to ground and connect the `nCEO` pin to the `nCE` pin of the next device in the chain. Use an external 10-k Ω pull-up resistor to pull the `nCEO` signal high to its V_{CCIO} level to help the internal weak pull-up resistor. When the first device captures all of its configuration data from the bitstream, it transitions its `nCEO` pin low, initiating the configuration of the next device in the chain. You can leave the `nCEO` pin of the last device unconnected or use it as a user I/O pin after configuration if the last device in chain is a Cyclone II device.



The Quartus II software sets the Cyclone II device `nCEO` pin as an output pin driving to ground by default. If the device is in a chain, and the `nCEO` pin is connected to the next device's `nCE` pin, you must make sure that the `nCEO` pin is not used as a user I/O pin after configuration. The software setting is in the **Dual-Purpose Pins** tab of the **Device & Pin Options** dialog box in Quartus II software.

The first Cyclone II device in the chain is the configuration master and controls the configuration of the entire chain. Select the AS configuration scheme for the first Cyclone II device and the PS configuration scheme for the remaining Cyclone II devices (configuration slaves). Any other Altera® device that supports PS configuration can also be part of the chain as a configuration slave. In a multiple device chain, the `nCONFIG`, `nSTATUS`, `CONF_DONE`, `DCLK`, and `DATA0` pins of each device in the chain are connected (see [Figure 13-4](#)). [Figure 13-4](#) shows the pin connections for this setup.

Figure 13–4. Multiple Device AS Configuration

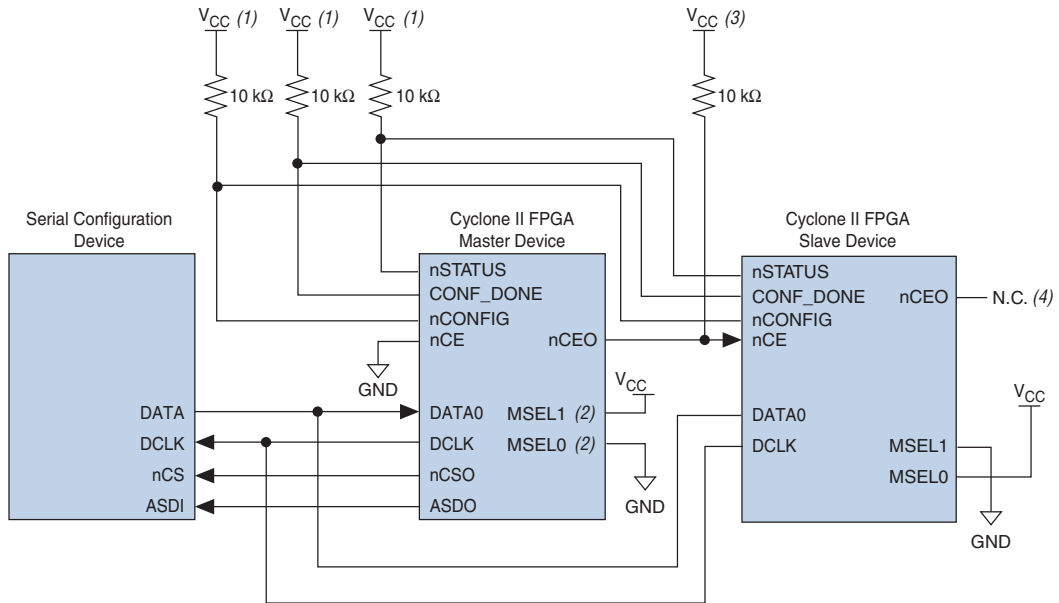
**Notes to Figure 13–4:**

- (1) Connect the pull-up resistors to a 3.3-V supply.
- (2) If using an EPCS4 or an EPCS1 device, set MSEL[1..0] to 00. See Table 13–4 for more details.
- (3) Connect the pull-up resistor to the V_{CCIO} supply voltage of I/O bank that the nCEO pin resides in.
- (4) The nCEO pin can be left unconnected or used as a user I/O pin when it does not feed another device's nCE pin.

As shown in Figure 13–4, the nSTATUS and CONF_DONE pins on all target FPGAs are connected together with external pull-up resistors. These pins are open-drain bidirectional pins on the FPGAs. When the first device asserts nCEO (after receiving all of its configuration data), it releases its CONF_DONE pin. However, the subsequent devices in the chain keep the CONF_DONE signal low until they receive their configuration data. When all the target FPGAs in the chain have received their configuration data and have released CONF_DONE, the pull-up resistor pulls this signal high, and all devices simultaneously enter initialization mode.

During initialization, the initialization clock source is either the Cyclone II 10 MHz (typical) internal oscillator (separate from the AS internal oscillator) or the optional CLKUSR pin. By default, the internal oscillator is the clock source for initialization. If the internal oscillator is used, the Cyclone II device will provide itself with enough clock cycles for proper initialization. The advantage of using the internal oscillator is you do not need to send additional clock cycles from an external source to the CLKUSR pin during the initialization stage. You can also make use of the CLKUSR pin as a user I/O pin, which means you have an additional user I/O pin.

If you want to delay the initialization of the devices in the chain, you can use the CLKUSR pin option. The CLKUSR pin allows you to control when your device enters user mode. This feature also allows you to control the order of when each device enters user mode by feeding a separate clock to each device's CLKUSR pin. By using the CLKUSR pins, you can choose any device in the multiple device chain to enter user mode first and have the other devices enter user mode at a later time.

Different device families may require a different number of initialization clock cycles. Therefore, if your multiple device chain consists of devices from different families, the devices may enter user mode at a slightly different time due to the different number of initialization clock cycles required. However, if the number of initialization clock cycles is similar across different device families or if the devices are from the same family, then the devices enter user mode at the same time. See the respective device family handbook for more information about the number of initialization clock cycles required.

If an error occurs at any point during configuration, the FPGA with the error drives the nSTATUS signal low. If you enable the **Auto-restart configuration after error** option, the entire chain begins reconfiguration after a reset time-out period (a maximum of 40 μ s). If the **Auto-restart configuration after error** option is turned off, a microprocessor or controller must monitor nSTATUS for errors and then pulse nCONFIG low to restart configuration. The microprocessor or controller can pulse nCONFIG if it is under system control rather than tied to V_{CC}.



While you can cascade Cyclone II devices, serial configuration devices cannot be cascaded or chained together.



If you use the optional CLKUSR pin and the nCONFIG is pulled low to restart configuration during device initialization, make sure the CLKUSR pin continues to toggle while nSTATUS is low (a maximum of 40 μ s).

If the configuration bitstream size exceeds the capacity of a serial configuration device, you must select a larger configuration device and/or enable the compression feature. When configuring multiple devices, the size of the bitstream is the sum of the individual devices' configuration bitstreams.

Configuring Multiple Cyclone II Devices with the Same Design

Certain designs require you to configure multiple Cyclone II devices with the same design through a configuration bitstream or SOF. You can do this through one of two methods, as described in this section. For both methods, the serial configuration devices cannot be cascaded or chained together.

Multiple SOFs

In the first method, two copies of the SOF file are stored in the serial configuration device. Use the first copy to configure the master Cyclone II device and the second copy to configure all remaining slave devices concurrently. In this setup, the master Cyclone II device is in AS mode, and the slave Cyclone II devices are in PS mode (MSEL=01). See [Figure 13–5](#).

To configure four identical Cyclone II devices with the same SOF file, connect the three slave devices for concurrent configuration as shown in [Figure 13–5](#). The nCEO pin from the master device drives the nCE input pins on all three slave devices. Connect the configuration device's DATA and DCLK pins to the Cyclone II device's DATA and DCLK pins in parallel. During the first configuration cycle, the master device reads its configuration data from the serial configuration device while holding nCEO high. After completing its configuration cycle, the master drives nCE low and transmits the second copy of the configuration data to all three slave devices, configuring them simultaneously.

The advantage of using the setup in [Figure 13–5](#) is that you can have a different SOF file for the Cyclone II master device. However, all the Cyclone II slave devices must be configured with the same SOF file. The SOF files in this configuration method can be either compressed or uncompressed.



You can still use this method if the master and slave Cyclone II devices use the same SOF.

Single SOF

The second method configures both the master and slave Cyclone II devices with the same SOF. The serial configuration device stores one copy of the SOF file. This setup is shown in [Figure 13–6](#) where the master is setup in AS mode, and the slave devices are setup in PS mode (MSEL=01). You could setup one or more slave devices in the chain and all the slave devices are setup in the same way as shown in [Figure 13–6](#).

Figure 13–6. Multiple Device AS Configuration When FPGAs Receive the Same Data with a Single SOF

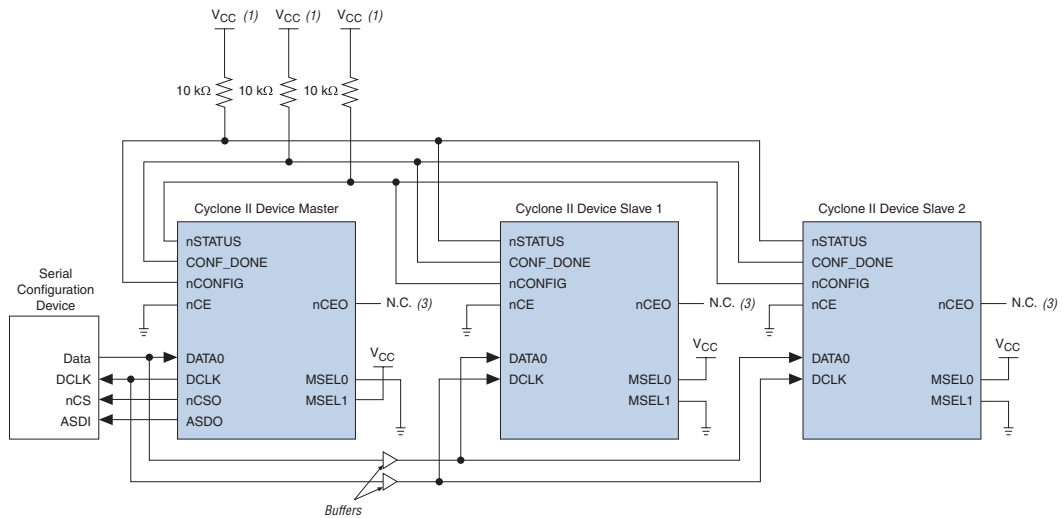

Notes to [Figure 13–6](#):

- (1) Connect the pull-up resistors to a 3.3-V supply.
- (2) If your design uses an EPCS4 or EPCS1 device, set the MSEL [1 . . 0] pins to 00. See [Table 13–4](#) for more details.
- (3) The nCEO pin can be left unconnected or used as a user I/O pin when it does not feed another device's nCE pin.

In this setup, all the Cyclone II devices in the chain are connected for concurrent configuration. This can reduce the AS configuration time because all the Cyclone II devices are configured in one configuration cycle. Connect the nCE input pins of all the Cyclone II devices to ground. You can either leave the nCEO output pins on all the Cyclone II devices unconnected or use the nCEO output pins as normal user I/O pins. The DATA and DCLK pins are connected in parallel to all the Cyclone II devices.

You should put a buffer before the DATA and DCLK output from the master Cyclone II device to avoid signal strength and signal integrity issues. The buffer should not significantly change the DATA-to-DCLK relationships or delay them with respect to other AS signals (ASDI and nCS). Also, the buffer should only drive the slave Cyclone II devices, so that the timing between the master Cyclone II device and serial configuration device is unaffected.

This configuration method supports both compressed and uncompressed SOFs. Therefore, if the configuration bitstream size exceeds the capacity of a serial configuration device, you can enable the compression feature in the SOF file used or you can select a larger serial configuration device.

Estimating AS Configuration Time

The AS configuration time is the time it takes to transfer data from the serial configuration device to the Cyclone II device. The Cyclone II DCLK output (generated from an internal oscillator) clocks this serial interface. As listed in Table 13-5, if you are using the 40-MHz oscillator, the DCLK minimum frequency is 20 MHz (50 ns). Therefore, the maximum configuration time estimate for an EP2C5 device (1,223,980 bits of uncompressed data) is:

$$\text{RBF size} \times (\text{maximum DCLK period} / 1 \text{ bit per DCLK cycle}) = \text{estimated maximum configuration time}$$

$$1,223,980 \text{ bits} \times (50 \text{ ns} / 1 \text{ bit}) = 61.2 \text{ ms}$$

To estimate the typical configuration time, use the typical DCLK period listed in Table 13-5. With a typical DCLK period of 38.46 ns, the typical configuration time is 47.1 ms. Enabling compression reduces the amount of configuration data that is transmitted to the Cyclone II device, which also reduces configuration time. On average, compression reduces configuration time by 50%.

Programming Serial Configuration Devices

Serial configuration devices are non-volatile, flash-memory-based devices. You can program these devices in-system using the USB-Blaster™ or ByteBlaster™ II download cable. Alternatively, you can program them using the Altera Programming Unit (APU), supported third-party programmers, or a microprocessor with the SRRunner software driver.

You can use the AS programming interface to program serial configuration devices in-system. During in-system programming, the download cable disables FPGA access to the AS interface by driving the nCE pin high. Cyclone II devices are also held in reset by pulling the nCONFIG signal low. After programming is complete, the download cable releases the nCE and nCONFIG signals, allowing the pull-down and pull-up resistor to drive GND and V_{CC}, respectively. Figure 13–7 shows the download cable connections to the serial configuration device.



For more information on the USB-Blaster download cable, see the *USB-Blaster USB Port Download Cable Data Sheet*. For more information on the ByteBlaster II cable, see the *ByteBlaster II Download Cable Data Sheet*.

Figure 13–7. In-System Programming of Serial Configuration Devices

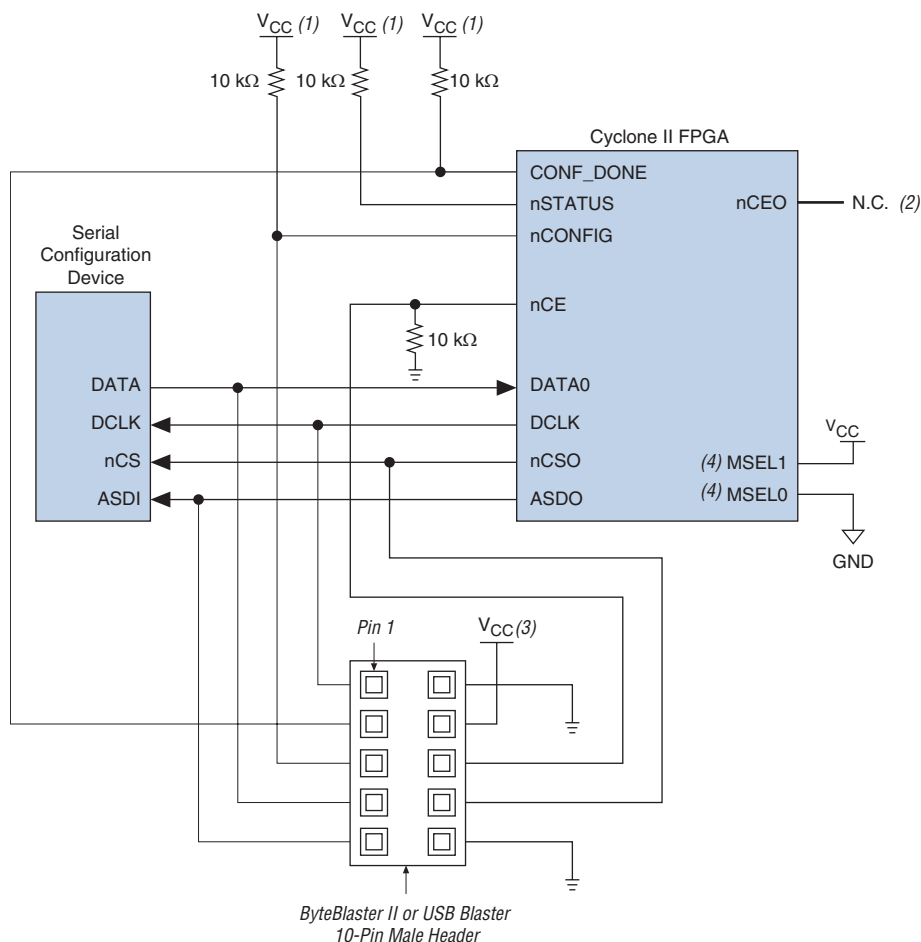
**Notes to Figure 13–7:**

- (1) Connect these pull-up resistors to 3.3-V supply.
- (2) The nCEO pin can be left unconnected or used as a user I/O pin when it does not feed other device's nCE pin.
- (3) Power up the ByteBlaster II or USB Blaster cable's V_{CC} with a 3.3-V supply.
- (4) If using an EPCS4 or an EPCS1 device, set the MSEL[1..0] pins to 00. See Table 13–4 for more details.

You can use the Quartus II software with the APU and the appropriate configuration device programming adapter to program serial configuration devices. All serial configuration devices are offered in an 8-pin or 16-pin small outline integrated circuit (SOIC) package and can be programmed using the PLMSEPC-8 adapter.

Altera programming hardware (APU) or other third-party programming hardware can be used to program blank serial configuration devices before they are mounted onto PCBs. Alternatively, you can use an on-board microprocessor to program the serial configuration device on the PCB using C-based software drivers provided by Altera (i.e., the SRrunner software driver).

A serial configuration device can be programmed in-system by an external microprocessor using SRrunner. SRrunner is a software driver developed for embedded serial configuration device programming, which can be easily customized to fit in different embedded systems. SRrunner can read a Raw Programming Data File (.rpd) and write to the serial configuration devices. The serial configuration device programming time using SRrunner is comparable to the programming time when using the Quartus II Programmer.



For more information about SRrunner, see the *SRrunner: An Embedded Solution for EPCS Programming White Paper* and the source code on the Altera web site at www.altera.com. For more information on programming serial configuration devices, see the *Serial Configuration Devices Data Sheet* in the *Configuration Handbook*.

Figure 13–8 shows the timing waveform for the AS configuration scheme using a serial configuration device.

Figure 13–8. AS Configuration Timing

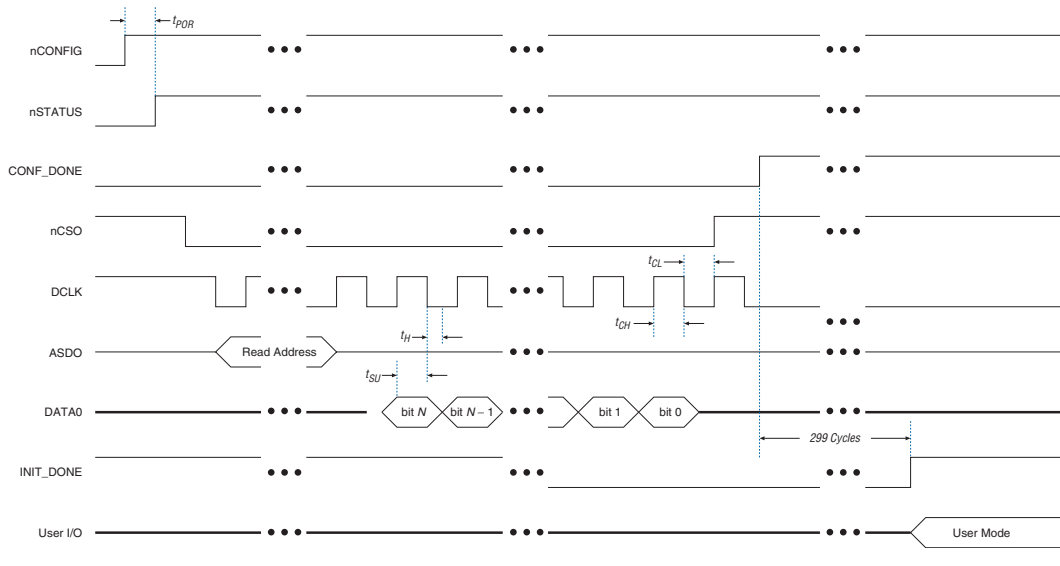

PS Configuration

You can use an Altera configuration device, a download cable, or an intelligent host, such as a MAX[®] II device or microprocessor to configure a Cyclone II device with the PS scheme. In the PS scheme, an external host (configuration device, MAX II device, embedded processor, or host PC) controls configuration. Configuration data is input to the target Cyclone II devices via the DATA0 pin at each rising edge of DCLK.



The Cyclone II decompression feature is fully available when configuring your Cyclone II device using PS mode.

Table 13–6 shows the MSEL pin settings when using the PS configuration scheme.

Configuration Scheme	MSEL1	MSEL0
PS	0	1

Single Device PS Configuration Using a MAX II Device as an External Host

In the PS configuration scheme, you can use a MAX II device as an intelligent host that controls the transfer of configuration data from a storage device, such as flash memory, to the target Cyclone II device. Configuration data can be stored in RBF, HEX, or TTF format. Figure 13–9 shows the configuration interface connections between the Cyclone II device and a MAX II device for single device configuration.

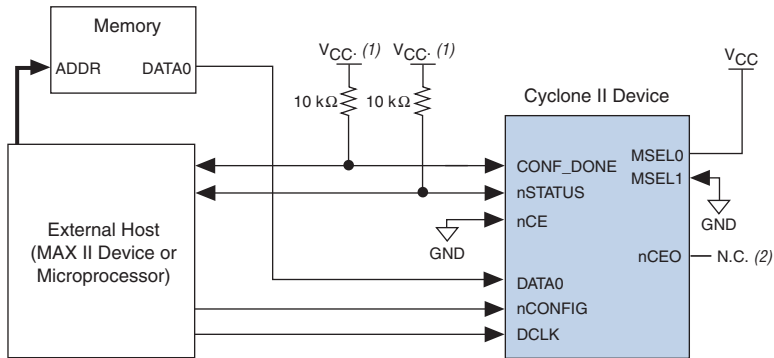
Figure 13–9. Single Device PS Configuration Using an External Host**Notes to Figure 13–9:**

- (1) Connect the pull-up resistor to a supply that provides an acceptable input signal for the device. V_{CC} should be high enough to meet the V_{IH} specification of the I/O on the device and the external host.
- (2) The nCEO pin can be left unconnected or used as a user I/O pin when it does not feed other device's nCE pin.

Upon power-up, the Cyclone II device goes through a POR, which lasts approximately 100 ms. During POR, the device will reset, hold nSTATUS low, and tri-state all user I/O pins. Once the FPGA successfully exits POR, all user I/O pins continue to be tri-stated.



The value of the weak pull-up resistors on the I/O pins that are on before and during configuration can be found in the *Cyclone II Device Handbook*.

The configuration cycle consists of three stages: reset, configuration, and initialization.

Reset Stage

While the Cyclone II device's nCONFIG or nSTATUS pins are low, the device is in reset. To initiate configuration, the MAX II device must transition the Cyclone II nCONFIG pin from low to high.



V_{CCINT} and V_{CCIO} of the banks where the configuration and JTAG pins reside need to be fully powered to the appropriate voltage levels in order to begin the configuration process.

When the Cyclone II nCONFIG pin transitions high, the Cyclone II device comes out of reset and releases the open-drain nSTATUS pin, which is then pulled high by an external 10-kΩ pull-up resistor. Once nSTATUS is released, the FPGA is ready to receive configuration data and the MAX II device can start the configuration at any time.

Configuration Stage

After the Cyclone II device's `nSTATUS` pin transitions high, the MAX II device should send the configuration data on the `DATA0` pin one bit at a time. If you are using configuration data in RBF, HEX, or TTF format, send the least significant bit (LSB) of each data byte first. For example, if the RBF contains the byte sequence 02 1B EE 01 FA, you should transmit the serial bitstream 0100-0000 1101-1000 0111-0111 1000-0000 0101-1111 to the device first.

The Cyclone II device receives configuration data on its `DATA0` pin and the clock on the `DCLK` pin. Data is latched into the FPGA on the rising edge of `DCLK`. Data is continuously clocked into the target device until the `CONF_DONE` pin transitions high. After the Cyclone II device receives all the configuration data successfully, it releases the open-drain `CONF_DONE` pin, which is pulled high by an external 10-k Ω pull-up resistor. A low-to-high transition on `CONF_DONE` indicates configuration is complete and initialization of the device can begin.

The configuration clock (`DCLK`) speed must be below the specified system frequency (see [Table 13-7](#)) to ensure correct configuration. No maximum `DCLK` period exists, which means you can pause configuration by halting `DCLK` for an indefinite amount of time.

Initialization Stage

In Cyclone II devices, the initialization clock source is either the Cyclone II internal oscillator (typically 10 MHz) or the optional `CLKUSR` pin. The internal oscillator is the default clock source for initialization. If you use the internal oscillator, the Cyclone II device will make sure to provide enough clock cycles for proper initialization. Therefore, if the internal oscillator is the initialization clock source, sending the entire configuration file to the device is sufficient to configure and initialize the device. You do not need to provide additional clock cycles externally during the initialization stage. Driving `DCLK` back to the device after configuration is complete does not affect device operation. Additionally, if you use the internal oscillator as the clock source, you can use the `CLKUSR` pin as a user I/O pin.

If you want to delay the initialization of the device, you can use the `CLKUSR` pin. Using the `CLKUSR` pin allows you to control when your device enters user mode. You can delay the device from entering user mode for an indefinite amount of time.

The **Enable user-supplied start-up clock (CLKUSR)** option can be turned on in the Quartus II software from the **General** tab of the **Device & Pin Options** dialog box. Supplying a clock on CLKUSR will not affect the configuration process. After all configuration data has been accepted and CONF_DONE goes high, Cyclone II devices require 299 clock cycles to initialize properly and support a CLKUSR f_{MAX} of 100 MHz.



If the optional CLKUSR pin is being used and nCONFIG is pulled low to restart configuration during device initialization, you need to ensure that CLKUSR continues toggling during the time nSTATUS is low (maximum of 40 μ s).

An optional INIT_DONE pin signals the end of initialization and the start of user mode with a low-to-high transition. By default, the INIT_DONE output is disabled. You can enable the INIT_DONE output by turning on the **Enable INIT_DONE output** option in the Quartus II software. If you use the INIT_DONE pin, an external 10-k Ω pull-up resistor pulls the pin high when nCONFIG is low and during the beginning of configuration. Once the optional bit to enable INIT_DONE is programmed into the device (during the first frame of configuration data), the INIT_DONE pin transitions low. When initialization is complete, the INIT_DONE pin will be released and pulled high. The MAX II device must be able to detect this low-to-high transition, which signals the FPGA has entered user mode.

If you want to use the INIT_DONE pin as a user I/O pin, you should wait for the maximum value of t_{CD2UM} (see [Table 13-7](#)) after the CONF_DONE signal transitions high so to ensure the Cyclone II device has been initialized properly and is in user mode.

Make sure the MAX II device does not drive the CONF_DONE signal low during configuration, initialization, and before the device enters user mode.

User Mode

When initialization is complete, the Cyclone II device enters user mode. In user mode, the user I/O pins no longer have pull-up resistors and will function as assigned in your design.

To ensure DCLK and DATA0 are not left floating at the end of configuration, the MAX II device must drive them either high or low, which ever is convenient on your PCB. The Cyclone II device DATA0 pin is not available as a user I/O pin after configuration.

When the FPGA is in user mode, you can initiate a reconfiguration by transitioning the `nCONFIG` pin low-to-high. The `nCONFIG` pin must be low for at least 40 μ s. When the `nCONFIG` transitions low, the Cyclone II device also pulls `nSTATUS` and `CONF_DONE` low and tri-states all I/O pins. Once the `nCONFIG` pin returns to a logic high level and the Cyclone II device releases the `nSTATUS` pin, the MAX II device can begin reconfiguration.

Error During Configuration

If an error occurs during configuration, the Cyclone II device transitions its `nSTATUS` pin low, resetting itself internally. The low signal on the `nSTATUS` pin tells the MAX II device that there is an error. If you turn on the **Auto-restart configuration after error** option in the Quartus II software, the Cyclone II device releases `nSTATUS` after a reset time-out period (maximum of 40 μ s). After `nSTATUS` is released and pulled high by a pull-up resistor, the MAX II device can try to reconfigure the target device without needing to pulse `nCONFIG` low. If this option is turned off, the MAX II device must generate a low-to-high transition (with a low pulse of at least 40 μ s) on `nCONFIG` to restart the configuration process.

The MAX II device can also monitor the `CONF_DONE` and `INIT_DONE` pins to ensure successful configuration. The MAX II device must monitor the Cyclone II device's `CONF_DONE` pin to detect errors and determine when programming completes. If all configuration data is sent, but `CONF_DONE` or `INIT_DONE` do not transition high, the MAX II device must reconfigure the target device.



For more information on configuration issues, see the *Debugging Configuration Problems* chapter of the *Configuration Handbook* and the FPGA Configuration Troubleshooter on the Altera web site (www.altera.com).

Multiple Device PS Configuration Using a MAX II Device as an External Host

Figure 13–10 shows how to configure multiple devices using a MAX II device. This circuit is similar to the PS configuration circuit for a single device, except Cyclone II devices are cascaded for multiple device configuration.

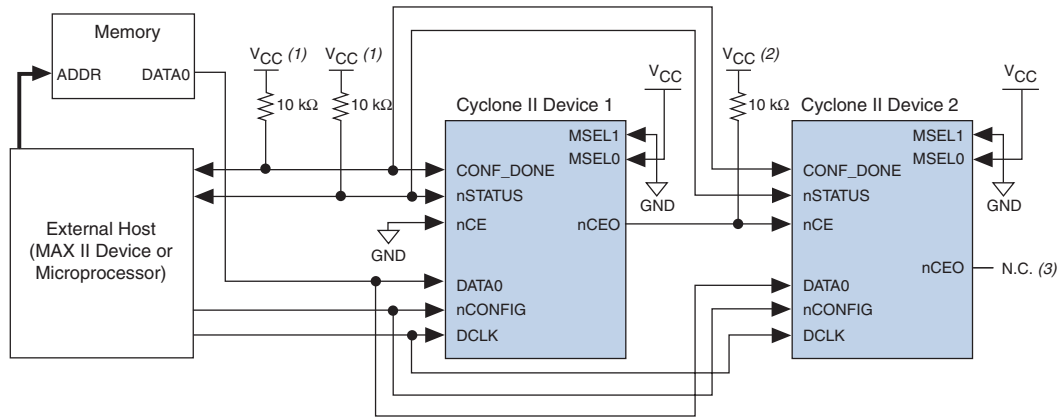
Figure 13–10. Multiple Device PS Configuration Using an External Host**Notes to Figure 13–10:**

- (1) The pull-up resistor should be connected to a supply that provides an acceptable input signal for all devices in the chain. V_{CC} should be high enough to meet the V_{IH} specification of the I/O on the devices and the external host.
- (2) Connect the pull-up resistor to the V_{CCIO} supply voltage of I/O bank that the $nCEO$ pin resides in.
- (3) The $nCEO$ pin can be left unconnected or used as a user I/O pin when it does not feed another device's nCE pin.

In multiple device PS configuration, connect the first Cyclone II device's nCE pin to GND and connect the $nCEO$ pin to the nCE pin of the next Cyclone II device in the chain. Use an external 10-k Ω pull-up resistor to pull the Cyclone II device's $nCEO$ pin high to its V_{CCIO} level to help the internal weak pull-up resistor when the $nCEO$ pin feeds next Cyclone II device's nCE pin. The input to the nCE pin of the last Cyclone II device in the chain comes from the previous Cyclone II device. After the first device completes configuration in a multiple device configuration chain, its $nCEO$ pin transitions low to activate the second device's nCE pin, which prompts the second device to begin configuration within one clock cycle. Therefore, the MAX II device begins to transfer data to the next Cyclone II device without interruption. The $nCEO$ pin is a dual-purpose pin in Cyclone II devices. You can leave the $nCEO$ pin of the last device unconnected or use it as a user I/O pin after configuration if the last device in chain is a Cyclone II device.



The Quartus II software sets the Cyclone II device $nCEO$ pin as a dedicated output by default. If the $nCEO$ pin feeds the next device's nCE pin, you must make sure that the $nCEO$ pin is not used as a user I/O after configuration. This software setting is in the **Dual-Purpose Pins** tab of the **Device & Pin Options** dialog box in Quartus II software.

You must connect all other configuration pins (`nCONFIG`, `nSTATUS`, `DCLK`, `DATA0`, and `CONF_DONE`) to every Cyclone II device in the chain. The configuration signals may require buffering to ensure signal integrity and prevent clock skew problems. You should buffer the `DCLK` and `DATA` lines for every fourth device. Because all device `CONF_DONE` pins are tied together, all devices initialize and enter user mode at the same time.

Since all `nSTATUS` and `CONF_DONE` pins are connected, if any Cyclone II device detects an error, configuration stops for the entire chain and the entire chain must be reconfigured. For example, if the first Cyclone II detects an error, it resets the chain by pulling its `nSTATUS` pin low. This behavior is similar to a single Cyclone II device detecting an error.

If the **Auto-restart configuration after error** option is turned on, the Cyclone II devices release their `nSTATUS` pins after a reset time-out period (maximum of 40 μ s). After all `nSTATUS` pins are released and pulled high, the MAX II device reconfigures the chain without pulsing `nCONFIG` low. If the **Auto-restart configuration after error** option is turned off, the MAX II device must generate a low-to-high transition (with a low pulse of at least 40 μ s) on `nCONFIG` to restart the configuration process.

If you want to delay the initialization of the devices in the chain, you can use the `CLKUSR` pin option. The `CLKUSR` pin allows you to control when your device enters user mode. This feature also allows you to control the order of when each device enters user mode by feeding a separate clock to each device's `CLKUSR` pin. By using the `CLKUSR` pins, you can choose any device in the multiple device chain to enter user mode first and have the other devices enter user mode at a later time.

Different device families may require a different number of initialization clock cycles. Therefore, if your multiple device chain consists of devices from different families, the devices may enter user mode at a slightly different time due to the different number of initialization clock cycles required. However, if the number of initialization clock cycles is similar across different device families or if the devices are from the same family, then the devices enter user mode at the same time. See the respective device family handbook for more information about the number of initialization clock cycles required.

If your system has multiple Cyclone II devices (in the same density and package) with the same configuration data, you can configure them in one configuration cycle by connecting all device's nCE pins to ground and connecting all the Cyclone II device's configuration pins ($nCONFIG$, $nSTATUS$, $DCLK$, $DATA0$, and $CONF_DONE$) together. You can also use the $nCEO$ pin as a user I/O pin after configuration. The configuration signals may require buffering to ensure signal integrity and prevent clock skew problems. Make sure the $DCLK$ and $DATA$ lines are buffered for every fourth device. All devices will start and complete configuration at the same time. Figure 13–11 shows multiple device PS configuration when both Cyclone II devices are receiving the same configuration data.

Figure 13–11. Multiple Device PS Configuration When Both FPGAs Receive the Same Data

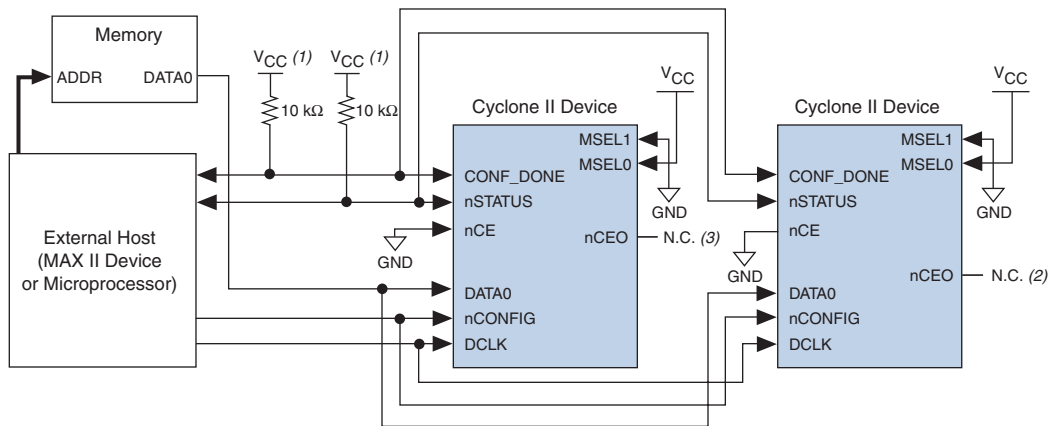

Notes to Figure 13–11:

- (1) The pull-up resistor should be connected to a supply that provides an acceptable input signal for all devices in the chain. V_{CC} should be high enough to meet the V_{IH} specification of the I/O on the devices and the external host.
- (2) The $nCEO$ pins of both devices can be left unconnected or used as user I/O pins when configuring the same configuration data into multiple devices.

You can use a single configuration chain to configure Cyclone II devices with other Altera devices. Connect all the Cyclone II device's and all other Altera device's $CONF_DONE$ and $nSTATUS$ pins together so all devices in the chain complete configuration at the same time or that an error reported by one device initiates reconfiguration in all devices.



For more information on configuring multiple Altera devices in the same configuration chain, see *Configuring Mixed Altera FPGA Chains* in the *Configuration Handbook*.

PS Configuration Timing

A PS configuration must meet the setup and hold timing parameters and the maximum clock frequency. When using a microprocessor or another intelligent host to control the PS interface, ensure that you meet these timing requirements.

Figure 13–12 shows the timing waveform for PS configuration for Cyclone II devices.

Figure 13–12. PS Configuration Timing Waveform Note (1)

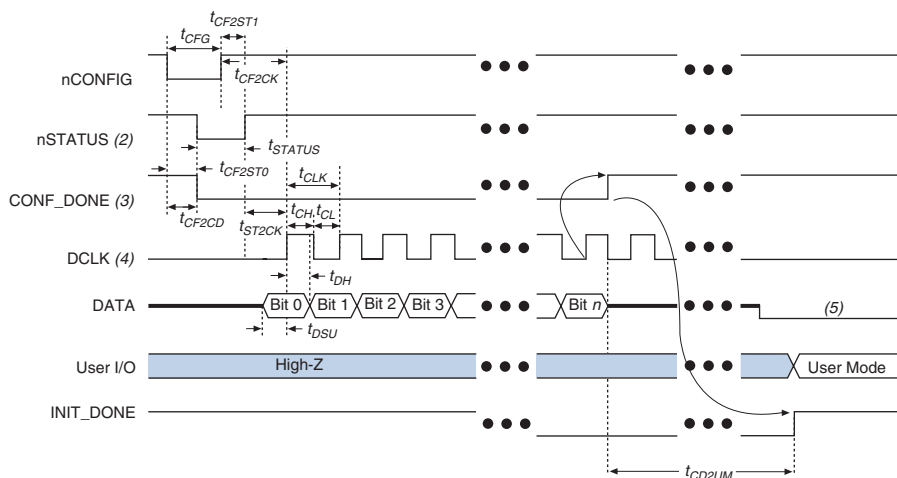

Notes to Figure 13–12:

- (1) The beginning of this waveform shows the device in user mode. In user mode, nCONFIG, nSTATUS and CONF_DONE are at logic high levels. When nCONFIG is pulled low, a reconfiguration cycle begins.
- (2) Upon power-up, the Cyclone II device holds nSTATUS low for the time of the POR delay.
- (3) Upon power-up, before and during configuration, CONF_DONE is low.
- (4) In user mode, drive DCLK either high or low when using the PS configuration scheme, whichever is more convenient. When using the AS configuration scheme, DCLK is a Cyclone II output pin and should not be driven externally.
- (5) Do not leave the DATA pin floating after configuration. Drive it high or low, whichever is more convenient.

Table 13–7 defines the timing parameters for Cyclone II devices for PS configuration.

Symbol	Parameter	Minimum	Maximum	Units
t_{POR}	POR delay		100	ms
t_{CF2CD}	nCONFIG low to CONF_DONE low		800	ns
t_{CF2ST0}	nCONFIG low to nSTATUS low		800	ns
t_{CFG}	nCONFIG low pulse width	40		μ s
t_{STATUS}	nSTATUS low pulse width	10	40 (2)	μ s
t_{CF2ST1}	nCONFIG high to nSTATUS high		40 (2)	μ s
t_{CF2CK}	nCONFIG high to first rising edge on DCLK	40		μ s
t_{ST2CK}	nSTATUS high to first rising edge of DCLK	1		μ s
t_{DSU}	Data setup time before rising edge on DCLK	7		ns
t_{DH}	Data hold time after rising edge on DCLK	0		ns
t_{CH}	DCLK high time	4		ns
t_{CL}	DCLK low time	4		ns
t_{CLK}	DCLK period	10		ns
f_{MAX}	DCLK frequency		100	MHz
t_{CD2UM}	CONF_DONE high to user mode (3)	18	40	μ s
t_{CD2CU}	CONF_DONE high to CLKUSR enabled	4 × maximum DCLK period		
t_{CD2UMC}	CONF_DONE high to user mode with CLKUSR option on	$t_{CD2CU} + (299 \times \text{CLKUSR period})$		

Notes to Table 13–7:

- (1) This information is preliminary.
- (2) This value is applicable if users do not delay configuration by extending the nCONFIG or nSTATUS low pulse width.
- (3) The minimum and maximum numbers apply only if the internal oscillator is chosen as the clock source for starting the device.



Device configuration options and how to create configuration files are discussed further in the *Software Settings* section in Volume 2 of the *Configuration Handbook*.

PS Configuration Using a Microprocessor

In the PS configuration scheme, a microprocessor can control the transfer of configuration data from a storage device, such as flash memory, to the target Cyclone II device.



All information in the “[Single Device PS Configuration Using a MAX II Device as an External Host](#)” on page 13–22 section is also applicable when using a microprocessor as an external host. Refer to that section for all configuration information.

The MicroBlaster™ software driver allows you to configure Altera FPGAs, including Cyclone II devices, through the ByteBlaster II or ByteBlasterMV cable in PS mode. The MicroBlaster software driver supports a RBF programming input file and is targeted for embedded PS configuration. The source code is developed for the Windows NT operating system, although you can customize it to run on other operating systems.



Since the Cyclone II device can decompress the compressed configuration data on-the-fly during PS configuration, the MicroBlaster software can accept a compressed RBF file as its input file.



For more information on the MicroBlaster software driver, see the *Configuring the MicroBlaster Passive Serial Software Driver White Paper* and source files on the Altera web site at www.altera.com.

If you turn on the **Enable user-supplied start-up clock (CLKUSR)** option in the Quartus II software, the Cyclone II devices will not enter user mode after the MicroBlaster has transmitted all the configuration data in the RBF file. You need to supply enough initialization clock cycles to CLKUSR pin to enter user mode.

Single Device PS Configuration Using a Configuration Device

You can use an Altera configuration device (for example, an EPC2, EPC1, or enhanced configuration device) to configure Cyclone II devices using a serial configuration bitstream. Configuration data is stored in the configuration device. [Figure 13–13](#) shows the configuration interface connections between the Cyclone II device and a configuration device.



The figures in this chapter only show the configuration-related pins and the configuration pin connections between the configuration device and the FPGA.



For more information on enhanced configuration devices and flash interface pins (e.g., PGM [2 . . 0], EXCLK, PORSEL, A [20 . . 0], and DQ [15 . . 0]), see the *Enhanced Configuration Devices (EPC4, EPC8 & EPC16) Data Sheet*.

Figure 13–13. Single Device PS Configuration Using an Enhanced Configuration Device

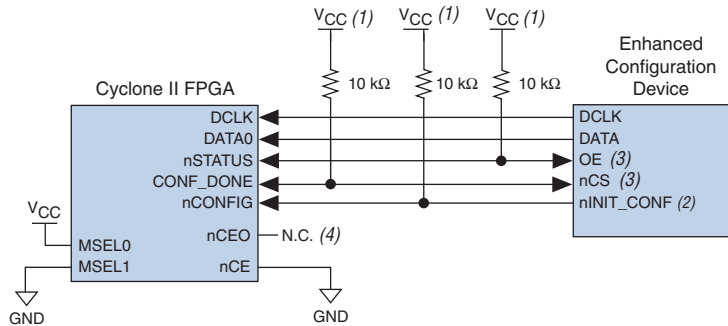

Notes to Figure 13–13:

- (1) The pull-up resistor should be connected to the same supply voltage as the configuration device. This pull-up resistor is 10 kΩ
- (2) The nINIT_CONF pin is available on enhanced configuration devices and has an internal pull-up resistor that is always active, meaning an external pull-up resistor should not be used on the nINIT_CONF to nCONFIG line. The nINIT_CONF pin does not need to be connected if its functionality is not used. If nINIT_CONF is not used, nCONFIG must be pulled to V_{CC} either directly or through a resistor.
- (3) The enhanced configuration devices' OE and nCS pins have internal programmable pull-up resistors. If internal pull-up resistors are used, external pull-up resistors should not be used on these pins. The internal pull-up resistors are used by default in the Quartus II software. To turn off the internal pull-up resistors, check the **Disable nCS and OE pull-ups on configuration device** option when generating programming files.
- (4) The nCEO pin can be left unconnected or used as a user I/O pin when it does not feed other device's nCE pin.



The value of the internal pull-up resistors on the enhanced configuration devices and EPC2 devices can be found in the *Enhanced Configuration Devices (EPC4, EPC8, & EPC16) Data Sheet* or the *Configuration Devices for SRAM-based LUT Devices Data Sheet*.

When using enhanced configuration devices or EPC2 devices, you can connect the Cyclone II nCONFIG pin to the configuration device nINIT_CONF pin, which allows the INIT_CONF JTAG instruction to initiate FPGA configuration. You do not need to connect the nINIT_CONF pin if you are not using it. If nINIT_CONF is not used or not available (e.g., on EPC1 devices), pull the nCONFIG signal to V_{CC} either directly or through a resistor. An internal pull-up resistor on the nINIT_CONF pin is always active in enhanced configuration devices and EPC2 devices. Therefore, you do not need an external pull-up if nCONFIG is connected to nINIT_CONF.

Upon power-up, the Cyclone II device goes through a POR. During POR, the device will reset, hold `nSTATUS` and `CONF_DONE` low, and tri-state all user I/O pins. After POR, which typically lasts 100 ms, the Cyclone II FPGA releases `nSTATUS` and enters configuration mode when this signal is pulled high by the external 10-k Ω resistor. Once the FPGA successfully exits POR, all user I/O pins continue to be tri-stated. Cyclone II devices have weak pull-up resistors on the user I/O pins which are on before and during configuration.

The configuration device also goes through a POR delay to allow the power supply to stabilize. The maximum POR time for EPC2 or EPC1 devices is 200 ms. The POR time for enhanced configuration devices can be set to 100 ms or 2 ms, depending on the enhanced configuration device's `PORSEL` pin setting. If the `PORSEL` pin is connected to ground, the POR delay is 100 ms. If the `PORSEL` pin is connected to V_{CC} , the POR delay is 2 ms. You must power the Cyclone II device before or during the enhanced configuration device POR time. During POR, the configuration device transitions its `OE` pin low. This low signal delays configuration because the `OE` pin is connected to the target device's `nSTATUS` pin. When the target and configuration devices complete POR, they both release the `nSTATUS` to `OE` line, which is then pulled high by a pull-up resistor.

When the power supplies have reached the appropriate operating voltages, the target FPGA senses the low-to-high transition on `nCONFIG` and initiates the configuration cycle. The configuration cycle consists of three stages: reset, configuration, and initialization.



The Cyclone II device does not have a `PORSEL` pin.

Reset Stage

While `nCONFIG` or `nSTATUS` is low, the device is in reset. You can delay configuration by holding the `nCONFIG` or `nSTATUS` pin low.



V_{CCINT} and V_{CCIO} of the banks where the configuration and JTAG pins reside need to be fully powered to the appropriate voltage levels in order to begin the configuration process.

When the `nCONFIG` signal goes high, the device comes out of reset and releases the `nSTATUS` pin, which is pulled high by a pull-up resistor. Enhanced configuration and EPC2 devices have an optional internal pull-up resistor on the `OE` pin. You can turn on this option in the Quartus II software from the **General** tab of the **Device & Pin Options** dialog box. If this internal pull-up resistor is not used, you need to connect an external 10-k Ω pull-up resistor to the `OE` and `nSTATUS` line. Once `nSTATUS` is released, the FPGA is ready to receive configuration data and the configuration stage begins.

Configuration Stage

When the `nSTATUS` pin transitions high, the configuration device's `OE` pin also transitions high and the configuration device clocks data out serially to the FPGA using its internal oscillator. The Cyclone II device receives configuration data on its `DATA0` pin and the clock is received on the `DCLK` pin. Data is latched into the FPGA on the rising edge of `DCLK`.

After the FPGA has received all configuration data successfully, it releases the open-drain `CONF_DONE` pin, which is pulled high by a pull-up resistor. Since the Cyclone II device's `CONF_DONE` pin is tied to the configuration device's `nCS` pin, the configuration device is disabled when `CONF_DONE` goes high. Enhanced configuration and EPC2 devices have an optional internal pull-up resistor on the `nCS` pin. You can turn this option on in the Quartus II software from the **General** tab of the **Device & Pin Options** dialog box. If you do not use this internal pull-up resistor, you need to connect an external 10-k Ω pull-up resistor to the `nCS` and `CONF_DONE` line. A low-to-high transition on `CONF_DONE` indicates configuration is complete, and the device can begin initialization.

Initialization Stage

In Cyclone II devices, the default initialization clock source is the Cyclone II internal oscillator (typically 10 MHz). Cyclone II devices can also use the optional `CLKUSR` pin. If your design uses the internal oscillator, the Cyclone II device will supply itself with enough clock cycles for proper initialization. The advantage of using the internal oscillator is you do not need to use another device or source to send additional clock cycles to the `CLKUSR` pin during the initialization stage. Additionally, you can use of the `CLKUSR` pin as a user I/O pin, which means you have an additional user I/O pin.

If you want to delay the initialization of the device, you can use the `CLKUSR` pin. Using the `CLKUSR` pin allows you to control when the Cyclone II device enters user mode. You can delay the Cyclone II devices from entering user mode for an indefinite amount of time. You can turn on the **Enable user-supplied start-up clock (CLKUSR)** option in the Quartus II software from the **General** tab of the **Device & Pin Options** dialog box. Supplying a clock on `CLKUSR` will not affect the configuration process. After all configuration data is accepted and `CONF_DONE` goes high, Cyclone II devices require 299 clock cycles to properly initialize and support a `CLKUSR` f_{MAX} of 100 MHz.

An optional `INIT_DONE` pin is available, which signals the end of initialization and the start of user mode with a low-to-high transition. The **Enable INIT_DONE output** option is available in the Quartus II software from the **General** tab of the **Device & Pin Options** dialog box. If you use the `INIT_DONE` pin, an external 10-k Ω pull-up resistor pulls it high when

nCONFIG is low and during the beginning of configuration. Once the optional bit to enable INIT_DONE is programmed into the device (during the first frame of configuration data), the INIT_DONE pin goes low. When initialization is complete, the INIT_DONE pin is released and pulled high. This low-to-high transition signals that the FPGA has entered user mode. If you do not use the INIT_DONE pin, the initialization period will be complete after the CONF_DONE signal transitions high and 299 clock cycles are sent to the CLKUSR pin or after the time t_{CF2UM} (see Table 13-7) if the Cyclone II device uses the internal oscillator.

After successful configuration, if you intend to synchronize the initialization of multiple devices that are not in the same configuration chain, your system must not pull the CONF_DONE signal low to delay initialization. Instead, use the optional CLKUSR pin to synchronize the initialization of multiple devices that are not in the same configuration chain. Devices in the same configuration chain will initialize together if their CONF_DONE pins are tied together.



If the optional CLKUSR pin is being used and nCONFIG is pulled low to restart configuration during device initialization, you need to ensure that CLKUSR continues toggling during the time nSTATUS is low (maximum of 40 μ s).

User Mode

When initialization is complete, the FPGA enters user mode. In user mode, the user I/O pins do not have weak pull-up resistors and will function as assigned in your design. Enhanced configuration devices and EPC2 devices drive DCLK low and DATA0 high (EPC1 devices drive the DCLK pin low and tri-state the DATA pin) at the end of configuration.

When the FPGA is in user mode, pull the nCONFIG pin low to begin reconfiguration. The nCONFIG pin should be low for at least 40 μ s. When nCONFIG transitions low, the Cyclone II device also pulls the nSTATUS and CONF_DONE pins low and all I/O pins are tri-stated. Since CONF_DONE transitions low, this will activate the configuration device since it will see its nCS pin transition low. Once nCONFIG returns to a logic high level and nSTATUS is released by the FPGA, reconfiguration begins.

Error During Configuration

If an error occurs during configuration, the Cyclone II drives its nSTATUS pin low, resetting itself internally. Since the nSTATUS pin is tied to OE, the configuration device will also be reset. If you turn on the **Auto-restart configuration after error** option in the Quartus II software from the **General** tab of the **Device & Pin Options** dialog box, the FPGA

automatically initiates reconfiguration if an error occurs. The Cyclone II device will release its `nSTATUS` pin after a reset time-out period (maximum of 40 μ s). When the `nSTATUS` pin is released and pulled high by a pull-up resistor, the configuration device reconfigures the chain. If this option is turned off, the external system must monitor `nSTATUS` for errors and then pulse `nCONFIG` low for at least 40 μ s to restart configuration. The external system can pulse the `nCONFIG` pin if the pin is under system control rather than tied to V_{CC} .

Additionally, if the configuration device sends all of its data and then detects that the `CONF_DONE` pin has not transitioned high, it recognizes that the FPGA has not configured successfully. Enhanced configuration devices wait for 64 `DCLK` cycles after the last configuration bit was sent for the `CONF_DONE` pin to transition high. EPC2 devices wait for 16 `DCLK` cycles. After that, the configuration device pulls its `OE` pin low, which in turn drives the target device's `nSTATUS` pin low. If you turn on the **Auto-restart configuration after error** option in the Quartus II software, the target device resets and then releases its `nSTATUS` pin after a reset time-out period (maximum of 40 μ s). When `nSTATUS` transitions high again, the configuration device reconfigures the FPGA.



For more information on configuration issues, see the *Debugging Configuration Problems* chapter of the *Configuration Handbook* and the FPGA Configuration Troubleshooter on the Altera web site (www.altera.com).

Multiple Device PS Configuration Using a Configuration Device

You can use Altera enhanced configuration devices (EPC16, EPC8, and EPC4 devices) or EPC2 and EPC1 configuration devices to configure multiple Cyclone II devices in a PS configuration chain.

Figure 13–14 shows how to configure multiple devices with an enhanced configuration device. This circuit is similar to the configuration device circuit for a single device, except Cyclone II devices are cascaded for multiple device configuration.

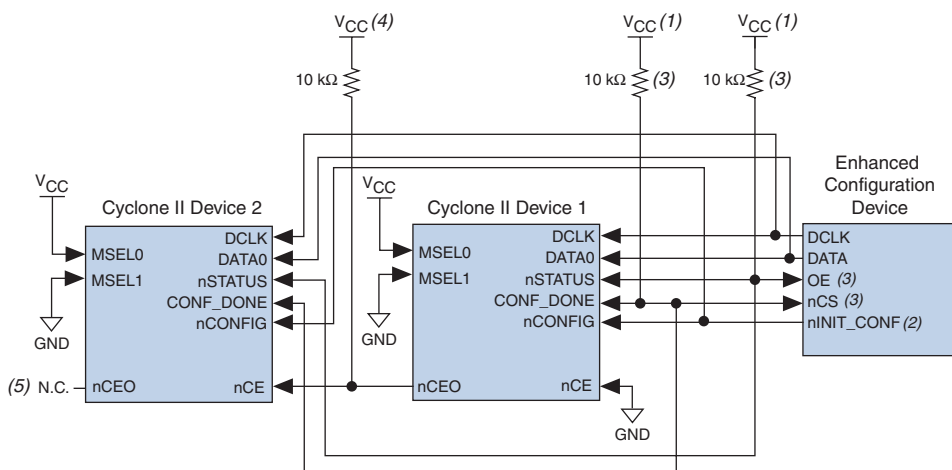
Figure 13–14. Multiple Device PS Configuration Using an Enhanced Configuration Device**Notes to Figure 13–14:**

- (1) The pull-up resistor should be connected to the same supply voltage as the configuration device.
- (2) The nINIT_CONF pin is available on enhanced configuration devices and has an internal pull-up resistor that is always active, meaning an external pull-up resistor should not be used on the nINIT_CONF to nCONFIG line. The nINIT_CONF pin does not need to be connected if its functionality is not used. If nINIT_CONF is not used, nCONFIG must be pulled to V_{CC} either directly or through a resistor.
- (3) The enhanced configuration devices' OE and nCS pins have internal programmable pull-up resistors. If internal pull-up resistors are used, external pull-up resistors should not be used on these pins. The internal pull-up resistors are used by default in the Quartus II software. To turn off the internal pull-up resistors, check the **Disable nCS and OE pull-ups on configuration device** option when generating programming files.
- (4) Connect the pull-up resistor to the V_{CCIO} supply voltage of I/O bank that the nCEO pin resides in.
- (5) The nCEO pin can be left unconnected or used as a user I/O pin when it does not feed other device's nCE pin.



You cannot cascade enhanced configuration devices (EPC16, EPC8, and EPC4 devices).

When configuring multiple devices, you must generate the configuration device's POF from each project's SOF. You can combine multiple SOFs using the **Convert Programming Files** window in the Quartus II software.



For more information on how to create configuration files for multiple device configuration chains, see the *Software Settings* section in Volume 2 of the *Configuration Handbook*.

When configuring multiple devices with the PS scheme, connect the first Cyclone II device's nCE pin to GND and connect its nCEO pin to the nCE pin of the Cyclone II device in the chain. Use an external 10-kΩ pull-up resistor to pull the Cyclone II device's nCEO pin to the V_{CCIO} level when

it feeds the next device's `nCE` pin. After the first device in the chain completes configuration, its `nCEO` pin transitions low to activate the second device's `nCE` pin, which prompts the second device to begin configuration. You can leave the `nCEO` pin of the last device unconnected or use it as a user I/O pin after configuration. The `nCEO` pin is a dual-purpose pin in Cyclone II devices.



The Quartus II software sets the Cyclone II device `nCEO` pin as an output pin driving to ground by default. If the device is in a chain, and the `nCEO` pin is connected to the next device's `nCE` pin, you must make sure that the `nCEO` pin is not used as a user I/O pin after configuration. This software setting is in the **Dual-Purpose Pins** tab of the **Device & Pin Options** dialog box in Quartus II software.

Connect all other configuration pins (`nCONFIG`, `nSTATUS`, `DCLK`, `DATA0`, and `CONF_DONE`) to every Cyclone II device in the chain. The configuration signals may require buffering to ensure signal integrity and prevent clock skew problems. Buffer the `DCLK` and `DATA` lines for every fourth device.

When configuring multiple devices, configuration does not begin until all devices release their `OE` or `nSTATUS` pins. Similarly, since all device `CONF_DONE` pins are tied together, all devices initialize and enter user mode at the same time.

You should not pull `CONF_DONE` low to delay initialization. Instead, use the Quartus II software's **User-Supplied Start-Up Clock** option to synchronize the initialization of multiple devices that are not in the same configuration chain. Devices in the same configuration chain initialize together since their `CONF_DONE` pins are tied together.

Since all `nSTATUS` and `CONF_DONE` pins are connected, if any device detects an error, configuration stops for the entire chain and the entire chain must be reconfigured. For example, if there is an error when configuring the first Cyclone II device, it resets the chain by pulling its `nSTATUS` pin low. This low signal drives the `OE` pin low on the enhanced configuration device and drives `nSTATUS` low on all FPGAs, which causes them to enter a reset state.

If the **Auto-restart configuration after error** option is turned on, the devices will automatically initiate reconfiguration if an error occurs. The FPGAs will release their `nSTATUS` pins after a reset time-out period (40 μ s maximum). When all the `nSTATUS` pins are released and pulled high, the configuration device reconfigures the chain. If the **Auto-restart configuration after error** option is turned off, a microprocessor or controller must monitor the `nSTATUS` pin for errors and then pulse

nCONFIG low for at least 40 μ s to restart configuration. The microprocessor or controller can only transition the nCONFIG pin low if the pin is under system control and not tied to V_{CC} .

The enhanced configuration devices support parallel configuration of up to eight devices. The n -bit ($n = 1, 2, 4, \text{ or } 8$) PS configuration mode allows enhanced configuration devices to concurrently configure a chain of FPGAs. These devices do not have to be the same device family or density; they can be any combination of Altera FPGAs with different designs. An individual enhanced configuration device DATA pin is available for each targeted FPGA. Each DATA line can also feed a chain of FPGAs. [Figure 13–15](#) shows how to concurrently configure multiple devices using an enhanced configuration device.

DATA3, you can leave the corresponding bit 3 line blank in the Quartus II software. On the printed circuit board (PCB), leave the DATA3 line from the enhanced configuration device unconnected. Use the Quartus II **Convert Programming Files** window (Tools menu) setup for this scheme.

You can also connect two FPGAs to one of the configuration device's DATA pins while the other DATA pins drive one device each. For example, you could use the 2-bit PS mode to drive two FPGAs with DATA bit 0 (two EP2C5 devices) and the third device (an EP2C8 device) with DATA bit 1. In this example, the memory space required for DATA bit 0 is the sum of the SOF file size for the two EP2C5 devices.

$$1,223,980 \text{ bits} + 1,223,980 \text{ bits} = 2,447,960 \text{ bits}$$

The memory space required for DATA bit 1 is the SOF file size for an EP2C8 device (1,983,792 bits). Since the memory space required for DATA bit 0 is larger than the memory space required for DATA bit 1, the size of the POF file is $2 \times 2,447,960 = 4,895,920$.



For more information on using n -bit PS modes with enhanced configuration devices, see the *Using Altera Enhanced Configuration Devices* in the *Configuration Handbook*.

When configuring SRAM-based devices using n -bit PS modes, use [Table 13–8](#) to select the appropriate configuration mode for the fastest configuration times.

Number of Devices (1)	Recommended Configuration Mode
1	1-bit PS
2	2-bit PS
3	4-bit PS
4	4-bit PS
5	8-bit PS
6	8-bit PS
7	8-bit PS
8	8-bit PS

Note to Table 13–8:

- (1) Assume that each DATA line is only configuring one device, not a daisy chain of devices.

If your design has multiple Cyclone II devices of the same density and package that contain the same configuration data, connect the `nCE` inputs to GND and leave the `nCEO` pins floating. You can also use the `nCEO` pin as a user I/O pin. Connect the configuration device `nCONFIG`, `nSTATUS`, `DCLK`, `DATA0`, and `CONF_DONE` pins to each Cyclone II device in the chain. The configuration signals may require buffering to ensure signal integrity and prevent clock skew problems. Make sure that the `DCLK` and `DATA` lines are buffered for every fourth device. All devices will start and complete configuration at the same time. [Figure 13–16](#) shows multiple device PS configuration when the Cyclone II devices are receiving the same configuration data.

devices and to the slave configuration devices. Connect the first configuration device's `nCS` pin to all the Cyclone II device's `CONF_DONE` pins, and connect the `nCASC` pin to the `nCS` pin of the next configuration device in the chain. Leave the `nCASC` pin of the last configuration device floating. When the master configuration device sends all the data to the Cyclone II device, the configuration device transitions the `nCASC` pin low, which drives `nCS` on the next configuration device. Because a configuration device requires less than one clock cycle to activate a subsequent configuration device, the data stream is uninterrupted.



Enhanced configuration devices (EPC16, EPC8, and EPC4 devices) cannot be cascaded.

Since all `nSTATUS` and `CONF_DONE` pins are connected, if any device detects an error, the master configuration device stops configuration for the entire chain and the entire chain must be reconfigured. For example, if the master configuration device does not detect the Cyclone II device's `CONF_DONE` pin transitioning high at the end of configuration, it resets the entire chain by transitioning its `OE` pin low. This low signal drives the `OE` pin low on the slave configuration device(s) and drives `nSTATUS` low on all Cyclone II devices, causing them to enter a reset state. This behavior is similar to the FPGA detecting an error in the configuration data.

Figure 13–17 shows how to configure multiple devices using cascaded EPC2 or EPC1 devices.

You can use a single configuration chain to configure Cyclone II devices with other Altera devices. To ensure that all devices in the chain complete configuration at the same time or that an error flagged by one device initiates reconfiguration in all devices, connect all the Cyclone II device CONF_DONE pins and connect all Cyclone II device nSTATUS pins together.



For more information on configuring multiple Altera devices in the same configuration chain, see the *Configuring Mixed Altera FPGA Chains* chapter in the *Configuration Handbook*.

During PS configuration, the design must meet the setup and hold timing parameters and maximum DCLK frequency. The enhanced configuration and EPC2 devices are designed to meet these interface timing specifications.

Figure 13–18 shows the timing waveform for the PS configuration scheme using a configuration device.

Figure 13–18. Cyclone II PS Configuration Using a Configuration Device Timing Waveform

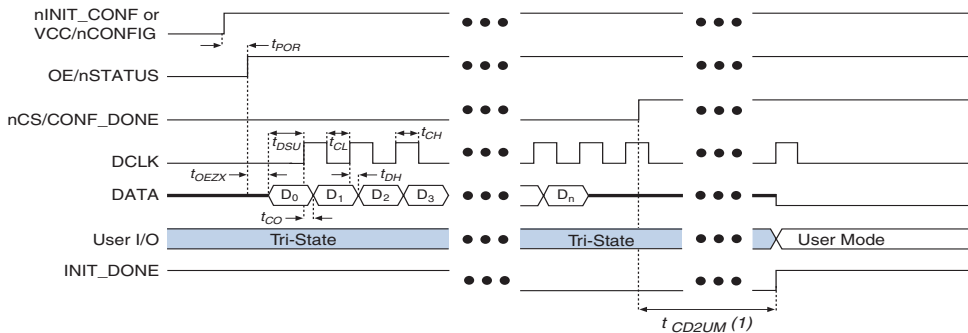

Note to Figure 13–18:

- (1) Cyclone II devices enter user mode 299 clock cycles after CONF_DONE goes high. The initialization clock can come from the Cyclone II internal oscillator or the CLKUSR pin.



For timing information, refer to the *Enhanced Configuration Devices (EPC4, EPC8, and EPC16) Data Sheet* or the *Configuration Devices for SRAM-based LUT Devices Data Sheet* in the *Configuration Handbook*.



For more information on device configuration options and how to create configuration files, see the *Software Settings* section in Volume 2 of the *Configuration Handbook*.

PS Configuration Using a Download Cable

In PS configuration, an intelligent host (e.g., a PC) can use a download cable to transfer data from a storage device to the Cyclone II device. You can use the Altera USB-Blaster universal serial bus (USB) port download cable, MasterBlaster™ serial/USB communications cable, ByteBlaster II parallel port download cable, or the ByteBlasterMV™ parallel port as a download cable.

Upon power up, the Cyclone II device goes through POR, which lasts approximately 100 ms. During POR, the device will reset, hold `nSTATUS` low, and tri-state all user I/O pins. Once the FPGA successfully exits POR, the `nSTATUS` pin is released and all user I/O pins continue to be tri-stated.



The value of the weak pull-up resistors on the I/O pins that are on before and during configuration can be found in the *Cyclone II Device Handbook*.

The configuration cycle consists of three stages: reset, configuration, and initialization. While the `nCONFIG` or `nSTATUS` pins are low, the device is in reset. To initiate configuration in this scheme, the download cable generates a low-to-high transition on the `nCONFIG` pin.



Make sure V_{CCINT} and V_{CCIO} for the banks where the configuration and JTAG pins reside are powered to the appropriate voltage levels in order to begin the configuration process.

When `nCONFIG` transitions high, the Cyclone II device comes out of reset and begins configuration. The Cyclone II device releases the open-drain `nSTATUS` pin, which is then pulled high by an external 10-k Ω pull-up resistor. Once `nSTATUS` transitions high, the Cyclone II device is ready to receive configuration data. The programming hardware or download cable then transmits the configuration data one bit at a time to the device's `DATA0` pin. The configuration data is clocked into the target device until `CONF_DONE` goes high.

When using a download cable, you cannot use the **Auto-restart configuration after error** option. You must manually restart configuration in the Quartus II software when an error occurs. Additionally, you cannot use the **Enable user-supplied start-up clock (CLKUSR)** option when programming the FPGA using the Quartus II programmer and download cable. This option is disabled in the SOF. Therefore, if you turn on the `CLKUSR` option, you do not need to provide a clock on `CLKUSR` when you are configuring the FPGA with the

Quartus II programmer and a download cable. Figure 13–19 shows the PS configuration for Cyclone II devices using a USB-Blaster, MasterBlaster, ByteBlaster II or ByteBlasterMV cable.

Figure 13–19. PS Configuration Using a USB-Blaster, MasterBlaster, ByteBlaster II or ByteBlasterMV Cable

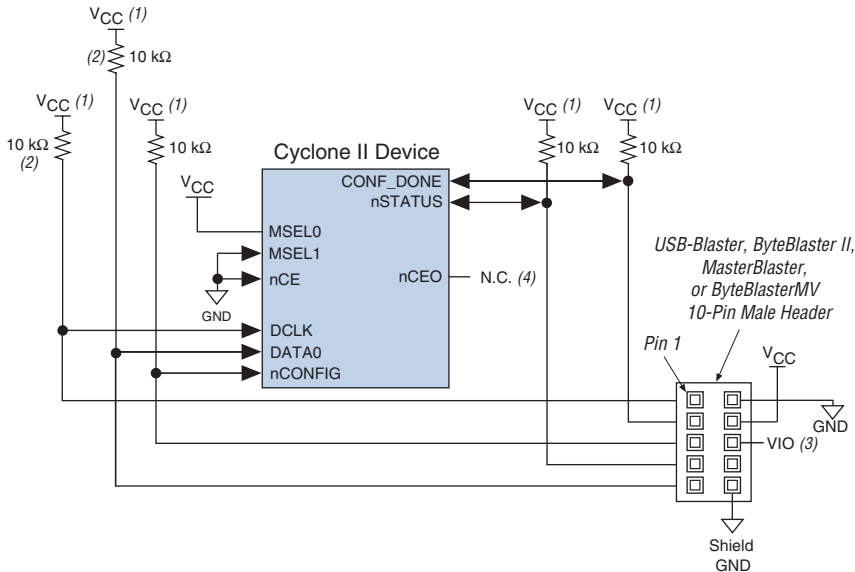

Notes to Figure 13–19:

- (1) The pull-up resistor should be connected to the same supply voltage as the USB-Blaster, MasterBlaster (VIO pin), ByteBlaster II, or ByteBlasterMV cable.
- (2) The pull-up resistors on DATA0 and DCLK are only needed if the download cable is the only configuration scheme used on your board. This is to ensure that DATA0 and DCLK are not left floating after configuration. For example, if you are also using a configuration device, the pull-up resistors on DATA0 and DCLK are not needed.
- (3) Pin 6 of the header is a VIO reference voltage for the MasterBlaster output driver. VIO should match the device's VCCIO. Refer to the *MasterBlaster Serial/USB Communications Cable Data Sheet* for this value. In the ByteBlasterMV, this pin is a no connect. In the USB-Blaster and ByteBlaster II, this pin is connected to nCE when it is used for AS programming, otherwise it is a no connect.
- (4) The nCEO pin can be left unconnected or used as a user I/O pin when it does not feed other device's nCE pin.

You can use a download cable to configure multiple Cyclone II devices by connecting each device's nCEO pin to the subsequent device's nCE pin. Connect the first Cyclone II device's nCEO pin to GND and connect its nCEO pin to the nCE pin of the next device in the chain. Use an external 10-kΩ pull-up resistor to pull the nCEO pin high to VCCIO when it feeds next device's nCE pin. Connect all other configuration pins (nCONFIG, nSTATUS, DCLK, DATA0, and CONF_DONE) on every device in the chain together. Because all CONF_DONE pins are connected, all devices in the chain initialize and enter user mode at the same time.

In addition, because the `nSTATUS` pins are connected, all the Cyclone II devices in the chain stop configuration if any device detects an error. If this happens, you must manually restart configuration in the Quartus II software.

Figure 13–20 shows how to configure multiple Cyclone II devices with a download cable.

Figure 13–20. Multiple Device PS Configuration Using a USB-Blaster, MasterBlaster, ByteBlaster II or ByteBlasterMV Cable

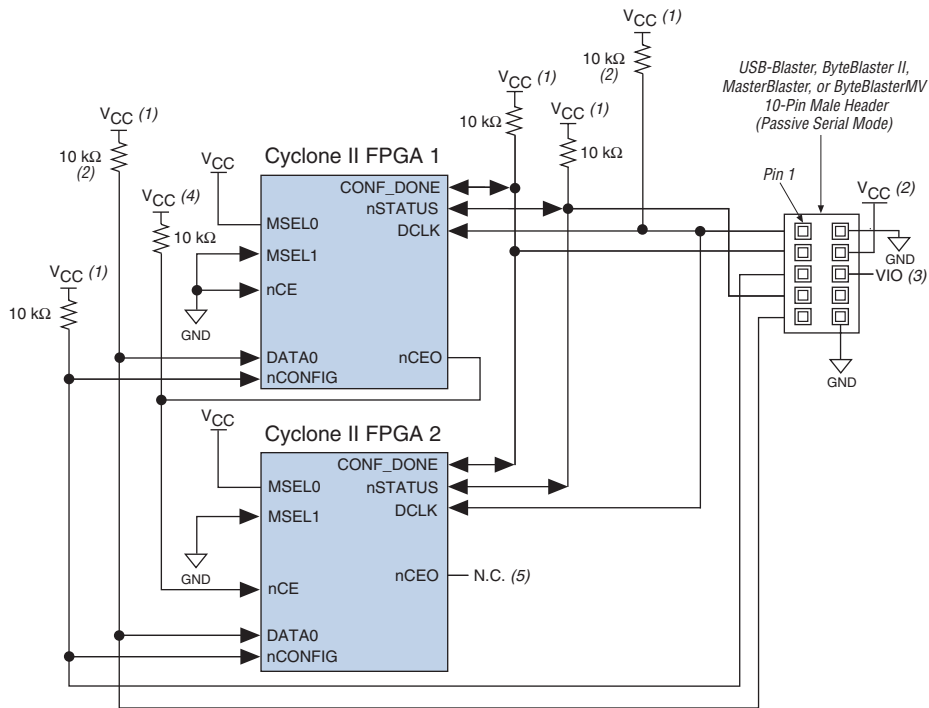

Notes to Figure 13–20:

- (1) The pull-up resistor should be connected to the same supply voltage as the USB-Blaster, MasterBlaster (VIO pin), ByteBlaster II, or ByteBlasterMV cable.
- (2) The pull-up resistors on DATA0 and DCLK are only needed if the download cable is the only configuration scheme used on your board. This is to ensure that DATA0 and DCLK are not left floating after configuration. For example, if you are also using a configuration device, the pull-up resistors on DATA0 and DCLK are not needed.
- (3) Pin 6 of the header is a VIO reference voltage for the MasterBlaster output driver. VIO should match the device's VCCIO. Refer to the MasterBlaster Serial/USB Communications Cable Data Sheet for this value. In the ByteBlasterMV, this pin is a no connect. In the USB-Blaster and ByteBlaster II, this pin is connected to nCE when it is used for AS programming, otherwise it is a no connect.
- (4) Connect the pull-up resistor to the VCCIO supply voltage of I/O bank that the nCEO pin resides in.
- (5) The nCEO pin of the last device in chain can be left unconnected or used as a user I/O pin.

If you are using a download cable to configure Cyclone II devices on a PCB that also has configuration devices, you should electrically isolate the configuration devices from the target Cyclone II devices and cable. One way to isolate the configuration device is to add logic, such as a multiplexer, that can select between the configuration device and the cable. The multiplexer should allow bidirectional transfers on the nSTATUS and CONF_DONE signals. Additionally, you can add switches to

the five common signals (nCONFIG, nSTATUS, DCLK, DATA0, and CONF_DONE) between the cable and the configuration device. You can also remove the configuration device from the board when configuring the FPGA with the cable. Figure 13–21 shows a combination of a configuration device and a download cable to configure an FPGA.

Figure 13–21. PS Configuration with a Download Cable & Configuration Device Circuit

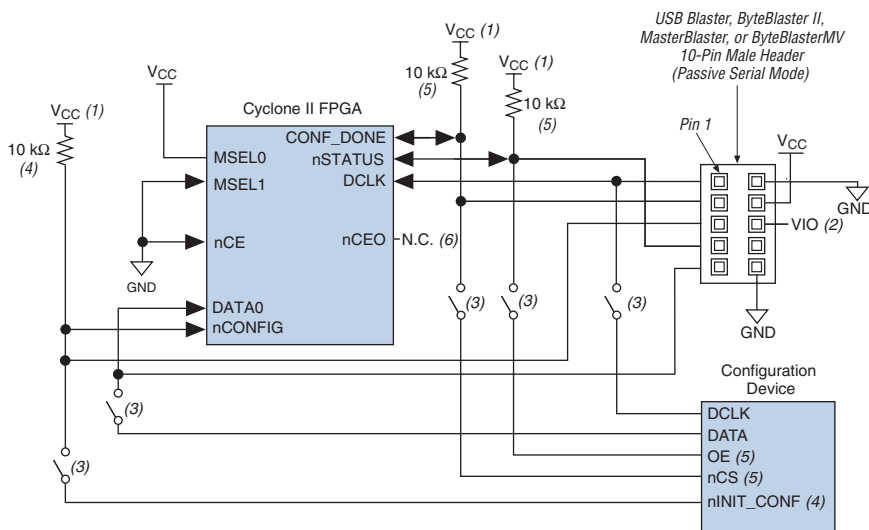

Notes to Figure 13–21:

- (1) The pull-up resistor should be connected to the same supply voltage as the configuration device.
- (2) Pin 6 of the header is a V_{IO} reference voltage for the MasterBlaster output driver. V_{IO} should match the device's V_{CCIO} . Refer to the *MasterBlaster Serial/USB Communications Cable Data Sheet* for this value. In the ByteBlasterMV, this pin is a no connect. In the USB-Blaster and ByteBlaster II, this pin is connected to nCE when it is used for AS programming, otherwise it is a no connect.
- (3) You should not attempt configuration with a download cable while a configuration device is connected to a Cyclone II device. Instead, you should either remove the configuration device from its socket when using the download cable or place a switch on the five common signals between the download cable and the configuration device.
- (4) The nINIT_CONF pin (available on enhanced configuration devices and EPC2 devices only) has an internal pull-up resistor that is always active. This means an external pull-up resistor should not be used on the nINIT_CONF to nCONFIG line. The nINIT_CONF pin does not need to be connected if its functionality is not used. If nINIT_CONF is not used or not available (e.g., on EPC1 devices), nCONFIG must be pulled to V_{CC} either directly or through a resistor.
- (5) The enhanced configuration devices' OE and nCS pins have internal programmable pull-up resistors. If internal pull-up resistors are used, external pull-up resistors should not be used on these pins. The internal pull-up resistors are used by default in the Quartus II software. To turn off the internal pull-up resistors, check the **Disable nCS and OE pull-ups on configuration device** option when generating programming files.
- (6) The nCEO pin can be left unconnected or used as a user I/O pin when it does not feed other device's nCE pin.



For more information on how to use the USB-Blaster, MasterBlaster, ByteBlaster II or ByteBlasterMV cables, refer to the following documents:

- *USB-Blaster USB Port Download Cable Data Sheet*
- *MasterBlaster Serial/USB Communications Cable Data Sheet*
- *ByteBlaster II Parallel Port Download Cable Data Sheet*
- *ByteBlasterMV Parallel Port Download Cable Data Sheet*

JTAG Configuration

The Joint Test Action Group (JTAG) has developed a specification for boundary-scan testing. This boundary-scan test (BST) architecture allows you to test components on PCBs with tight lead spacing. The BST architecture can test pin connections without using physical test probes and capture functional data while a device is operating normally. The JTAG circuitry can also be used to shift configuration data into the device. The Quartus II software automatically generates SOF files that can be used for JTAG configuration with a download cable in the Quartus II programmer.



For more information on JTAG boundary-scan testing, see the following documents:

- *IEEE 1149.1 (JTAG) Boundary-Scan Testing for Cyclone II Devices* chapter in Volume 2 of the *Cyclone II Device Handbook*
- *Jam Programming & Testing Language Specification*

Cyclone II devices are designed such that JTAG instructions have precedence over any device configuration modes. This means that JTAG configuration can take place without waiting for other configuration modes to complete. For example, if you attempt JTAG configuration of Cyclone II devices during PS configuration, PS configuration will terminate and JTAG configuration will begin. If the Cyclone II MSEL pins are set to AS or fast AS mode, the Cyclone II device will not output a DCLK signal when JTAG configuration takes place.



You cannot use the Cyclone II decompression feature if you are configuring your Cyclone II device when using JTAG-based configuration.

A device operating in JTAG mode uses the TDI, TDO, TMS, and TCK pins. The TCK pin has a weak internal pull-down resistor while the other JTAG input pins, TDI and TMS, have weak internal pull-up resistors. All user I/O pins are tri-stated during JTAG configuration. Table 13–9 explains each JTAG pin's function.

Table 13–9. Dedicated JTAG Pins

Pin Name	Pin Type	Description
TDI	Test data input	Serial input pin for instructions as well as test and programming data. Data is shifted in on the rising edge of TCK. If the JTAG interface is not required on the board, the JTAG circuitry can be disabled by connecting this pin to V _{CC} .
TDO	Test data output	Serial data output pin for instructions as well as test and programming data. Data is shifted out on the falling edge of TCK. The pin is tri-stated if data is not being shifted out of the device. If the JTAG interface is not required on the board, the JTAG circuitry can be disabled by leaving this pin unconnected.
TMS	Test mode select	Input pin that provides the control signal to determine the transitions of the TAP controller state machine. Transitions within the state machine occur on the rising edge of TCK. Therefore, TMS must be set up before the rising edge of TCK. TMS is evaluated on the rising edge of TCK. If the JTAG interface is not required on the board, the JTAG circuitry can be disabled by connecting this pin to V _{CC} .
TCK	Test clock input	The clock input to the BST circuitry. Some operations occur at the rising edge, while others occur at the falling edge. If the JTAG interface is not required on the board, the JTAG circuitry can be disabled by connecting this pin to GND.



The TDO output is powered by the V_{CCIO} power supply. If V_{CCIO} is tied to 3.3-V, both the I/O pins and the JTAG TDO port drive at 3.3-V levels.

Single Device JTAG Configuration

During JTAG configuration, you can use the USB-Blaster, MasterBlaster, ByteBlaster II, or ByteBlasterMV download cable to download data to the device. Configuring Cyclone II devices through a cable is similar to programming devices in system. Figure 13–22 shows JTAG configuration of a single Cyclone II device using a download cable.

Figure 13–22. JTAG Configuration of a Single Device Using a Download Cable

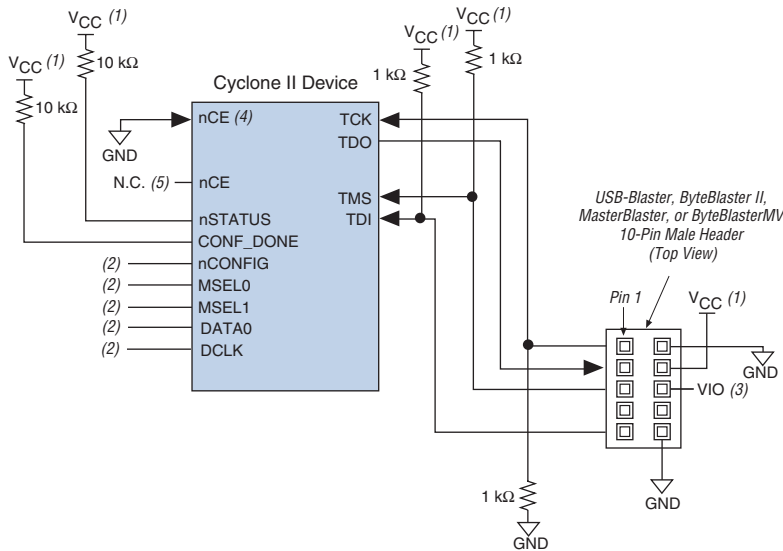

Notes to Figure 13–22:

- (1) The pull-up resistor should be connected to the same supply voltage as the USB-Blaster, MasterBlaster (V_{IO} pin), ByteBlaster II, or ByteBlasterMV cable.
- (2) Connect the nCONFIG and MSEL[1..0] pins to support a non-JTAG configuration scheme. If only JTAG configuration is used, connect the nCONFIG pin to V_{CC}, and the MSEL[1..0] pins to ground. In addition, pull DCLK and DATA0 to either high or low, whichever is convenient on your board.
- (3) Pin 6 of the header is a V_{IO} reference voltage for the MasterBlaster output driver. V_{IO} should match the device's V_{CCIO}. Refer to the *MasterBlaster Serial/USB Communications Cable Data Sheet* for this value. In the ByteBlasterMV, this pin is a no connect. In the USB-Blaster and ByteBlaster II, this pin is connected to nCE when it is used for AS programming, otherwise it is a no connect.
- (4) nCE must be connected to GND or driven low for successful JTAG configuration.
- (5) The nCEO pin can be left unconnected or used as a user I/O pin when it does not feed other device's nCE pin.

To configure a single device in a JTAG chain, the programming software places all other devices in BYPASS mode. In BYPASS mode, Cyclone II devices pass programming data from the TDI pin to the TDO pin through a single bypass register without being affected internally. This scheme

enables the programming software to program or verify the target device. Configuration data driven into the target device appears on the TDO pin one clock cycle later.

The Quartus II software verifies successful JTAG configuration upon completion. At the end of configuration, the software checks the CONF_DONE pin through the JTAG port. When the Quartus II software generates a JAM file for a multiple device chain, it contains instructions so that all the devices in the chain will be initialized at the same time. If CONF_DONE is not high, the Quartus II software indicates that configuration has failed. If the CONF_DONE pin transitions high, the software indicates that configuration was successful. After the configuration bitstream is transmitted serially via the JTAG TDI port, the TCK port is clocked an additional 299 cycles to perform Cyclone II device initialization.

The **Enable user-supplied start-up clock (CLKUSR)** option has no effect on the device initialization since this option is disabled in the SOF when configuring the FPGA in JTAG using the Quartus II programmer and download cable. Therefore, if you turn on the CLKUSR option, you do not need to provide a clock on CLKUSR when you are configuring the FPGA with the Quartus II programmer and a download cable.

Cyclone II devices have dedicated JTAG pins that always function as JTAG pins. You can perform JTAG testing on Cyclone II devices before, after, and during configuration. Cyclone II devices support the BYPASS, IDCODE and SAMPLE instructions during configuration without interruption. All other JTAG instructions may only be issued by first interrupting configuration and reprogramming I/O pins using the CONFIG_IO instruction.

The CONFIG_IO instruction allows I/O buffers to be configured via the JTAG port. The CONFIG_IO instruction will interrupt configuration. This instruction allows you to perform board-level testing before configuring the Cyclone II device or waiting for a configuration device to complete configuration. If you interrupt configuration, the Cyclone II device must be reconfigured via JTAG (PULSE_CONFIG instruction) or by pulsing nCONFIG low after JTAG testing is complete.



For more information, see the *MorphIO: An I/O Reconfiguration Solution for Altera White Paper*.

The chip-wide reset (DEV_CLRn) and chip-wide output enable (DEV_OE) pins on Cyclone II devices do not affect JTAG boundary-scan or programming operations. Toggling these pins will not affect JTAG operations (other than the usual boundary-scan operation).

When designing a Cyclone II board for JTAG configuration, use the guidelines in [Table 13–10](#) for the placement of the dedicated configuration pins.

Signal	Description
nCE	On all Cyclone II devices in the chain, nCE should be driven low by connecting it to ground, pulling it low via a resistor, or driving it by some control circuitry. For devices that are also in multiple device AS, or PS configuration chains, the nCE pins should be connected to GND during JTAG configuration or JTAG configured in the same order as the configuration chain.
nCEO	On all Cyclone II devices in the chain, nCEO can be used as a user I/O or connected to the nCE of the next device. If nCEO is connected to the nCE of the next device, the nCEO pin must be pulled high to V_{CCIO} by an external 10-k Ω pull-up resistor to help the internal weak pull-up resistor. If the nCEO pin is not connected to the nCE pin of the next device, you can use it as a user I/O pin after configuration.
MSEL	These pins must not be left floating. These pins support whichever non-JTAG configuration is used in production. If only JTAG configuration is used, you should tie these pins to ground.
nCONFIG	Driven high by connecting to V_{CC} , pulling up via a resistor, or driven high by some control circuitry.
nSTATUS	Pull to V_{CC} via a 10-k Ω resistor. When configuring multiple devices in the same JTAG chain, each nSTATUS pin should be pulled up to V_{CC} individually. nSTATUS pulling low in the middle of JTAG configuration indicates that an error has occurred.
CONF_DONE	Pull to V_{CC} via a 10-k Ω resistor. When configuring multiple devices in the same JTAG chain, each CONF_DONE pin should be pulled up to V_{CC} individually. CONF_DONE going high at the end of JTAG configuration indicates successful configuration.
DCLK	Should not be left floating. Drive low or high, whichever is more convenient on your board.

[Figure 13–23](#) shows JTAG configuration of a Cyclone II device with a microprocessor.

Figure 13–23. JTAG Configuration of a Single Device Using a Microprocessor

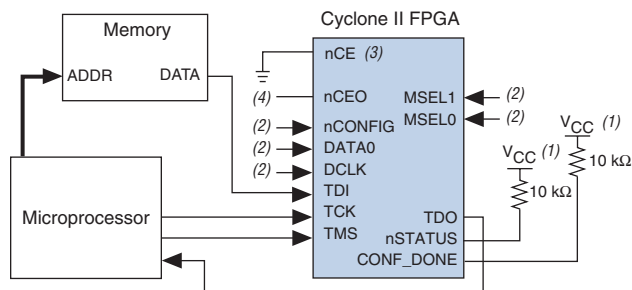

Notes to Figure 13–23:

- (1) The pull-up resistor should be connected to a supply that provides an acceptable input signal for all devices in the chain.
- (2) Connect the nCONFIG and MSEL [1 . . 0] pins to support a non-JTAG configuration scheme. If only JTAG configuration is used, connect the nCONFIG pin to V_{CC}, and the MSEL [1 . . 0] pins to ground. In addition, pull DCLK and DATA0 to either high or low, whichever is convenient on your board.
- (3) nCE must be connected to GND or driven low for successful JTAG configuration.
- (4) If using an EPCS4 or EPCS1 device, set MSEL [1 . . 0] to 00. See Table 13–4 for more details.

JTAG Configuration of Multiple Devices

When programming a JTAG device chain, one JTAG-compatible header is connected to several devices. The number of devices in the JTAG chain is limited only by the drive capability of the download cable. When four or more devices are connected in a JTAG chain, Altera recommends buffering the TCK, TDI, and TMS pins with an on-board buffer.

JTAG-chain device programming is ideal when the system contains multiple devices, or when testing your system using JTAG BST circuitry. Figure 13–24 shows multiple device JTAG configuration.

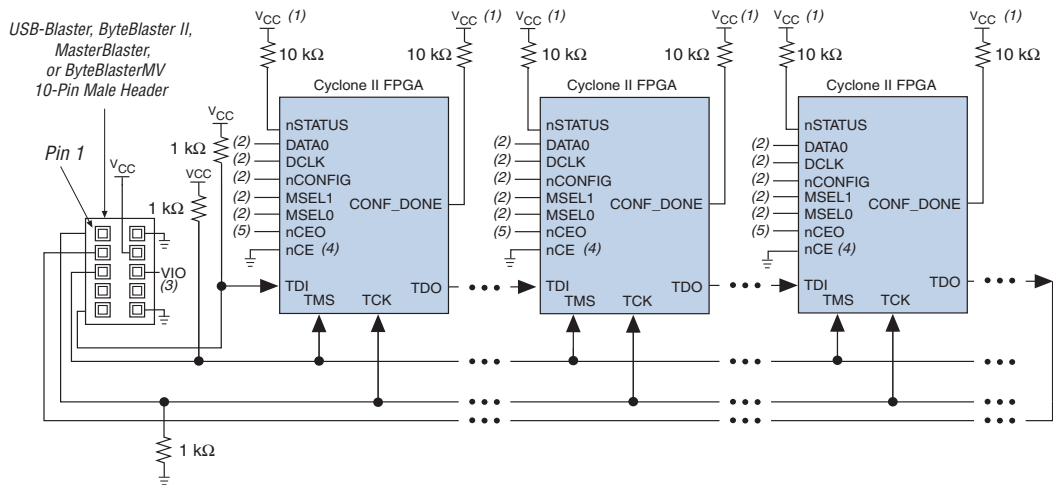
Figure 13–24. JTAG Configuration of Multiple Devices Using a Download Cable**Notes to Figure 13–24:**

- (1) The pull-up resistor should be connected to the same supply voltage as the USB-Blaster, MasterBlaster (VIO pin), ByteBlaster II or ByteBlasterMV cable.
- (2) Connect the nCONFIG and MSEL[1..0] pins to support a non-JTAG configuration scheme. If only JTAG configuration is used, connect the nCONFIG pin to V_{CC}, and the MSEL[1..0] pins to ground. In addition, pull DCLK and DATA0 to either high or low, whichever is convenient on your board.
- (3) Pin 6 of the header is a V_{IO} reference voltage for the MasterBlaster output driver. V_{IO} should match the device's V_{CCIO}. Refer to the *MasterBlaster Serial/USB Communications Cable Data Sheet* for this value. In the ByteBlasterMV cable, this pin is a no connect. In the USB-Blaster and ByteBlaster II cable, this pin is connected to nCE when it is used for AS programming, otherwise it is a no connect.
- (4) nCE must be connected to ground or driven low for successful JTAG configuration.
- (5) If using an EPCS4 or EPCS1 device, set MSEL[1..0] to 00. See [Table 13–4](#) for more details.

Connect the nCE pin to GND or pull it low during JTAG configuration. In multiple device AS and PS configuration chains, connect the first device's nCE pin to GND and connect its nCEO pin to the nCE pin of the next device in the chain or you can use it as a user I/O pin after configuration.

After the first device completes configuration in a multiple device configuration chain, its nCEO pin drives low to activate the second device's nCE pin, which prompts the second device to begin configuration. Therefore, if these devices are also in a JTAG chain, you should make sure the nCE pins are connected to GND during JTAG configuration or that the devices are JTAG configured in the same order as the configuration chain. As long as the devices are JTAG configured in the same order as the multiple device configuration chain, the nCEO pin of the previous device will drive the nCE pin of the next device low when it has successfully been JTAG configured.



The Quartus II software sets the Cyclone II device nCEO pin as an output pin driving to ground by default. If the nCEO pin inputs to the next device's nCE pin, make sure that the nCEO pin is not used as a user I/O pin after configuration.

Other Altera devices that have JTAG support can be placed in the same JTAG chain for device programming and configuration.



For more information on configuring multiple Altera devices in the same configuration chain, see the *Configuring Mixed Altera FPGA Chains* chapter in the *Configuration Handbook*.

Jam STAPL

Jam STAPL, JEDEC standard JESD-71, is a standard file format for in-system programmability (ISP). Jam STAPL supports programming or configuration of programmable devices and testing of electronic systems using the IEEE 1149.1 JTAG interface. Jam STAPL is a freely licensed open standard. The Jam player provides an interface for manipulating the IEEE Std. 1149.1 JTAG TAP state machine.



For more information on JTAG and Jam STAPL in embedded environments, see *AN 122: Using Jam STAPL for ISP & ICR via an Embedded Processor*. To download the Jam player, go to the Altera web site (www.altera.com).

Configuring Cyclone II FPGAs with JRunner

JRunner is a software driver that allows you to configure Cyclone II devices through the ByteBlaster II or ByteBlasterMV cables in JTAG mode. The programming input file supported is in **.rbf** format. JRunner also requires a Chain Description File (**.cdf**) generated by the Quartus II software. JRunner is targeted for embedded JTAG configuration. The source code has been developed for the Windows NT operating system (OS). You can customize the code to make it run on your embedded platform.



The RBF file used by the JRunner software driver can not be a compressed RBF file because JRunner uses JTAG-based configuration. During JTAG-based configuration, the real-time decompression feature is not available.



For more information on the JRunner software driver, see *JRunner Software Driver: An Embedded Solution for PLD JTAG Configuration* and the source files on the Altera web site.

Programming Serial Configuration Devices In-System Using the JTAG Interface

Cyclone II devices in a single device chain or in a multiple device chain support in-system programming of a serial configuration device using the JTAG interface via the serial flash loader design. The board's intelligent host or download cable can use the four JTAG pins on the Cyclone II device to program the serial configuration device in system, even if the host or download cable cannot access the configuration device's configuration pins (DCLK, DATA, ASDI, and nCS pins).

The serial flash loader design is a JTAG-based in-system programming solution for Altera serial configuration devices. The serial flash loader is a bridge design for the FPGA that uses its JTAG interface to access the EPCS JIC (JTAG Indirect Configuration Device Programming) file and then uses the AS interface to program the EPCS device. Both the JTAG interface and AS interface are bridged together inside the serial flash loader design.

In a multiple device chain, you only need to configure the master Cyclone II device which is controlling the serial configuration device. The slave devices in the multiple device chain which are configured by the serial configuration device do not need to be configured when using this feature. To use this feature successfully, set the MSEL [1 . . 0] pins of the master Cyclone II device to select the AS configuration scheme or fast AS configuration scheme (see [Table 13-1](#)).



The Quartus II software version 4.1 and higher supports serial configuration device ISP through an FPGA JTAG interface using a JIC file.

The serial configuration device in-system programming through the Cyclone II JTAG interface has three stages, which are described in the following sections.

Loading the Serial Flash Loader Design

The serial flash loader design is a design inside the Cyclone II device that bridges the JTAG interface and AS interface inside the Cyclone II device using glue logic.

The intelligent host uses the JTAG interface to configure the master Cyclone II device with a serial flash loader design. The serial flash loader design allows the master Cyclone II device to control the access of four serial configuration device pins, also known as the Active Serial Memory

Interface (ASMI) pins, through the JTAG interface. The ASMI pins are the serial clock input (DCLK), serial data output (DATA), AS data input (ASDI), and an active-low chip select (nCS) pins.

If you configure a master Cyclone II device with a serial flash loader design, the master Cyclone II device can enter user mode even though the slave devices in the multiple device chain are not being configured. The master Cyclone II device can enter user mode with a serial flash loader design even though the CONF_DONE signal is externally held low by the other slave devices in chain. [Figure 13–25](#) shows the JTAG configuration of a single Cyclone II device with a serial flash loader design.

Figure 13–25. JTAG Configuration of a Single Device Using a Download Cable

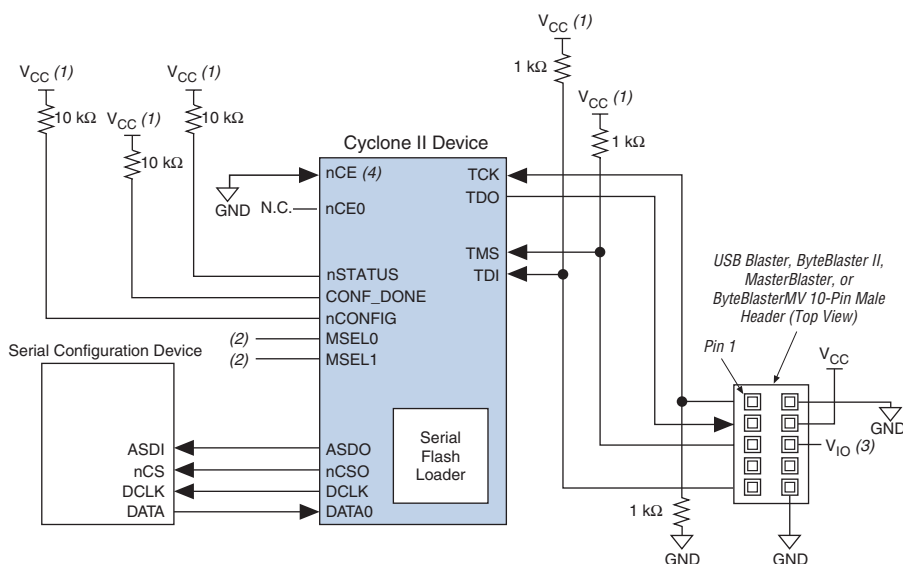

Notes to [Figure 13–25](#):

- (1) The pull-up resistor should be connected to the same supply voltage as the USB Blaster, MasterBlaster (V_{IO} pin), ByteBlaster II, or ByteBlasterMV cable.
- (2) The nCONFIG, MSEL [1 . . 0] pins should be connected to support a non-JTAG configuration scheme. If only JTAG configuration is used, connect nCONFIG to V_{CC} and MSEL [3 . . 0] to ground. Pull DCLK either high or low, whichever is convenient on your board.
- (3) Pin 6 of the header is a V_{IO} reference voltage for the MasterBlaster output driver. V_{IO} should match the device's V_{CCIO} . Refer to the *MasterBlaster Serial/USB Communications Cable Data Sheet* for this value. In the ByteBlasterMV cable, this pin is a no connect. In the USB Blaster and ByteBlaster II cables, this pin is connected to nCE when it is used for active serial programming, otherwise it is a no connect.
- (4) nCE must be connected to GND or driven low for successful JTAG configuration.

ISP of Serial Configuration Device

In the second stage, the serial flash loader design in the master Cyclone II device allows you to write the configuration data for the device chain into the serial configuration device by using the Cyclone II JTAG interface. The JTAG interface sends the programming data for the serial configuration device to the Cyclone II device first. The Cyclone II device then uses the ASMI pins to transmit the data to the serial configuration device.

Reconfiguration

After all the configuration data is written into the serial configuration device successfully, the intelligent host issues the `PULSE_NCONFIG` JTAG instruction to initialize the reconfiguration process. During reconfiguration, the master Cyclone II device will be reset and the serial flash loader design will no longer exist in the Cyclone II device and the serial configuration device will configure all the devices in the chain with your user design.

Device Configuration Pins

This section describes the connections and functionality of all the configuration related pins on the Cyclone II device. [Table 13–11](#) describes the dedicated configuration pins, which are required to be connected properly on your board for successful configuration. Some of these pins may not be required for your configuration schemes.

Table 13–11. Dedicated Configuration Pins on the Cyclone II Device (Part 1 of 5)

Pin Name	User Mode	Configuration Scheme	Pin Type	Description
MSEL [1..0]	N/A	All	Input	This pin is a two-bit configuration input that sets the Cyclone II device configuration scheme. See Table 13–1 for the appropriate settings. You must connect these pins to V_{CCIO} or ground.
nCONFIG	N/A	All	Input	This pin is a configuration control input. If this pin is pulled low during user mode, the FPGA will lose its configuration data, enter a reset state, and tri-state all I/O pins. Transitioning this pin high initiates a reconfiguration. If your configuration scheme uses an enhanced configuration device or EPC2 device, you can connect the nCONFIG pin directly to V_{CC} or to the configuration device's nINIT_CONF pin.

Table 13–11. Dedicated Configuration Pins on the Cyclone II Device (Part 2 of 5)

Pin Name	User Mode	Configuration Scheme	Pin Type	Description
nSTATUS	N/A	All	Bidirectional open-drain	<p>The Cyclone II device drives nSTATUS low immediately after power-up and releases it after the POR time.</p> <p>This pin provides a status output and input for the Cyclone II device. If the Cyclone II device detects an error during configuration, it drives the nSTATUS pin low to stop configuration. If an external source (for example, another Cyclone II device) drives the nSTATUS pin low during configuration or initialization, the target device enters an error state.</p> <p>Driving nSTATUS low after configuration and initialization does not affect the configured device. If your design uses a configuration device, driving nSTATUS low causes the configuration device to attempt to configure the FPGA, but since the FPGA ignores transitions on nSTATUS in user mode, the FPGA will not reconfigure. To initiate a reconfiguration, pull the nCONFIG pin low.</p> <p>The enhanced configuration devices' and EPC2 devices' OE and nCS pins are connected to the Cyclone II device's nSTATUS and CONF_DONE pins, respectively, and have optional internal programmable pull-up resistors. If you use these internal pull-up resistors on the enhanced configuration device, do not use external 10-kΩ pull-up resistors on these pins. When using EPC2 devices, you should only use external 10-kΩ pull-up resistors.</p>

Table 13–11. Dedicated Configuration Pins on the Cyclone II Device (Part 3 of 5)

Pin Name	User Mode	Configuration Scheme	Pin Type	Description
CONF_DONE	N/A	All	Bidirectional open-drain	<p>This pin is a status output and input.</p> <p>The target Cyclone II device drives the CONF_DONE pin low before and during configuration. Once the Cyclone II device receives all the configuration data without error and the initialization cycle starts, it releases CONF_DONE. Driving CONF_DONE low during user mode does not affect the configured device. Do not drive CONF_DONE low before the device enters user mode.</p> <p>After the Cyclone II device receives all the data, the CONF_DONE pin transitions high, and the device initializes and enters user mode.</p> <p>Driving CONF_DONE low after configuration and initialization does not affect the configured device.</p> <p>The enhanced configuration devices' and EPC2 devices' OE and nCS pins are connected to the Cyclone II device's nSTATUS and CONF_DONE pins, respectively, and have optional internal programmable pull-up resistors. If internal pull-up resistors on the enhanced configuration device are used, external 10-kΩ pull-up resistors should not be used on these pins. When using EPC2 devices, you should only use external 10-kΩ pull-up resistors.</p>
nCE	N/A	All	Input	<p>This pin is an active-low chip enable. The nCE pin activates the device with a low signal to allow configuration. The nCE pin must be held low during configuration, initialization, and user mode. In single device configuration, it should be tied low. In multiple device configuration, nCE of the first device is tied low while its nCEO pin is connected to nCE of the next device in the chain.</p> <p>The nCE pin must also be held low for successful JTAG programming of the FPGA.</p>

Table 13–11. Dedicated Configuration Pins on the Cyclone II Device (Part 4 of 5)

Pin Name	User Mode	Configuration Scheme	Pin Type	Description
nCEO	N/A if option is on. I/O if option is off.	All	Output	<p>This pin is an output that drives low when device configuration is complete. In single device configuration, you can leave this pin floating or use it as a user I/O pin after configuration. In multiple device configuration, this pin inputs the next device's nCE pin. The nCEO of the last device in the chain can be left floating or used as a user I/O pin after configuration.</p> <p>If you use the nCEO pin to feed next device's nCE pin, use an external 10-kΩ pull-up resistor to pull the nCEO pin high to the V_{CCIO} voltage of its I/O bank to help the internal weak pull-up resistor.</p> <p>Use the Quartus II software to make this pin a user I/O pin.</p>
ASDO	N/A in AS mode I/O in PS and JTAG mode	AS	Output	<p>This pin sends a control signal from the Cyclone II device to the serial configuration device in AS mode and is used to read out configuration data.</p> <p>In AS mode, ASDO has an internal pull-up that is always active.</p>
nCSO	N/A in AS mode I/O in PS and JTAG mode	AS	Output	<p>This pin sends an output control signal from the Cyclone II device to the serial configuration device in AS mode that enables the configuration device.</p> <p>In AS mode, nCSO has an internal pull-up resistor that is always active.</p>

Table 13–11. Dedicated Configuration Pins on the Cyclone II Device (Part 5 of 5)

Pin Name	User Mode	Configuration Scheme	Pin Type	Description
DCLK	N/A	PS, AS	Input (PS) Output (AS)	<p>In PS configuration, DCLK is the clock input used to clock data from an external source into the target device. Data is latched into the Cyclone II device on the rising edge of DCLK.</p> <p>In AS mode, DCLK is an output from the Cyclone II device that provides timing for the configuration interface. In AS mode, DCLK has an internal pull-up that is always active.</p> <p>After configuration, this pin is tri-stated. If you are using a configuration device, it drives DCLK low after configuration is complete. If your design uses a control host, drive DCLK either high or low. Toggling this pin after configuration does not affect the configured device.</p>
DATA0	N/A	All	Input	<p>This is the data input pin. In serial configuration modes, bit-wide configuration data is presented to the target device on the DATA0 pin.</p> <p>In AS mode, DATA0 has an internal pull-up resistor that is always active.</p> <p>After configuration, EPC1 and EPC1441 devices tri-state this pin, while enhanced configuration and EPC2 devices drive this pin high.</p>

Table 13–12 describes the optional configuration pins. If these optional configuration pins are not enabled in the Quartus II software, they are available as general-purpose user I/O pins. Therefore during configuration, these pins function as user I/O pins and are tri-stated with weak pull-up resistors.

Pin Name	User Mode	Pin Type	Description
CLKUSR	N/A if option is on. I/O if option is off.	Input	This is an optional user-supplied clock input that synchronizes the initialization of one or more devices. This pin is enabled by turning on the Enable user-supplied start-up clock (CLKUSR) option in the Quartus II software.
INIT_DONE	N/A if option is on. I/O if option is off.	Output open-drain	This is a status pin that can be used to indicate when the device has initialized and is in user mode. When $\overline{n}CONFIG$ is low and during the beginning of configuration, the INIT_DONE pin is tri-stated and pulled high due to an external 10-k Ω pull-up resistor. Once the option bit to enable INIT_DONE is programmed into the device (during the first frame of configuration data), the INIT_DONE pin will go low. When initialization is complete, the INIT_DONE pin will be released and pulled high and the FPGA enters user mode. Thus, the monitoring circuitry must be able to detect a low-to-high transition. This pin is enabled by turning on the Enable INIT_DONE output option in the Quartus II software.
DEV_OE	N/A if option is on. I/O if option is off.	Input	Optional pin that allows the user to override all tri-states on the device. When this pin is driven low, all I/O pins are tri-stated. When this pin is driven high, all I/O pins behave as programmed. This pin is enabled by turning on the Enable device-wide output enable (DEV_OE) option in the Quartus II software.
DEV_CLRn	N/A if option is on. I/O if option is off.	Input	Optional pin that allows you to override all clears on all device registers. When this pin is driven low, all registers are cleared. When this pin is driven high, all registers behave as programmed. This pin is enabled by turning on the Enable device-wide reset (DEV_CLRn) option in the Quartus II software.

Table 13–13 describes the dedicated JTAG pins. JTAG pins must be kept stable before and during configuration to prevent accidental loading of JTAG instructions. The TCK pin has a weak internal pull-down resistor and the TDI and TMS JTAG input pins have weak internal pull-up resistors.

Pin Name	User Mode	Pin Type	Description
TDI	N/A	Input	Serial input pin for instructions as well as test and programming data. Data is shifted in on the rising edge of TCK. If the JTAG interface is not required on the board, the JTAG circuitry can be disabled by connecting this pin to V_{CC} .
TDO	N/A	Output	Serial data output pin for instructions as well as test and programming data. Data is shifted out on the falling edge of TCK. The pin is tri-stated if data is not being shifted out of the device. If the JTAG interface is not required on the board, the JTAG circuitry can be disabled by leaving this pin unconnected.
TMS	N/A	Input	Input pin that provides the control signal to determine the transitions of the TAP controller state machine. Transitions within the state machine occur on the rising edge of TCK. Therefore, TMS must be set up before the rising edge of TCK. TMS is evaluated on the rising edge of TCK. If the JTAG interface is not required on the board, the JTAG circuitry can be disabled by connecting this pin to V_{CC} .
TCK	N/A	Input	The clock input to the BST circuitry. Some operations occur at the rising edge, while others occur at the falling edge. If the JTAG interface is not required on the board, the JTAG circuitry can be disabled by connecting this pin to GND.

Conclusion

Cyclone II devices can be configured in AS, PS or JTAG configuration schemes to fit your system's need. The AS configuration scheme supported by Cyclone II devices can now operate at a higher DCLK frequency (up to 40 MHz), which reduces your configuration time. In addition, Cyclone II devices can receive a compressed configuration bitstream and decompress this data on-the-fly in the AS or PS configuration scheme, which further reduces storage requirements and configuration time.

Introduction

As printed circuit boards (PCBs) become more complex, the need for thorough testing becomes increasingly important. Advances in surface-mount packaging and PCB manufacturing have resulted in smaller boards, making traditional test methods (e.g., external test probes and “bed-of-nails” test fixtures) harder to implement. As a result, cost savings from PCB space reductions are sometimes offset by cost increases in traditional testing methods.

In the 1980s, the Joint Test Action Group (JTAG) developed a specification for boundary-scan testing that was later standardized as the IEEE Std. 1149.1 specification. This boundary-scan test (BST) architecture offers the capability to efficiently test components on PCBs with tight lead spacing.

This BST architecture tests pin connections without using physical test probes and captures functional data while a device is operating normally. Boundary-scan cells in a device force signals onto pins or capture data from pin or logic array signals. Forced test data is serially shifted into the boundary-scan cells. Captured data is serially shifted out and externally compared with expected results. [Figure 14–1](#) shows the concept of boundary-scan testing.

Figure 14–1. IEEE Std. 1149.1 Boundary-Scan Testing

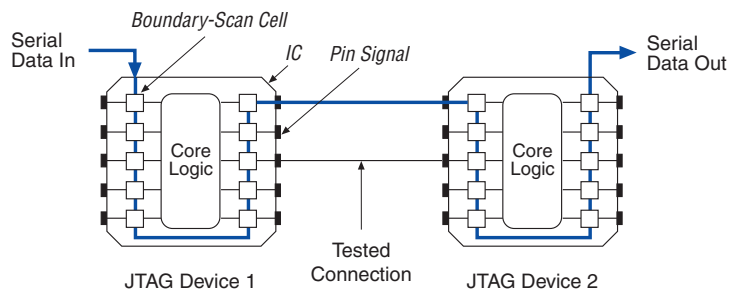

This chapter discusses how to use the IEEE Std. 1149.1 BST circuitry in Cyclone™ II devices, including:

- IEEE Std. 1149.1 BST architecture
- IEEE Std. 1149.1 boundary-scan register
- IEEE Std. 1149.1 BST operation control
- I/O voltage support in JTAG chain
- Using IEEE Std. 1149.1 BST circuitry
- Disabling IEEE Std. 1149.1 BST circuitry
- Guidelines for IEEE Std. 1149.1 boundary-scan testing
- Boundary-Scan Description Language (BSDL) support

In addition to BST, you can use the IEEE Std. 1149.1 controller for Cyclone II device in-circuit reconfiguration (ICR). However, this chapter only discusses the BST feature of the IEEE Std. 1149.1 circuitry.



For information on configuring Cyclone II devices via the IEEE Std. 1149.1 circuitry, see the *Configuring Cyclone II Devices* chapter in Volume 1 of the *Cyclone II Device Handbook*.

IEEE Std. 1149.1 BST Architecture

A Cyclone II device operating in IEEE Std. 1149.1 BST mode uses four required pins, TDI, TDO, TMS and TCK. The optional TRST pin is not available in Cyclone II devices. TDI and TMS pins have weak internal pull-up resistors while TCK has weak internal pull-down resistors. All user I/O pins are tri-stated during JTAG configuration. [Table 14–1](#) summarizes the functions of each of these pins.

Table 14–1. IEEE Std. 1149.1 Pin Descriptions

Pin	Description	Function
TDI	Test data input	Serial input pin for instructions as well as test and programming data. Signal applied to TDI is expected to change state at the falling edge of TCK. Data is shifted in on the rising edge of TCK.
TDO	Test data output	Serial data output pin for instructions as well as test and programming data. Data is shifted out on the falling edge of TCK. The pin is tri-stated if data is not being shifted out of the device.
TMS	Test mode select	Input pin that provides the control signal to determine the transitions of the TAP controller state machine. Transitions within the state machine occur at the rising edge of TCK. Therefore, TMS must be set up before the rising edge of TCK. TMS is evaluated on the rising edge of TCK. During non-JTAG operation, TMS is recommended to be driven high.
TCK	Test clock input	The clock input to the BST circuitry. Some operations occur at the rising edge, while others occur at the falling edge. The clock input waveform should have a 50% duty cycle.

The IEEE Std. 1149.1 BST circuitry requires the following registers:

- The instruction register determines the action to be performed and the data register to be accessed.
- The bypass register is a 1-bit-long data register that provides a minimum-length serial path between TDI and TDO.
- The boundary-scan register is a shift register composed of all the boundary-scan cells of the device.

Figure 14–2 shows a functional model of the IEEE Std. 1149.1 circuitry.

Figure 14–2. IEEE Std. 1149.1 Circuitry

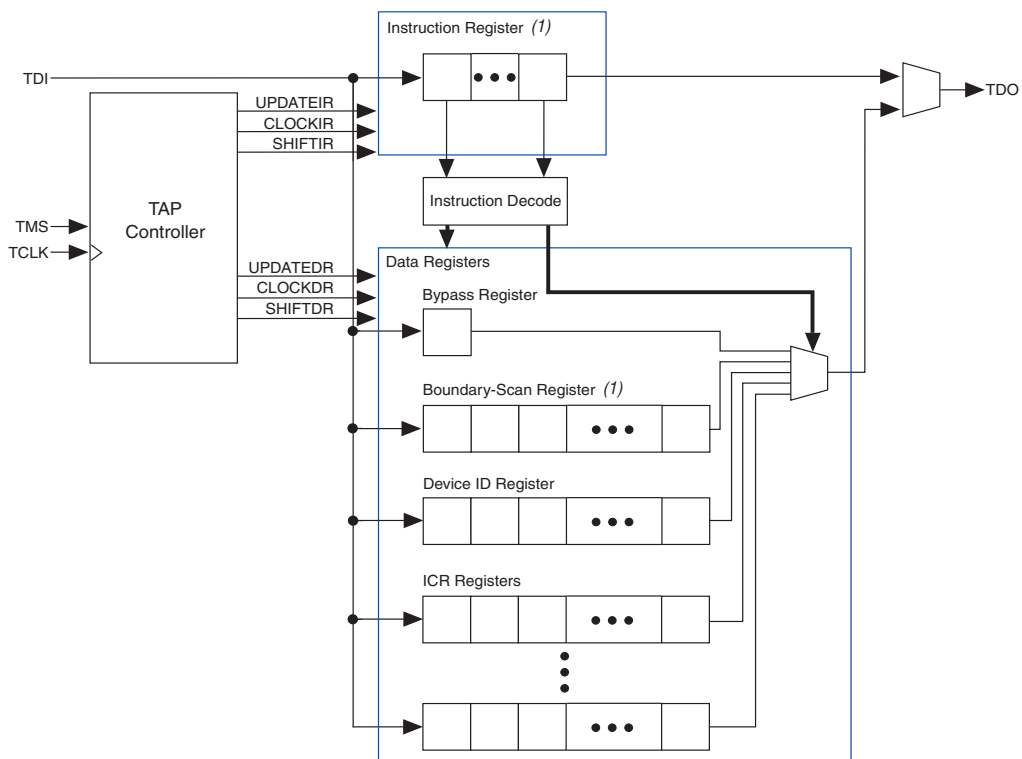

Note to Figure 14–2:

- (1) For register lengths, see the device data sheet in the *Configuration & Testing* chapter in Volume 1 of the *Cyclone II Device Handbook*.

IEEE Std. 1149.1 boundary-scan testing is controlled by a test access port (TAP) controller. For more information on the TAP controller, see “IEEE Std. 1149.1 BST Operation Control” on page 14–6. The TMS and TCK pins

operate the TAP controller, and the TDI and TDO pins provide the serial path for the data registers. The TDI pin also provides data to the instruction register, which then generates control logic for the data registers.

IEEE Std. 1149.1 Boundary-Scan Register

The boundary-scan register is a large serial shift register that uses the TDI pin as an input and the TDO pin as an output. The boundary-scan register consists of 3-bit peripheral elements that are associated with Cyclone II I/O pins. You can use the boundary-scan register to test external pin connections or to capture internal data.



See the *Configuration & Testing* chapter in Volume 1 of the *Cyclone II Device Handbook* for the Cyclone II device boundary-scan register lengths.

Figure 14–3 shows how test data is serially shifted around the periphery of the IEEE Std. 1149.1 device.

Figure 14–3. Boundary-Scan Register

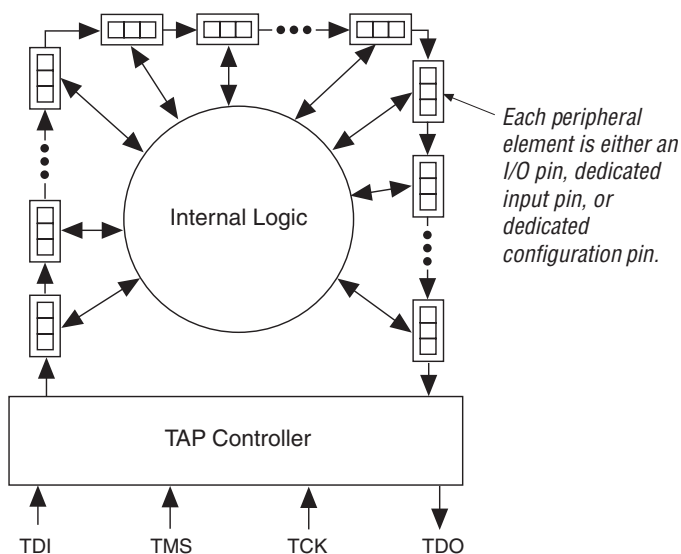

Boundary-Scan Cells of a Cyclone II Device I/O Pin

The Cyclone II device 3-bit boundary-scan cell (BSC) consists of a set of capture registers and a set of update registers. The capture registers can connect to internal device data via the $OUTJ$ and OEJ signals, and connect

to external device data via the `PIN_IN` signal, while the update registers connect to external data through the `PIN_OUT` and `PIN_OE` signals. The global control signals for the IEEE Std. 1149.1 BST registers (for example, shift, clock, and update) are generated internally by the TAP controller. The `MODE` signal is generated by a decode of the instruction register. The data signal path for the boundary-scan register runs from the serial data in (`SDI`) signal to the serial data out (`SDO`) signal. The scan register begins at the `TDI` pin and ends at the `TDO` pin of the device.

Figure 14–4 shows the Cyclone II device’s user I/O boundary-scan cell.

Figure 14–4. Cyclone II Device's User I/O BSC with IEEE Std. 1149.1 BST Circuitry

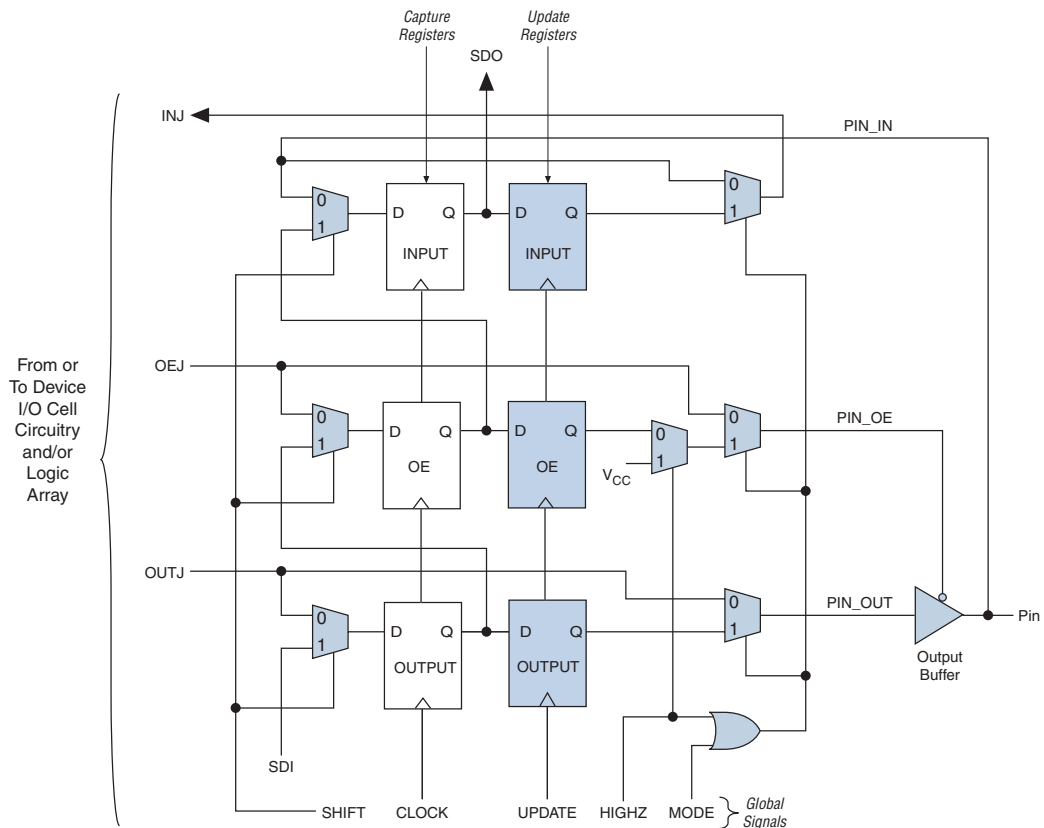

Table 14–2 describes the capture and update register capabilities of all types of boundary-scan cells within Cyclone II devices.

Table 14–2. Cyclone II Device Boundary Scan Cell Descriptions *Note (1)*

Pin Type	Captures			Drives			Comments
	Output Capture Register	OE Capture Register	Input Capture Register	Output Update Register	OE Update Register	Input Update Register	
User I/O pins	OUTJ	OEJ	PIN_IN	PIN_OUT	PIN_OE	INJ	
Dedicated clock input	0	1	PIN_IN	N.C. (2)	N.C. (2)	N.C. (2)	PIN_IN drives to clock network or logic array
Dedicated input (3)	0	1	PIN_IN	N.C. (2)	N.C. (2)	N.C. (2)	PIN_IN drives to control logic
Dedicated bidirectional (4)	0	OEJ	PIN_IN	N.C. (2)	N.C. (2)	N.C. (2)	PIN_IN drives to configuration control
Dedicated output (5)	OUTJ	0	0	N.C. (2)	N.C. (2)	N.C. (2)	OUTJ drives to output buffer

Notes to Table 14–2:

- (1) TDI, TDO, TMS, TCK, all V_{CC} and GND pin types do not have BSCs.
- (2) N.C.: no connect.
- (3) This includes nCONFIG, MSEL0, MSEL1, and nCE pins.
- (4) This includes CONF_DONE and nSTATUS pins.
- (5) This includes nCEO pins.

IEEE Std. 1149.1 BST Operation Control

Cyclone II devices implement the following IEEE Std. 1149.1 BST instructions: SAMPLE/PRELOAD, EXTEST, BYPASS, IDCODE, USERCODE, CLAMP, and HIGHZ. The BST instruction length is 10 bits. These instructions are described later in this chapter.



For summaries of the BST instructions and their instruction codes, see the *Configuration & Testing* chapter in Volume 1 of the *Cyclone II Device Handbook*.

The IEEE Std. 1149.1 test access port (TAP) controller, a 16-state state machine clocked on the rising edge of TCK, uses the TMS pin to control IEEE Std. 1149.1 operation in the device. Figure 14–5 shows the TAP controller state machine.

Figure 14-5. IEEE Std. 1149.1 TAP Controller State Machine

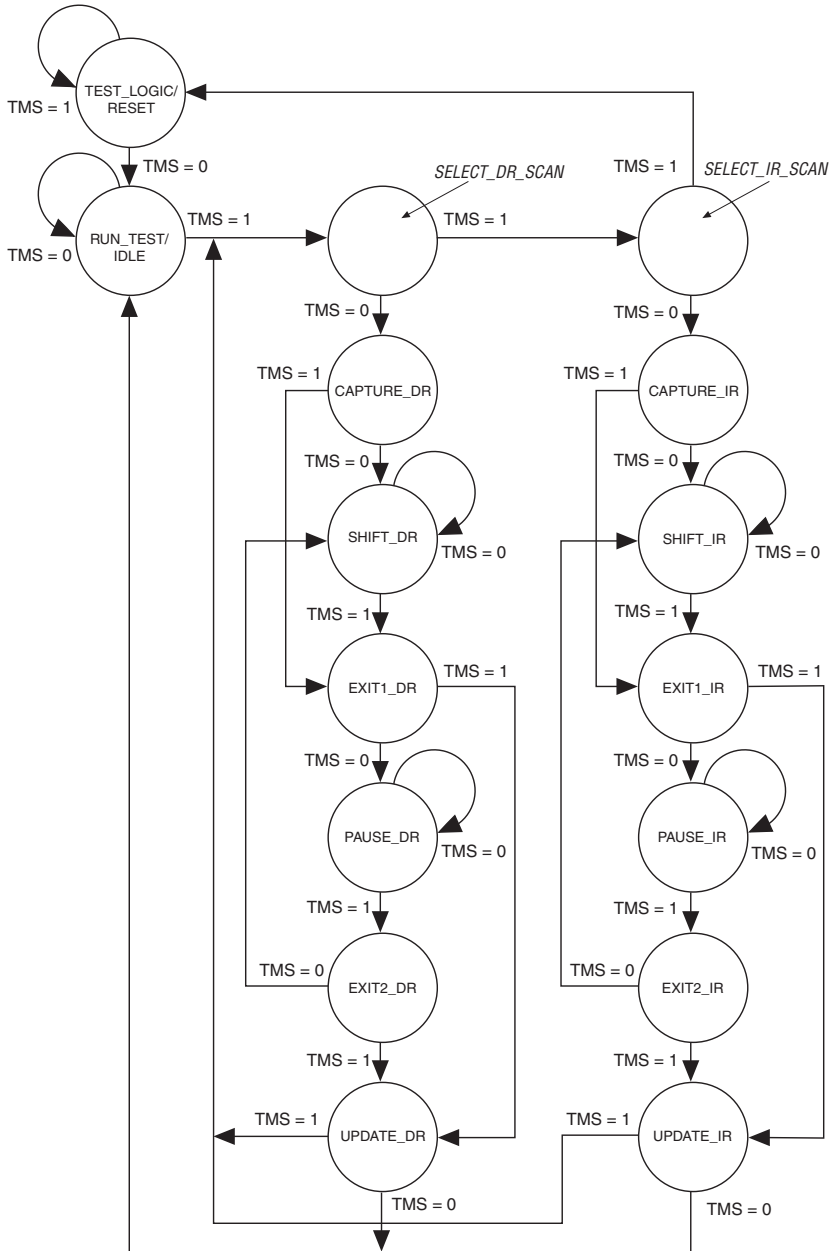

When the TAP controller is in the TEST_LOGIC/RESET state, the BST circuitry is disabled, the device is in normal operation, and the instruction register is initialized with IDCODE as the initial instruction. At device power-up, the TAP controller starts in this TEST_LOGIC/RESET state. In addition, forcing the TAP controller to the TEST_LOGIC/RESET state is done by holding TMS high for five TCK clock cycles. Once in the TEST_LOGIC/RESET state, the TAP controller remains in this state as long as TMS is held high (while TCK is clocked). Figure 14–6 shows the timing requirements for the IEEE Std. 1149.1 signals.

Figure 14–6. IEEE Std. 1149.1 Timing Waveforms

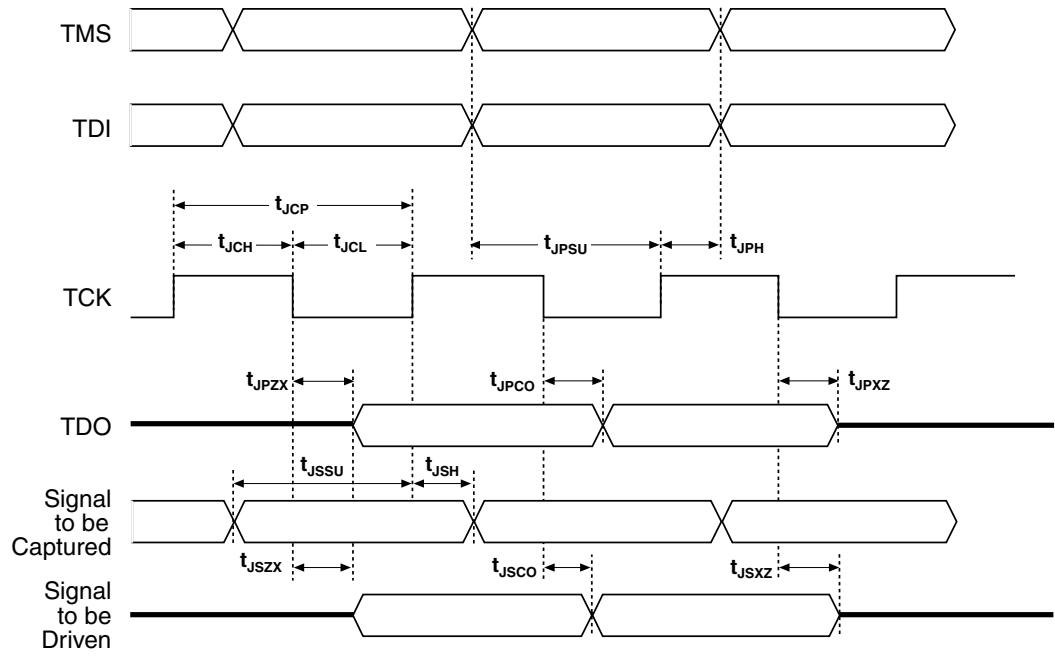

To start IEEE Std. 1149.1 operation, select an instruction mode by advancing the TAP controller to the shift instruction register (SHIFT_IR) state and shift in the appropriate instruction code on the TDI pin. The waveform diagram in Figure 14–7 represents the entry of the instruction code into the instruction register. It shows the values of TCK, TMS, TDI, TDO, and the states of the TAP controller. From the RESET state, TMS is clocked with the pattern 01100 to advance the TAP controller to SHIFT_IR.

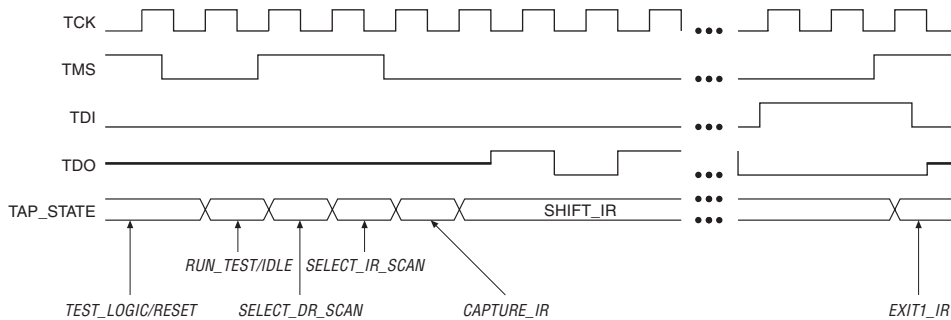
Figure 14–7. Selecting the Instruction Mode

The TDO pin is tri-stated in all states except in the `SHIFT_IR` and `SHIFT_DR` states. The TDO pin is activated at the first falling edge of TCK after entering either of the shift states and is tri-stated at the first falling edge of TCK after leaving either of the shift states.

When the `SHIFT_IR` state is activated, TDO is no longer tri-stated, and the initial state of the instruction register is shifted out on the falling edge of TCK. TDO continues to shift out the contents of the instruction register as long as the `SHIFT_IR` state is active. The TAP controller remains in the `SHIFT_IR` state as long as TMS remains low.

During the `SHIFT_IR` state, an instruction code is entered by shifting data on the TDI pin on the rising edge of TCK. The last bit of the instruction code must be clocked at the same time that the next state, `EXIT1_IR`, is activated. Set TMS high to activate the `EXIT1_IR` state. Once in the `EXIT1_IR` state, TDO becomes tri-stated again. TDO is always tri-stated except in the `SHIFT_IR` and `SHIFT_DR` states. After an instruction code is entered correctly, the TAP controller advances to serially shift test data in one of seven modes (`SAMPLE/PRELOAD`, `EXTEST`, `BYPASS`, `IDCODE`, `USERCODE`, `CLAMP`, or `HIGHZ`) that are described below.

SAMPLE/PRELOAD Instruction Mode

The `SAMPLE/PRELOAD` instruction mode allows you to take a snapshot of device data without interrupting normal device operation. You can also use this instruction to preload the test data into the update registers prior to loading the `EXTEST` instruction. [Figure 14–8](#) shows the capture, shift, and update phases of the `SAMPLE/PRELOAD` mode.

Figure 14–8. IEEE Std. 1149.1 BST SAMPLE/PRELOAD Mode

Capture Phase

In the capture phase, the signals at the pin, OEJ and OUTJ, are loaded into the capture registers. The CLOCK signals are supplied by the TAP controller's CLOCKDR output. The data retained in these registers consists of signals from normal device operation.

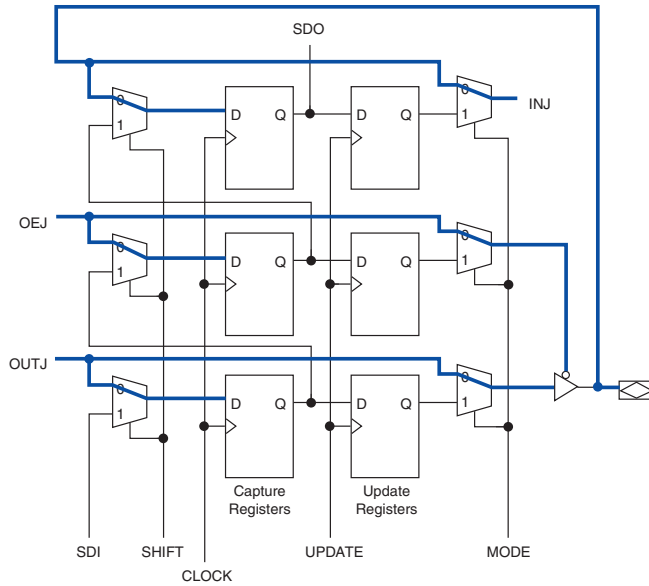

Shift & Update Phases

In the shift phase, the previously captured signals at the pin, OEJ and OUTJ, are shifted out of the boundary-scan register via the TDO pin using CLOCK. As data is shifted out, the patterns for the next test can be shifted in via the TDI pin.

In the update phase, data is transferred from the capture to the UPDATE registers using the UPDATE clock. The data stored in the UPDATE registers can be used for the EXTEST instruction.

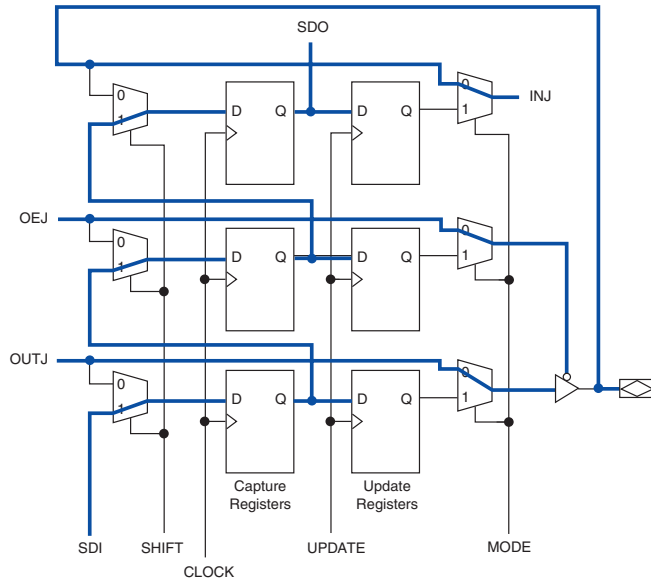

During the capture phase, multiplexers preceding the capture registers select the active device data signals. This data is then clocked into the capture registers. The multiplexers at the outputs of the update registers also select active device data to prevent functional interruptions to the device. During the shift phase, the boundary-scan shift register is formed by clocking data through capture registers around the device periphery, then out of the TDO pin. The device can simultaneously shift new test data into TDI and replace the contents of the capture registers. During the update phase, data in the capture registers is transferred to the update registers. This data can then be used in the EXTEST instruction mode. See “EXTEST Instruction Mode” on page 14–11 for more information.

Figure 14–9 shows the SAMPLE/PRELOAD waveforms. The SAMPLE/PRELOAD instruction code is shifted in through the TDI pin. The TAP controller advances to the CAPTURE_DR state, then to the SHIFT_DR state, where it remains if TMS is held low. The data that was present in the capture registers after the capture phase is shifted out of the TDO pin. New test data shifted into the TDI pin appears at the TDO pin after being clocked through the entire boundary-scan register. Figure 14–9 shows that the instruction code at TDI does not appear at the TDO pin until after the capture register data is shifted out. If TMS is held high on two consecutive TCK clock cycles, the TAP controller advances to the UPDATE_DR state for the update phase.

Figure 14–9. SAMPLE/PRELOAD Shift Data Register Waveforms

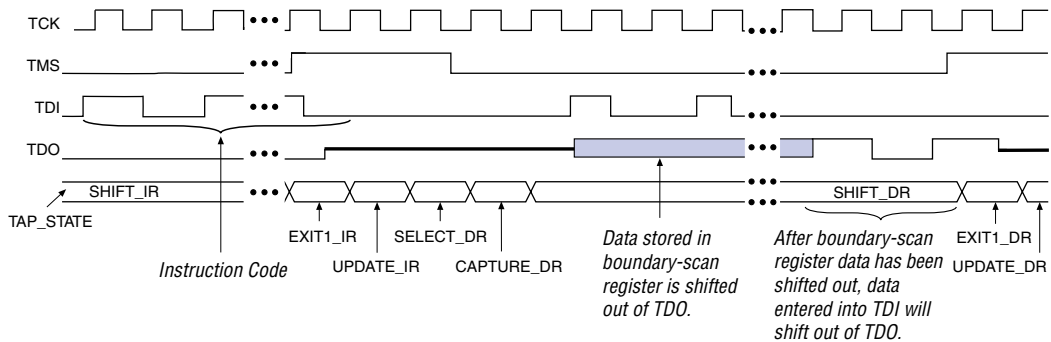

EXTEST Instruction Mode

The EXTEST instruction mode is used to check external pin connections between devices. Unlike the SAMPLE/PRELOAD mode, EXTEST allows test data to be forced onto the pin signals. By forcing known logic high and low levels on output pins, opens and shorts can be detected at pins of any device in the scan chain.

EXTEST selects data differently than SAMPLE/PRELOAD. EXTEST chooses data from the update registers as the source of the output and output enable signals. Once the EXTEST instruction code is entered, the multiplexers select the update register data. Thus, data stored in these registers from a previous EXTEST or SAMPLE/PRELOAD test cycle can be forced onto the pin signals. In the capture phase, the results of this test data are stored in the capture registers, then shifted out of TDO during the shift phase. New test data can then be stored in the update registers during the update phase.

The EXTEST waveform diagram in Figure 14–11 resembles the SAMPLE/PRELOAD waveform diagram, except for the instruction code. The data shifted out of TDO consists of the data that was present in the capture registers after the capture phase. New test data shifted into the TDI pin appears at the TDO pin after being clocked through the entire boundary-scan register.

Figure 14–11. EXTEST Shift Data Register Waveforms

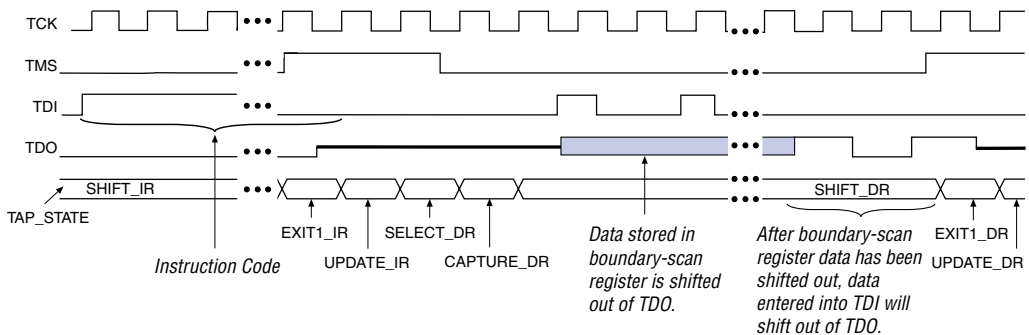

BYPASS Instruction Mode

The BYPASS mode is activated when an instruction code of all 1's is loaded in the instruction register. The waveforms in Figure 14–12 show how scan data passes through a device once the TAP controller is in the SHIFT_DR state. In this state, data signals are clocked into the bypass register from TDI on the rising edge of TCK and out of TDO on the falling edge of the same clock pulse.

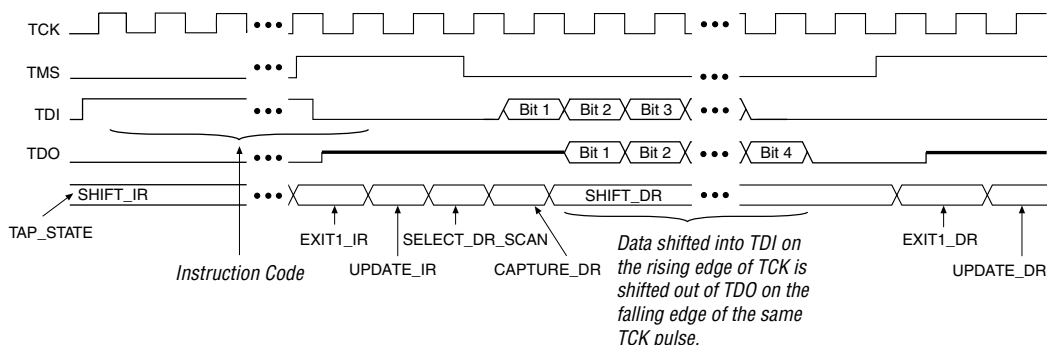
Figure 14–12. BYPASS Shift Data Register Waveforms

IDCODE Instruction Mode

The IDCODE instruction mode is used to identify the devices in an IEEE Std. 1149.1 chain. When IDCODE is selected, the device identification register is loaded with the 32-bit vendor-defined identification code. The device ID register is connected between the TDI and TDO ports, and the device IDCODE is shifted out. The IDCODE for Cyclone II devices are listed in the *Configuration & Testing* chapter in Volume 1 of the *Cyclone II Device Handbook*.

USERCODE Instruction Mode

The USERCODE instruction mode is used to examine the user electronic signature (UES) within the devices along an IEEE Std. 1149.1 chain. When this instruction is selected, the device identification register is connected between the TDI and TDO ports. The user-defined UES is shifted into the device ID register in parallel from the 32-bit USERCODE register. The UES is then shifted out through the device ID register. The UES value will not be user defined until after the device has been configured. Before configuration, the UES value will be set to the default value.

CLAMP Instruction Mode

The CLAMP instruction mode is used to allow the boundary-scan register to determine the state of the signals driven from the pins. In CLAMP instruction mode, the bypass register is selected as the serial path between the TDI and TDO ports.

If you are testing the device after configuring it, the programmable weak pull-up resistor or the bus hold feature will override the CLAMP value (the value stored in the update register of the boundary-scan cell) at the pin.

HIGHZ Instruction Mode

The HIGHZ instruction mode is used to set all of the user I/O pins to an inactive drive state. These pins are tri-stated until a new JTAG instruction is executed. When this instruction is loaded into the instruction register, the bypass register is connected between the TDI and TDO ports.

If you are testing the device after configuring it, the programmable weak pull-up resistor or the bus hold feature will override the HIGHZ value at the pin.

I/O Voltage Support in JTAG Chain

A JTAG chain can contain several different devices. However, you should be cautious if the chain contains devices that have different V_{CCIO} levels. The output voltage level of the TDO pin must meet the specifications of the TDI pin it drives. For Cyclone II devices, the TDO pin is powered by the V_{CCIO} power supply. Since the V_{CCIO} supply is 3.3 V, the TDO pin will drive out 3.3 V.

Devices can interface with each other although they might have different V_{CCIO} levels. For example, a device with a 3.3-V TDO pin can drive to a device with a 5.0-V TDI pin because 3.3 V meets the minimum TTL-level V_{IH} for the 5.0-V TDI pin. JTAG pins on Cyclone II devices can support 2.5- or 3.3-V input levels.



For more information on MultiVolt I/O support, see the *Cyclone II Architecture* chapter in Volume 1 of the *Cyclone II Device Handbook*.

You can also interface the TDI and TDO lines of the devices that have different V_{CCIO} levels by inserting a level shifter between the devices. If possible, the JTAG chain should be built such that a device with a higher V_{CCIO} level drives to a device with an equal or lower V_{CCIO} level. This way, a level shifter may be required only to shift the TDO level to a level acceptable to the JTAG tester. [Figure 14-13](#) shows the JTAG chain of mixed voltages and how a level shifter is inserted in the chain.

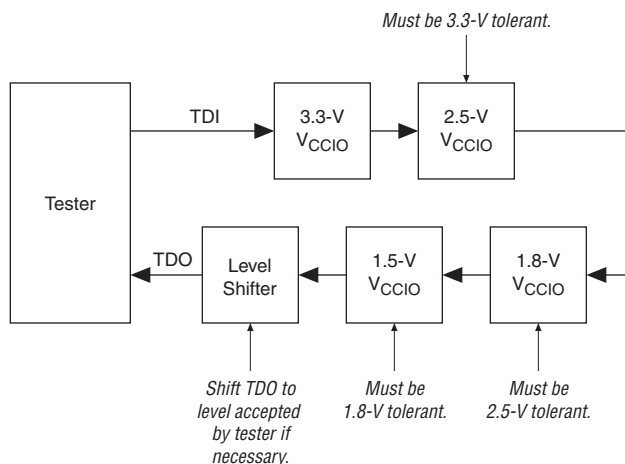
Figure 14–13. JTAG Chain of Mixed Voltages

Using IEEE Std. 1149.1 BST Circuitry

Cyclone II devices have dedicated JTAG pins, and the IEEE Std. 1149.1 BST circuitry is enabled upon device power-up. You can perform BST on Cyclone II FPGAs not only before and after configuration, but also during configuration. Cyclone II FPGAs support the `BYPASS`, `IDCODE`, and `SAMPLE` instructions during configuration without interrupting configuration. To send all other JTAG instructions, you must interrupt configuration using the `CONFIG_IO` instruction.

The `CONFIG_IO` instruction allows you to configure I/O buffers via the JTAG port, and when issued, interrupts configuration. This instruction allows you to perform board-level testing prior to configuring the Cyclone II FPGA or waiting for a configuration device to complete configuration. Once configuration has been interrupted and JTAG BST is complete, the part must be reconfigured via JTAG (`PULSE_CONFIG` instruction) or by pulsing `nCONFIG` low.

When you perform JTAG boundary-scan testing before configuration, the `nCONFIG` pin must be held low.

The device-wide reset (`DEV_CLRn`) and device-wide output enable (`DEV_OE`) pins on Cyclone II devices do not affect JTAG boundary-scan or configuration operations. Toggling these pins does not disrupt BST operation any more than usual.

When designing a board for JTAG configuration of Cyclone II devices, the connections for the dedicated configuration pins need to be considered.



For more information on using the IEEE Std.1149.1 circuitry for device configuration, see the *Configuring Cyclone II Devices* chapter in Volume 1 of the *Cyclone II Device Handbook*.

Disabling IEEE Std. 1149.1 BST Circuitry

The IEEE Std. 1149.1 BST circuitry for Cyclone II devices is enabled upon device power-up. Because this circuitry may be used for BST or in-circuit reconfiguration, this circuitry must be enabled only at specific times as mentioned in “Using IEEE Std. 1149.1 BST Circuitry” on page 14–16.

If the IEEE Std. 1149.1 circuitry will not be utilized at any time, the circuitry should be permanently disabled. Table 14–3 shows the pin connections necessary for disabling the IEEE Std. 1149.1 circuitry in Cyclone II devices to ensure that the circuitry is not inadvertently enabled when it is not needed.

Table 14–3. Disabling IEEE Std. 1149.1 Circuitry

JTAG Pins (1)	Connection for Disabling
TMS	V _{CC}
TCK	GND
TDI	V _{CC}
TDO	Leave open

Note to Table 14–3:

- (1) There is no software option to disable JTAG in Cyclone II devices. The JTAG pins are dedicated.

Guidelines for IEEE Std. 1149.1 Boundary-Scan Testing

Use the following guidelines when performing boundary-scan testing with IEEE Std. 1149.1 devices:

- If the 10-bit checkerboard pattern “1010101010” does not shift out of the instruction register via the TDO pin during the first clock cycle of the SHIFT_IR state, the TAP controller has not reached the proper state. To solve this problem, try one of the following procedures:
 - Verify that the TAP controller has reached the SHIFT_IR state correctly. To advance the TAP controller to the SHIFT_IR state, return to the RESET state and send the code 01100 to the TMS pin.
 - Check the connections to the V_{CC}, GND, JTAG, and dedicated configuration pins on the device.

- Perform a `SAMPLE/PRELOAD` test cycle prior to the first `EXTEST` test cycle to ensure that known data is present at the device pins when the `EXTEST` mode is entered. If the `OEJ` update register contains a 0, the data in the `OUTJ` update register will be driven out. The state must be known and correct to avoid contention with other devices in the system.
- Do not perform `EXTEST` testing during `ICR`. This instruction is supported before or after `ICR`, but not during `ICR`. Use the `CONFIG_IO` instruction to interrupt configuration, then perform testing, or wait for configuration to complete.
- If performing testing before configuration, hold the `nCONFIG` pin low.
- After configuration, any pins in a differential pin pair cannot be tested. Therefore, performing `BST` after configuration requires editing `BSC` group definitions that correspond to these differential pin pairs. The `BSC` group should be redefined as an internal cell. See the `BSDL` file for more information on editing.

For more information on boundary scan testing, contact Altera Applications.

Boundary-Scan Description Language (BSDL) Support

The Boundary-Scan Description Language (BSDL), a subset of VHDL, provides a syntax that allows you to describe the features of an IEEE Std. 1149.1 BST-capable device that can be tested. Test software development systems then use the `BSDL` files for test generation, analysis, and failure diagnostics. For more information, or to receive `BSDL` files for IEEE Std. 1149.1-compliant Cyclone II devices, visit the Altera web site at www.altera.com.

Conclusion

The IEEE Std. 1149.1 BST circuitry available in Cyclone II devices provides a cost-effective and efficient way to test systems that contain devices with tight lead spacing. Circuit boards with Altera and other IEEE Std. 1149.1-compliant devices can use the `EXTEST`, `SAMPLE/PRELOAD`, `BYPASS`, `IDCODE`, `USERCODE`, `CLAMP`, and `HIGHZ` modes to create serial patterns that internally test the pin connections between devices and check device operation.

References

Bleeker, H., P. van den Eijnden, and F. de Jong. *Boundary-Scan Test: A Practical Approach*. Eindhoven, The Netherlands: Kluwer Academic Publishers, 1993.

Institute of Electrical and Electronics Engineers, Inc. *IEEE Standard Test Access Port and Boundary-Scan Architecture* (IEEE Std 1149.1-2001). New York: Institute of Electrical and Electronics Engineers, Inc., 2001.

Maunder, C. M., and R. E. Tulloss. *The Test Access Port and Boundary-Scan Architecture*. Los Alamitos: IEEE Computer Society Press, 1990.

This section provides information for board layout designers to successfully layout their boards for Cyclone™ II devices. The chapters in this section contain the required PCB layout guidelines and package specifications.

This section includes the following chapters:

- [Chapter 15, Package Information for Cyclone II Devices](#)

Revision History

The table below shows the revision history for [Chapters 11](#) and [15](#).

Chapter(s)	Date / Version	Changes Made
15	November 2004, v1.0	Added document to the Cyclone II Device Handbook.

Introduction

This chapter provides package information for Altera® Cyclone™ II devices, including:

- Device and package cross reference
- Thermal resistance values
- Package outlines

Table 15–1 shows Cyclone II device package options.

<i>Table 15–1. Cyclone II Device Package Options</i>		
Device	Package	Pins
EP2C5	Plastic Thin Quad Flat Pack (TQFP)	144
	Plastic Quad Flat Pack (PQFP)	208
	Low profile FineLine BGA®	256
EP2C8	TQFP	144
	PQFP	208
	Low profile FineLine BGA	256
EP2C20	PQFP	208
	Low profile FineLine BGA	256
	Thermally enhanced FineLine BGA	484
EP2C35	Thermally enhanced FineLine BGA	484
	Thermally enhanced FineLine BGA	672
EP2C50	Thermally enhanced FineLine BGA	896
EP2C70	Thermally enhanced FineLine BGA	672
	Thermally enhanced FineLine BGA	896

Thermal Resistance

Table 15–2 provides θ_{JA} (junction-to-ambient thermal resistance) and θ_{JC} (junction-to-case thermal resistance) values for Cyclone II devices.

Table 15–2. Thermal Resistance of Cyclone II Devices

Device	Pin Count	Package	θ_{JA} (°C/W) Still Air	θ_{JA} (°C/W) 100ft./min.	θ_{JA} (°C/W) 200ft./min.	θ_{JA} (°C/W) 400ft./min.	θ_{JC} (°C/W)
EP2C5	144	TQFP	31	29.3	27.9	25.5	10
	208	PQFP	30.4	29.2	27.3	22.3	5.5
	256	FineLine BGA	30.2	26.1	23.6	21.7	8.7
EP2C8	144	TQFP	29.8	28.3	26.9	24.9	9.9
	208	PQFP	30.2	28.8	26.9	21.7	5.4
	256	FineLine BGA	27	23	20.5	18.5	7.1
EP2C20	208	PQFP	29.6	28.1	25.8	20.6	5.2
	256	FineLine BGA	24.2	20	17.8	16	5.5
	484	FineLine BGA	21	17	14.8	13.1	4.2
EP2C35	484	FineLine BGA	19.4	15.4	13.3	11.7	3.3
	672	FineLine BGA	18.6	14.6	12.6	11.1	3.1
EP2C50	484	FineLine BGA	18.4	14.4	12.4	10.9	2.8
	672	FineLine BGA	17.7	13.7	11.8	10.2	2.6
EP2C70	672	FineLine BGA	16.9	13	11.1	9.7	2.2
	896	FineLine BGA	16.3	11.9	10.5	9.1	2.1

Package Outlines

The package outlines on the following pages are listed in order of ascending pin count.

144-Pin Plastic Thin Quad Flat Pack

- All dimensions and tolerances conform to ASME Y14.5M - 1994.
- Controlling dimension is in millimeters.
- Pin 1's location may be indicated by an ID dot in its proximity on the package surface.

Tables 15–3 and 15–4 show package information for the 144-pin TQFP.

Table 15–3. Package Information

Description	Specification
Ordering code reference	T
Package acronym	TQFP
Leadframe material	Copper
Lead finish (plating)	Regular: 85Sn: 15Pb (typical) Pb-free: matte tin
JEDEC outline reference	MS-026 variation: BFB
Maximum lead coplanarity	0.003 inches (0.08mm)
Weight	1.3 g
Moisture sensitivity level	Printed on moisture barrier bag

Table 15–4. Package Outline Figure Reference

Symbol	Dimensions (mm)		
	Min.	Nom.	Max.
A	–	–	1.60
A1	0.05	–	0.15
A2	1.30	1.40	1.45
D	22.00 BSC		
D1	20.00 BSC		
E	22.00 BSC		
E1	20.00 BSC		
L	0.45	0.60	0.75
L1	1.00 REF		
S	0.20	–	–
b	0.17	0.22	0.27
e	0.50 BSC		
θ	0°	3.5°	7°

Figure 15–1 shows a package outline for the 144-pin TQFP.

Figure 15–1. Package Outline for 144-Pin TQFP

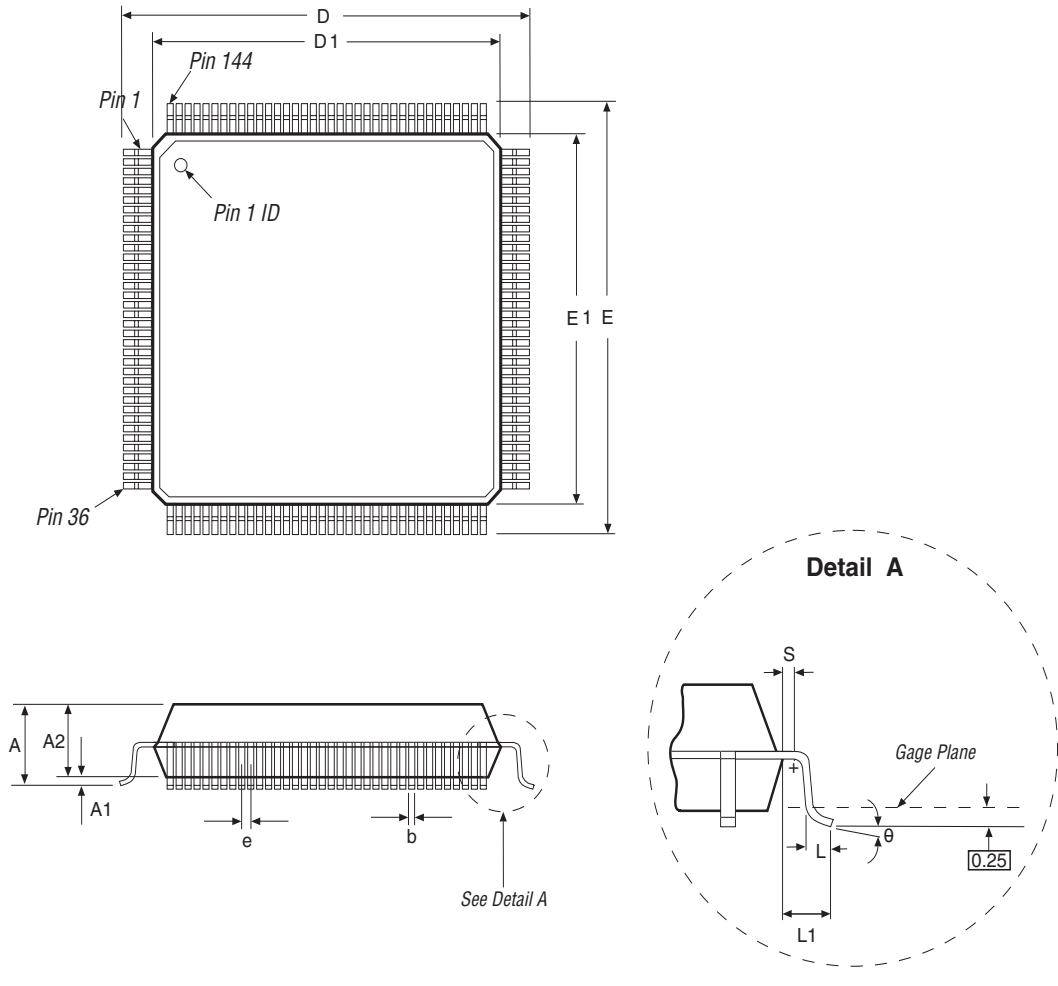

208-Pin Plastic Quad Flat Pack Package

- All dimensions and tolerances conform to ASME Y14.5M - 1994.
- Controlling dimension is in millimeters.
- Pin 1's location may be indicated by an ID dot in its proximity on the package surface.

Figures 15–5 and 15–6 show package information for the 208-pin PQFP.

Description	Specification
Ordering code reference	Q
Package acronym	PQFP
Leadframe material	Copper
Lead finish (plating)	Regular: 85Sn: 15Pb (typical) Pb-free: matte tin
JEDEC outline reference	MS-029 variation: FA-1
Maximum lead coplanarity	0.003 inches (0.08 mm)
Weight	5.7 g
Moisture sensitivity level	Printed on moisture barrier bag

Symbol	Dimensions (mm)		
	Min.	Nom.	Max.
A	–	–	4.10
A1	0.25	–	0.50
A2	3.20	3.40	3.60
D	30.60 BSC		
D1	28.00 BSC		
E	30.60 BSC		
E1	28.00 BSC		
L	0.50	0.60	0.75
L1	1.30 REF		
S	0.40	–	–
b	0.17	–	0.27
e	0.50 BSC		
θ	0°	3.5°	8°

Figure 15–2 shows a package outline for the 208-pin PQFP.

Figure 15–2. Package Outline for 208-Pin PQFP

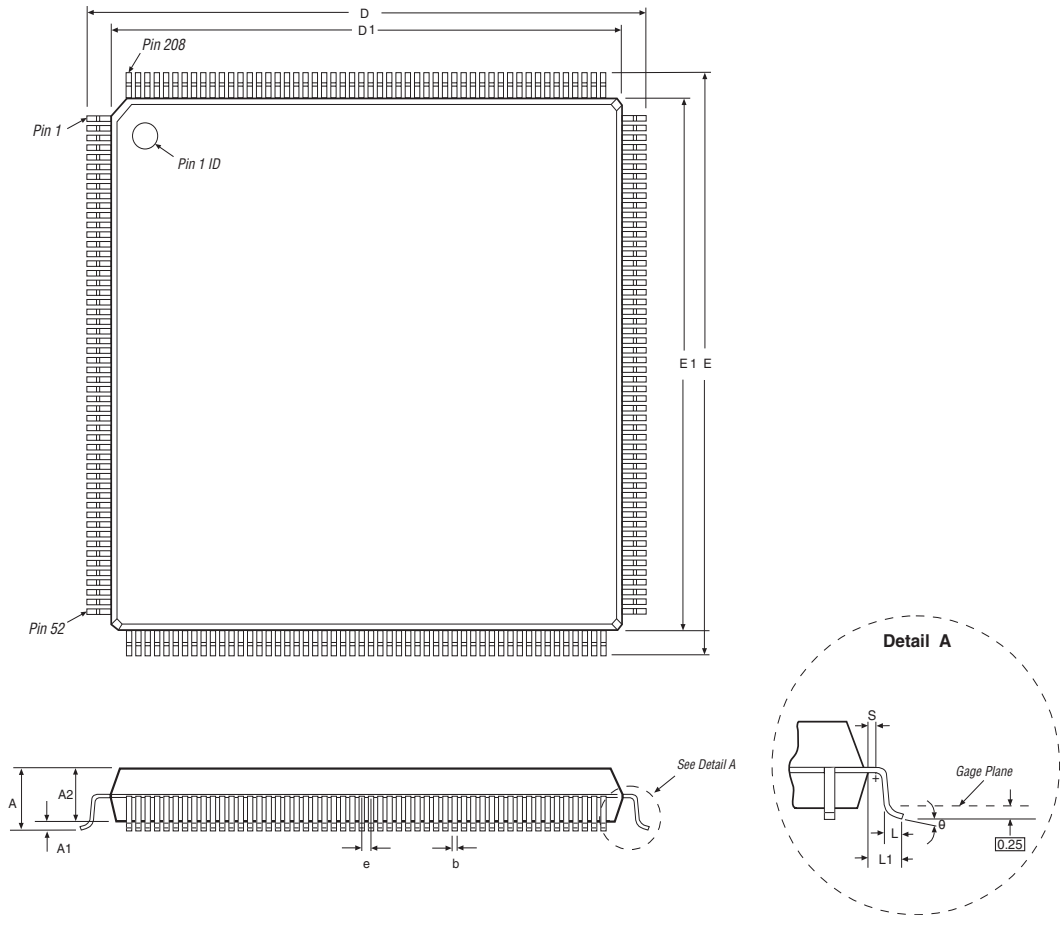

256-Pin Low Profile FineLine BGA Package

- All dimensions and tolerances conform to ASME Y14.5M - 1994.
- Controlling dimension is in millimeters.
- Pin A1's location may be indicated by an ID dot in its proximity on the package surface.

Tables 15–7 and 15–8 show package information for the 256-pin low profile package.

Description	Specification
Ordering code reference	F
Package acronym	FineLine BGA
Substrate material	BT
Solder ball composition	Regular: 63Sn: 37Pb (typical) Pb-free: Sn: 3Ag: 0.5Cu (typical)
JEDEC outline reference	MS-034 variation AAF-1
Maximum lead coplanarity	0.008 inches (0.20 mm)
Weight	1.9 g
Moisture sensitivity level	Printed on moisture barrier bag

Symbol	Dimensions (mm)		
	Min.	Nom.	Max.
A	–	–	1.55
A1	0.25	–	–
A2		1.05 REF	
A3	–	–	0.80
D	17.00 BSC		
E	17.00 BSC		
b	0.40	0.50	0.60
e	1.00 BSC		

Figure 15–3 shows the package outline for low profile package.

Figure 15–3. Package Outline for 256-Pin Low Profile Package

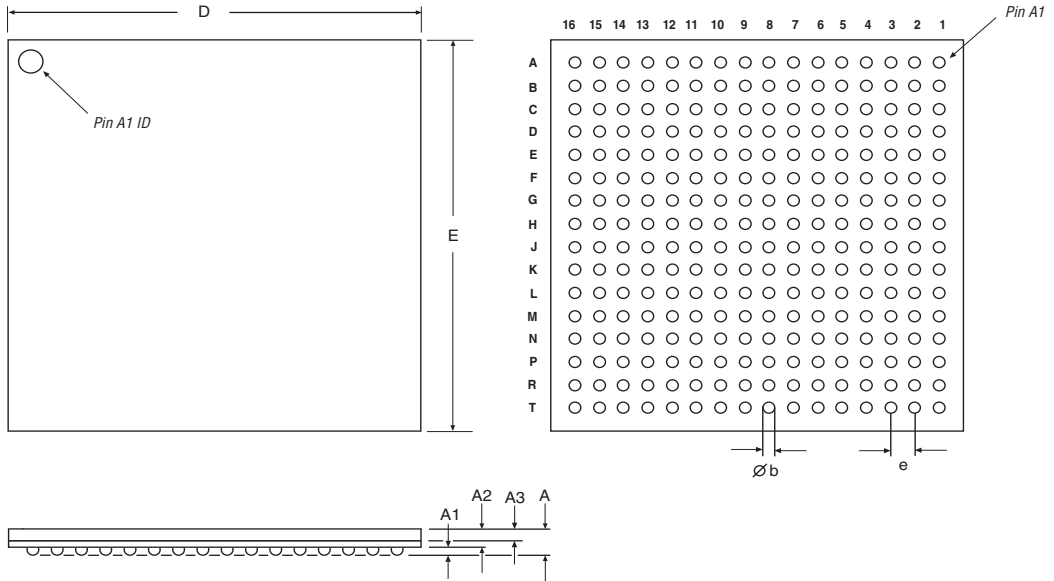

484-Pin Thermally Enhanced FineLine BGA Package

- All dimensions and tolerances conform to ASME Y14.5M - 1994.
- Controlling dimension is in millimeters.
- Some devices have a chamfered corner at the A1 ball location.
- Pin A1 location may be indicated by an ID dot in its proximity on the package surface.

Tables 15–9 and 15–10 show package information for the 484-pin thermally enhanced package.

Description	Specification
Ordering code reference	F
Package acronym	FineLine BGA
Substrate material	BT
Solder ball composition	Regular: 63Sn: 37Pb (typical) Pb-free: Sn: 3Ag: 0.5Cu (typical)
JEDEC outline reference	MS-034 variation AAJ-1
Maximum lead coplanarity	0.008 inches (0.20 mm)
Weight	5.7 g
Moisture sensitivity level	Printed on moisture barrier bag

Symbol	Dimensions (mm)		
	Min.	Nom.	Max.
A	–	–	2.60
A1	0.30	–	–
A2	–	–	2.30
A3	–	–	1.80
D	23.00 BSC		
E	23.00 BSC		
b	0.50	0.60	0.70
e	1.00 BSC		

Figure 15–4 shows a package outline for the 484-pin thermally enhanced package.

Figure 15–4. Package Outline for 484-Pin Thermally Enhanced Package

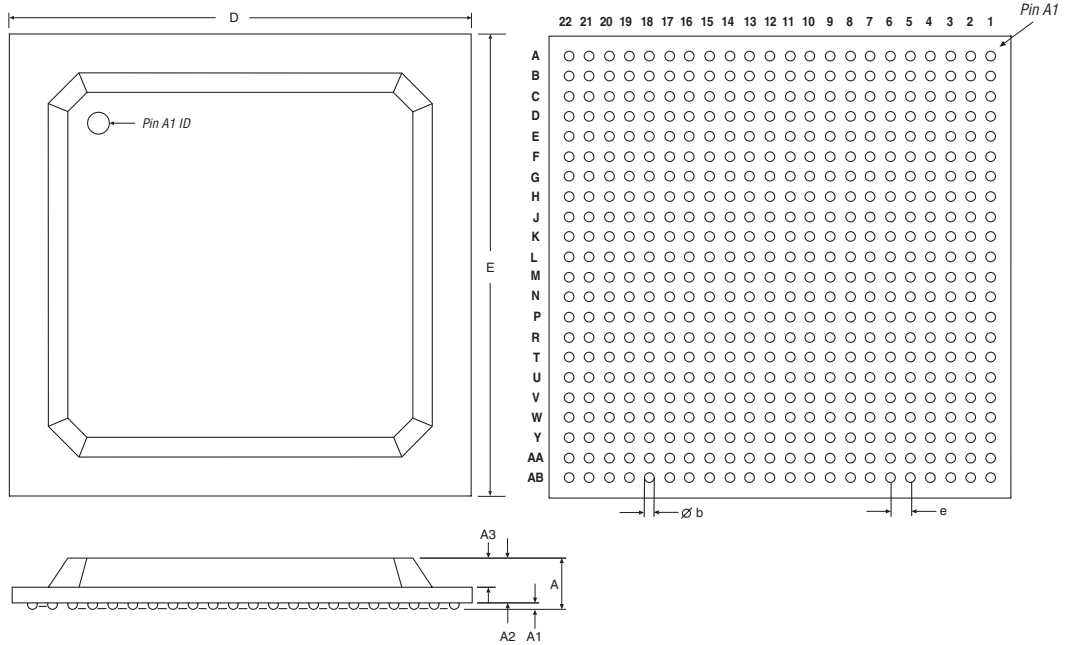

672-Pin Thermally Enhanced FineLine BGA Package

- All dimensions and tolerances conform to ASME Y14.5M - 1994.
- Controlling dimension is in millimeters.
- Pin A1's location may be indicated by an ID dot in its proximity on the package surface.

Tables 15–11 and 15–12 show package information for the 672-pin thermally enhanced package.

Description	Specification
Ordering code reference	F
Package acronym	FineLine BGA
Substrate material	BT
Solder ball composition	Register: 63Sn: 37Pb (typical) Pb-free: Sn: 3.0Ag: 0.5Cu (typical)
JEDEC outline reference	MS-034 variation AAL-1
Maximum lead coplanarity	0.008 inches (0.20 mm)
Weight	7.7 g
Moisture sensitivity level	Printed on moisture barrier bag

Symbol	Dimensions (mm)		
	Min.	Nom.	Max.
A	–	–	2.60
A1	0.30	–	–
A2	–	–	2.30
A3	–	–	1.80
D	27.00 BSC		
E	27.00 BSC		
b	0.50	0.60	0.70
e	1.00 BSC		

Figure 15–5 shows a package outline for the 672-pin thermally enhanced package.

Figure 15–5. Package Outline for 672-Pin Thermally Enhanced Package

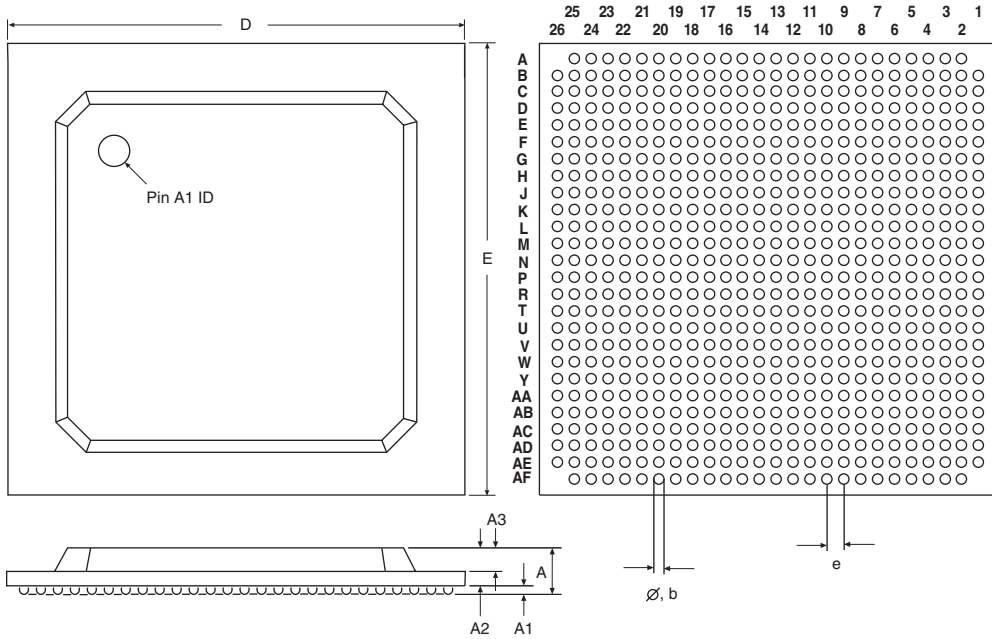

896-Pin Thermally Enhanced FineLine BGA Package

- All dimensions and tolerances conform to ASME Y14.5M - 1994.
- Controlling dimension is in millimeters.
- Pin A1's location may be indicated by an ID dot in its proximity on the package surface.

Tables 15–13 and 15–14 show package information for the 896-pin thermally enhanced package.

Table 15–13. Package Information	
Description	Specification
Ordering code reference	F
Package acronym	FineLine BGA
Substrate material	BT
Solder ball composition	Regular: 63Sn: 37Pb (typical) Pb-free: Sn: 3.0Ag: 0.5Cu (typical)
JEDEC outline reference	MS-034 variation AAP-1
Maximum lead coplanarity	0.008 inches (0.20 mm)
Weight	11.5 g
Moisture sensitivity level	Printed on moisture barrier bag

Table 15–14. Package Outline Figure References			
Symbol	Dimensions (mm)		
	Min.	Nom.	Max.
A	–	–	2.60
A1	0.30	–	–
A2	–	–	2.30
A3	–	–	1.80
D	31.00 BSC		
E	31.00 BSC		
b	0.50	0.60	0.70
e	1.00 BSC		

Figure 15–6 shows a package outline for the 896-pin thermally enhanced package.

Figure 15–6. Package Outline for 896-Pin Thermally Enhanced Package

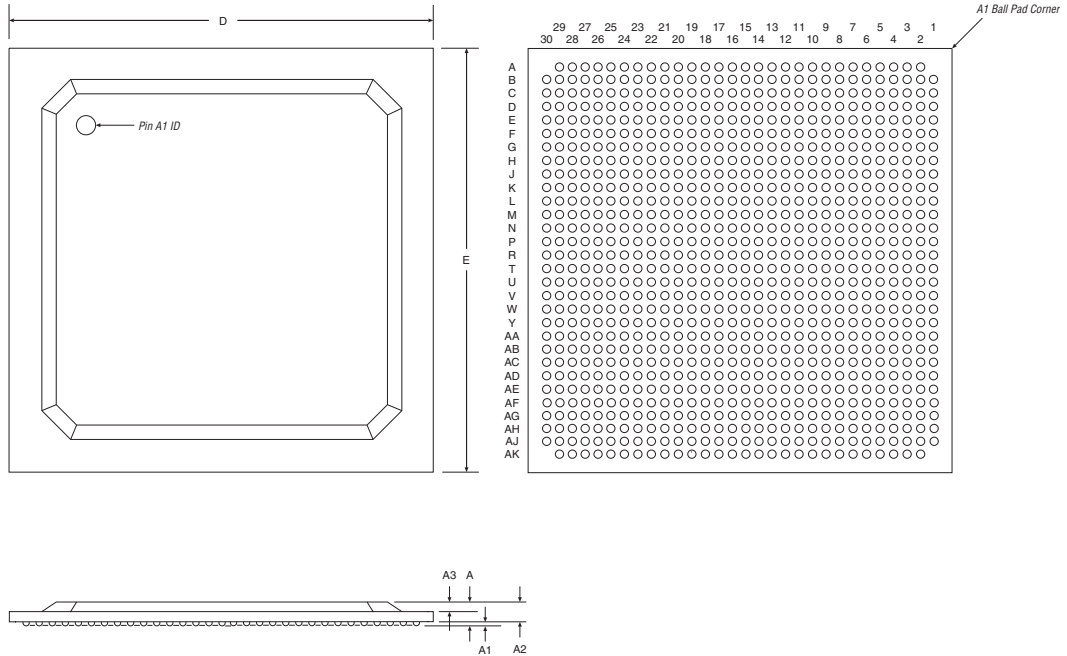

Results For: EP2C70*

6 part numbers found and 0 obsolete part numbers found

Cyclone II Device Family

[Cyclone II Datasheet](#)
[Part Number Format](#)

[Cyclone II Literature](#)
[Buying Altera Devices](#)

Part Number	Device	Pin & Package	Temperature	Speeds	Options
EP2C70F672C6 EP2C70F672C7 EP2C70F672C8	EP2C70	672 pin FBGA	Commercial (0 to 85°C)	6, 7, 8	None
EP2C70F896C6 EP2C70F896C7 EP2C70F896C8	EP2C70	896 pin FBGA	Commercial (0 to 85°C)	6, 7, 8	None

[Advanced](#) [Help](#)

[Please Give Us Feedback](#)
[Sign Up for E-mail Updates](#)

Results For: EP2C8*

9 part numbers found and 0 obsolete part numbers found

Cyclone II Device Family

[Cyclone II Datasheet](#)
[Part Number Format](#)

[Cyclone II Literature](#)
[Buying Altera Devices](#)

Part Number	Device	Pin & Package	Temperature	Speeds	Options
EP2C8F256C6 EP2C8F256C7 EP2C8F256C8	EP2C8	256 pin FBGA	Commercial (0 to 85°C)	6, 7, 8	None
EP2C8Q208C6 EP2C8Q208C7 EP2C8Q208C8	EP2C8	208 pin PQFP	Commercial (0 to 85°C)	6, 7, 8	None
EP2C8T144C6 EP2C8T144C7 EP2C8T144C8	EP2C8	144 pin TQFP	Commercial (0 to 85°C)	6, 7, 8	None

[Advanced](#) [Help](#)

[Please Give Us Feedback](#)
[Sign Up for E-mail Updates](#)

Results For: EP2C20*

9 part numbers found and 0 obsolete part numbers found

Cyclone II Device Family

[Cyclone II Datasheet](#)
[Part Number Format](#)

[Cyclone II Literature](#)
[Buying Altera Devices](#)

Part Number	Device	Pin & Package	Temperature	Speeds	Options
EP2C20F256C6 EP2C20F256C7 EP2C20F256C8	EP2C20	256 pin FBGA	Commercial (0 to 85°C)	6, 7, 8	None
EP2C20F484C6 EP2C20F484C7 EP2C20F484C8	EP2C20	484 pin FBGA	Commercial (0 to 85°C)	6, 7, 8	None
EP2C20Q208C6 EP2C20Q208C7 EP2C20Q208C8	EP2C20	208 pin PQFP	Commercial (0 to 85°C)	6, 7, 8	None

[Advanced](#) [Help](#)

[Please Give Us Feedback](#)
[Sign Up for E-mail Updates](#)

Results For: EP2C5*

15 part numbers found and 0 obsolete part numbers found

Cyclone II Device Family					
Cyclone II Datasheet			Cyclone II Literature		
Part Number Format			Buying Altera Devices		
Part Number	Device	Pin & Package	Temperature	Speeds	Options
EP2C5F256C6 EP2C5F256C7 EP2C5F256C8	EP2C5	256 pin FBGA	Commercial (0 to 85°C)	6, 7, 8	None
EP2C5Q208C6 EP2C5Q208C7 EP2C5Q208C8	EP2C5	208 pin PQFP	Commercial (0 to 85°C)	6, 7, 8	None
EP2C5T144C6 EP2C5T144C7 EP2C5T144C8	EP2C5	144 pin TQFP	Commercial (0 to 85°C)	6, 7, 8	None
EP2C50F484C6 EP2C50F484C7 EP2C50F484C8	EP2C50	484 pin FBGA	Commercial (0 to 85°C)	6, 7, 8	None
EP2C50F672C6 EP2C50F672C7 EP2C50F672C8	EP2C50	672 pin FBGA	Commercial (0 to 85°C)	6, 7, 8	None

[Advanced](#) [Help](#)

[Please Give Us Feedback](#)
[Sign Up for E-mail Updates](#)

Results For: EP2C35*

6 part numbers found and 0 obsolete part numbers found

Cyclone II Device Family					
Cyclone II Datasheet Part Number Format			Cyclone II Literature Buying Altera Devices		
Part Number	Device	Pin & Package	Temperature	Speeds	Options
EP2C35F484C6 EP2C35F484C7 EP2C35F484C8	EP2C35	484 pin FBGA	Commercial (0 to 85°C)	6, 7, 8	None
EP2C35F672C6 EP2C35F672C7 EP2C35F672C8	EP2C35	672 pin FBGA	Commercial (0 to 85°C)	6, 7, 8	None

[Advanced](#) [Help](#)

[Please Give Us Feedback](#)
[Sign Up for E-mail Updates](#)

Choose Your Device

- [FPGA vs ASIC Calculator](#)
- [Device Family Overview](#)
- [Performance Advantages](#)

FPGAs

- [Stratix II](#)
- [Stratix](#)
- [Cyclone II](#)
- [Cyclone](#)
- [Stratix II GX](#)
- [Stratix GX](#)
- [APEX II](#)
- [APEX 20K](#)
- [Mercury](#)
- [FLEX 10K](#)
- [ACEX 1K](#)
- [FLEX 6000](#)

CPLDs

- [MAX II](#)
- [MAX 3000A](#)
- [MAX 7000](#)

Structured ASICs

- [About HardCopy](#)
- [HardCopy II](#)

[Home](#) > [Products](#) > [Devices](#) > Extended Temperature

[Print This Page](#)
 [E-mail This Page](#)

Extended Temperature Device Support

Altera's extended temperature product offerings allow designers to use FPGAs and CPLDs in high-temperature environments such as automotive telematics, infotainment, and driver assistance systems, as well as temperature-sensitive military and industrial applications.

As automotive electronics continue to rapidly add more functionality and features, Altera's FPGAs and CPLDs offer many benefits over ASSP or ASIC solutions. These benefits include lower overall development costs, shorter development times and the ability to leverage a single chip solution over a wide range of product offerings.

Table 1 shows the temperature ranges for Altera[®] devices.

<i>Table 1. Altera Device Temperature Ranges</i>	
Altera Device Type	Extended Junction Temperature
MAX [®] 7000AE	-40°C to 130°C
MAX II/G	-40°C to 125°C
Cyclone [™] , Cyclone II, ACEX [®] 1K	-40°C to 125°C
Serial, Enhanced Configuration Devices	-40°C to 125°C

Product Families Supported

- [HardCopy Stratix](#)
- [HardCopy APEX 20K](#)

- Configuration Devices
- [Enhanced Configuration](#)
 - [Serial Configuration](#)

- Embedded Processors
- [About Excalibur](#)
 - [Excalibur Devices](#)

- Market-Specific Offerings
- [Lead-Free Extended Temperature Industrial Military](#)

- Mature Devices
- [FLEX 8000](#)
 - [MAX 9000 Classic](#)

Tables 2 through 8 show which Altera device voltages offer extended temperature support.

Table 2. Cyclone II FPGA Extended Temperature Offerings (1)					
Device	Package	Operational Speed Grade	Ordering Part Number	Supply Voltage	5.0 V I/O Compatible
EP2C5	T144	-8	EP2C5T144I8	1.2 V	No
	Q208		EP2C5Q208I8		
	F256		EP2C5F256I8		
EP2C8	T144	-8	EP2C8T144I8	1.2 V	No
	Q208		EP2C8Q208I8		
	F256		EP2C8F256I8		
EP2C20	F256	-8	EP2C20F256I8	1.2 V	No
	F484		EP2C20F484I8		
EP2C35	U484	-8	EP2C35U484I8	1.2 V	No
	F484		EP2C35F484I8		
	F672		EP2C35F672I8		
EP2C50	U484	-8	EP2C50U484I8	1.2 V	No
	F484		EP2C50F484I8		
	F672		EP2C50F672I8		
EP2C70	F672	-8	EP2C70F672I8	1.2V	No
	F896		EP2C70F896I8		

Note to Table 2:

1. For more details, please refer to the [Extended Temperature Support for Cyclone II & MAX II Devices](#) white paper (PDF).

Table 3. MAX II CPLD Extended Temperature Offerings (1)					
Device	Package	Operational Speed Grade	Ordering Part Number	Supply Voltage	5.0 V I/O Compatible
EPM240	T100	-5	EPM240T100I5	3.3 V, 2.5 V	No

EPM570	T100 T144 F256	-5	EPM570T100I5 EPM570T144I5 EPM570F256I5	3.3 V, 2.5 V	No
EPM1270	T144 F256	-5	EPM1270T144I5 EPM1270F256I5	3.3 V, 2.5 V	Yes (2)
EPM2210	F256 F324	-5	EPM2210F256I5 EPM2210F324I5	3.3 V, 2.5 V	Yes (2)

Note to Table 3:

1. For more details, please refer to the [Extended Temperature Support for Cyclone II & MAX II Devices](#) white paper (PDF).
2. EPM1270 and EPM2210 are 5-V tolerant when used with an external series resistor.

Table 4. MAX IIG CPLD Extended Temperature Offerings (1)					
Device	Package	Operational Speed Grade	Ordering Part Number	Supply Voltage	5.0 V I/O Compatible
EPM240G	T100	-5	EPM240GT100I5	1.8V	No
EPM570G	T100 T144 F256	-5	EPM570GT100I5 EPM570GT144I5 EPM570GF256I5	1.8V	No
EPM1270G	T144 F256	-5	EPM1270GT144I5 EPM1270GF256I5	1.8V	Yes (2)
EPM2210G	F256 F324	-5	EPM2210GF256I5 EPM2210GF324I5	1.8V	Yes (2)

Note to Table 4:

1. For more details, please refer to the [Extended Temperature Support for Cyclone II & MAX II Devices](#) white paper (PDF).
2. EPM1270G and EPM2210G are 5-V tolerant when used with an external series resistor.

[Please Give Us Feedback](#)
[Sign Up for E-mail Updates](#)



Table 5. MAX 7000AE CPLD Extended Temperature Offerings (1)

Device	Package	Operational Speed Grade	Ordering Part Number	Supply Voltage	5.0 V I/O Compatible
EPM7032AE	T44	-10	EPM7032AETI44-7	3.3 V	Yes
EPM7064AE	T44 T100	-10 -10	EPM7064AETI44-7 EPM7064AETI100-7	3.3 V	Yes
EPM7128AE	T100 T144	-10 -10	EPM7128AETI100-7 EPM7128AETI144-7	3.3 V	Yes
EPM7256AE	T144 F256	-10 -10	EPM7256AETI144-7 EPM7256AEFI256-7	3.3 V	Yes

Note to Table 5:

1. For more details, please refer to the [Extended Temperature Support for MAX 7000AE, Cyclone, Stratix & ACEX 1K Devices](#) white paper (PDF).

Table 6. Cyclone FPGA Extended Temperature Offerings (1)

Device	Package	Operational Speed Grade	Ordering Part Number	Supply Voltage	5.0 V I/O Compatible
EP1C3	T144	-8	EP1C3T144I7	1.5 V	No
EP1C4	F324	-8	EP1C4F324I7	1.5 V	No
EP1C6	T144 F256	-8 -8	EP1C6T144I7 EP1C6F256I7	1.5 V	No
EP1C12	F256 F324	-8 -8	EP1C12F256I7 EP1C12F324I7	1.5 V	No
EP1C20	F400	-8	EP1C20F400I7	1.5 V	No

Note to Table 6:

1. For more details, please refer to the [Extended Temperature Support for MAX 7000AE, Cyclone, Stratix & ACEX 1K Devices](#) white paper (PDF).

Device	Package	Operational Speed Grade	Ordering Part Number	Supply Voltage	5.0 V I/O Compatible
EP1K10	T100	-3	EP1K10TI100-2	2.5 V	Yes
EP1K30	T144	-3	EP1K30TI144-2	2.5 V	Yes
EP1K50	Q208	-3	EP1K50QI208-2	2.5 V	Yes
	F256	-3	EP1K50FI256-2		
EP1K100	Q208	-3	EP1K100QI208-2	2.5 V	Yes
	F256	-3	EP1K100FI256-2		

Note to Table 7:

1. For more details, please refer to the [Extended Temperature Support for MAX 7000AE, Cyclone, Stratix & ACEX 1K Devices](#) white paper (PDF).

Device	Package	Ordering Part Number	Supply Voltage
EPC1	L20	EPC1LI20	3.3 V
EPC2	L20	EPC2LI20	3.3 V
EPCS1	S8	EPCS1SI8	3.3 V
EPCS4	S8	EPCS4SI8	3.3 V
EPCS16	S16	EPCS16SI16N	3.3 V
EPCS64	S16	EPCS64SI16N	3.3 V

Related Links

- [Extended Temperature Support for Cyclone II & MAX II Devices](#) white paper (PDF)
- [Extended Temperature Support for MAX 7000AE, Cyclone, Stratix & ACEX 1K Devices](#) white paper (PDF)
- [Automotive End Market](#)

- [Automotive Market Requirements](#)
- [Extended Temperature Questions & Answers](#)
- [Extended Temperature Support for Cyclone Devices](#) white paper (PDF)

[Rate This Page](#)

[Home](#) | [Products](#) | [Support](#) | [End Markets](#) | [Technology Center](#) | [Education & Events](#) | [Corporate](#) | [Buy On-Line Devices](#) | [Design Software](#) | [Intellectual Property](#) | [Design Services](#) | [Dev. Kits/Cables](#) | [Literature](#)

[Contact Us](#) | [Site Help](#) | [Site Map](#) | [Privacy](#) | [Legal Notice](#)

Copyright © 1995-2006 Altera Corporation, 101 Innovation Drive, San Jose, California 95134, USA